

杰克缝纫机
全球销量遥遥领先
Leading in global sales

400-8876-858
www.chinajack.com



JACK SEWING MACHINE CO., LTD.

2017年08月 第1版 2017

杰克缝纫机股份有限公司
浙江嘉善经济开发区嘉善大道111号
电话: 0573-82011111 82011111
传真: 0573-82011111
电子邮箱: 42748871@163.com
www.chinajack.com

JACK SEWING MACHINE CO., LTD.
No. 111, Jiaqian Road, Jiaxing Economic Development Zone, Jiaxing, Zhejiang, P.R.C.
Tel: 0573-82011111 82011111 E-mail: sales@chinajack.com
Fax: 0573-82011111 www.chinajack.com
© 2017 Jack Sewing Machine Co., Ltd.
This manual is copyrighted by Jack Sewing Machine Co., Ltd. All rights reserved.



JK-T781E
产品使用说明书
Manual book

JACK 杰克

警告：为了您的人身安全，使用该产品时，电源插头的地线必须接地，一定要做好系统的接地工程，否则可能触电！

Warning: For your personal safety, when operating the kind of products, please make sure that the ground wire of power plug is connected to ground, otherwise an electric shock may occur.



安全指示 Safety Instruction:

1. 在安装或使用本产品前，请务必仔细阅读本使用说明书，并将本使用说明书妥善保管，以备随时查阅。

Users are required to read the operation manual completely and carefully before installation or operation and keep it properly for reference at any time.

2. 所有标上△符号的指示，必须特别注意或执行，否则可能会导致人身伤害或设备损坏。
All the instruction marked with sign △ must be special observed or executed; otherwise, bodily injuries or damaged equipment might occur.

3. 本产品须由受过正确训练的人员来安装或操作。

The product should be installed and pre-operated by well trained persons.

4. 为安全起见，禁止以延长线作电源座供应二项以上的电器产品使用。

For perfect operation and safety, it is prohibited that using extension cable with multi-outlet for power connection.

5. 当连接电源线到电源座时，必须确定此电压低于 AC 250V，且符合标在马达铭牌上的指定电压。

When connecting power supply cords to power sources, it is necessary to make sure that the power voltage is lower than 250 VAC and matches the rated voltage indicated on the motor's nameplate.

※注意：电控箱电源规格如为 AC220V 时，请勿插接至 AC380V 的电源插座上，否则将出现异常且电机将无法动作。此时请立即关闭电源开关，重新检查电源。持续供应 380V 超过五分钟以上，将可能烧损电控箱而危及人身安全。



Attention: If the control box is AC220V system, please don't connect to the AC380V power outlet, otherwise the error will occur and motor will not work. If that happened, turn off the power switch immediately and re-check the power. Continue supply 380V power over 5 minutes might burst the electrolytic capacitors and even endanger the person safety.

1. 请在环境温度 5℃~45℃ 的范围内，并且无日光直接照射的场所使用。

Please avoid operating in direct sun light or at the ambient temperature below 5% or above 45%.

2. 请在相对湿度 30%~95% 的范围内，并且设备内不会行成结露的场所使用。

Please avoid operating at dew area or at the humidity below 30% or above 95%.

3. 请在灰尘少，并且没有腐蚀性物质、可燃气体的场所使用。
Don't operate in area with heavy dust, corrosive substance or volatile gas.
4. 请注意电源线不要受压或过度扭曲。
Avoid power cord being applied by heavy objects or excessive force, or over bend.
5. 电源线的接地线须以适当的导线和接头连接到生产工厂的系统地线，此连接必须固定。
The earth wire of power cord must be connected to the system ground of the production plant by proper size of conductions and terminals. This connection should be fixed.
6. 所有可转动的部分，必须以所提供的零件加以防范露出。
All the moving portions must be prevented to be exposed by the parts provided.
7. 在第一次开机使用时，先以低速操作缝纫机并检查转动方向是否正确。
When turn on the machine in the first time, operate the sewing machine at low speed and check the correct rotation direction.
8. 发生下列情况时，请先关闭电源：
Turn off the power before the following situation：
 - 1) 在电控或马达上插拔任何连接器和接线时。
Connecting or disconnecting any connectors on the control box or motor.
 - 2) 机针穿线时。
Threading needle.
 - 3) 翻抬车头时。
Raising the machine head.
 - 4) 进行任何机械上的调整时。
Doing any mechanical adjustment
 - 5) 不使用或无人看管机器时。
Machines idling or unattended machine.
9. 只有受过培训的专业技术人员才能进行本产品的维修、保养和检查。
Repairs、maintenance work and checks should only be carried out by with professionals appropriate training.
10. 所有维修用的零件，须由本公司提供认可，方可使用。
All the spare parts for repair must be provided or approved by the manufacturer.
11. 请不要以不适当物体来敲打或撞击本产品及各装置。
Do not use any objects to beat or impact the products and devices.

保修期限

Guarantee Time

本产品保修期限为购买日期起一年内或出厂日期起两年内。

Warranty period of this product is 1 year dated from purchasing, or within 2 years from ex-factory date.

保修内容

Warranty Detail

本产品在正常情况且无人为失误的操作下，于保修期间无偿的为客户维修使能正常操作。

Any trouble found within warranty period under normal operation, it will be repaired free of charge. However, maintenance cost will be charged in the following cases even if within warranty period:

但以下情况于保修期间将收取维修费用：

will be charged in the following cases even if within warranty period:

- 1、意外因素或人为因素所导致的产品故障或损坏，如输入不适合电压、将产品移做其它用途、自行拆装修理、进水、进油、机械破坏、摔坏等。

Product failure or damage caused by unexpected factors or human factors, such as wrong connecting high voltage, wrong application, disassemble, repair, modification by incompetent personnel, liquids、oils into the product, physical disturbance or broken.

- 2、因不可抗力力导致的产品故障或损坏，如地震、雷击、火灾、水灾、盐蚀、潮湿等。

Product failure or damage is caused by force majeure factors, such as earth quake, lighting, fire, flood, salt corrosive, moisture.

- 3、客户购买后，自行运输或托付运输公司运输过程中导致的产品故障或损坏。

Product failure or damage in transportation by customer himself or by customer's shipping agency after purchasing.

- 4、其他非产品本身设计、技术、制造、质量等问题导致的产品故障或损坏。

Product failure or damaged is not caused by itself, such as design, technology, manufacture, quality.

* 本产品在整個生产过程中严格控制，使其达到高品质、高稳定的标准，但外部的强电气干扰，仍可能对本产品造成影响或损害，因此操作场所的接地系统一定要切实做好，并建议用户安装故障安全防护装置（如漏电保护器）。

We make our best effort to test and manufacture the product for assuring the quality. However, it is possible that this product can be damaged due to strong external electrical interference; therefore the grounding system of operate area must be well-connected to this product and it's also recommended to install a failsafe device. (such as residual current breaker).

使用说明目录







MANUAL BOOK CONTENTS







1、操作说明	1
INSTRUCTIONS	
2、用户参数&技术员数	7
USER PARAMETER&TECHNICIAN PARAMETER	
3、错误代码表	11
ERROR CODES TABLE	
4、端口示意图	13
PORT SCHEMATIC DIAGRAM	
5、安装说明	14
INSTALLATION INSTRUCTIONS	
6、规格	16
SPECIFICATION	
7、线迹形式	17
TYPES OF STITCHES	
8、缝纫机头的安装	17
SETTING UP THE MACHINE HEAD	
9、梭心的安装方法	17
ATTACHING THE BOBBIN	
10、梭壳的安装方法	18
INSTALLATION/REMOVAL OF BOBBIN CASE	
11、机针的安装方法	18
HOW TO INSTALL THE NEEDLE	
12、线架的安装	18
SETTING UP THE THREAD STAND	
13、加油	19
LUBRICATION	
14、底线的绕线方法	19
WINDING THE BOBBON	
15、上线的穿线方法	20
THREAD THE NEEDLE-THREAD	
16、手动送布手柄	20
MANUAL FEED HANDLE	
17、防止切刀掉落	20
HOW TO HOLD THE DESCENDING KNIFE	
18、针数的变换方法	21
CHANGING THE NUMBER OF STITCHES	
19、机针和旋梭的关系	22
NEEDLE-TO-HOOK RELATION	

20、线张力·····	23
THREAD TENSION	
21、缝边长度(送布量)的调节·····	24
ADJUSTING THE OVEREDGING LENGTH(BUTTONHOLE LENGTH)	
22、锁眼宽度以及缝锁基准位置的调节·····	24
ADJUSTING THE OVEREDGING WIDTH AND OVEREDGING REFERENCE POSION	
23、压脚的压力调整·····	25
ADJUSTING THE PRESSER BAR PRESSURE	
24、切刀的更换·····	25
REPLACING THE KNIFE	
25、上线切线的调整·····	26
ADJUSTMENT OF THE NEEDLE THREAD TRIMMER	
26、上线切线动作曲轴和限制板的调整·····	27
ADJUSTMENT OF NEEDLE THREAD TRIMMER HOLDER AND LIMITING PLATE	
27、切刀落刀时期的调整·····	27
TIMING FOR DROPPING THE KNIFE	
28、有关缝制的故障、原因及处理方法·····	28
TROUBLE, CAUSE, AND REMEDY	

1: 操作说明 INSTRUCTION

1.1: 按键说明 KEY DESCRIPTION

<p>1、进入和确定存储内容值 2、锁定、触发功能</p>		<p>1、进入参数内容值，其内容值如经调整变更后，需按下  键予以储存确认。 2、正常界面，按下该键时显示面板出现无运转、压脚下放处于锁定模式，踩踏无效，反踏压脚抬起；再次按下该键恢复到正常界面，踏板踩踏正常。</p>
<p>进入参数区功能键</p>		<p>1.一般开机模式下按  键进入用户参数模式 2.按住  键开机进入技术员参数模式</p>
<p>设置数值递增/参数递增</p>		<p>1、参数选择区内当参数递增键。 2、参数内容区内当设定数值递增键。</p>
<p>设置数值递减/参数递减</p>		<p>1、参数选择区内当参数递减键。 2、参数内容区内当设定数值递减键。</p>

<p>1、Enter and save the value 2、lock, start function</p>		<p>1、Enter to the parameter value, press  key for confirmation and save if the parameter value adjustment. 2、Normal interface, display panel appears when you press the button without running, under the presser foot put in lockdown mode, stampede invalid, anti-riding presser foot lift; press the key again to return to normal screen, pedal stampede normal.</p>
<p>Enter parameter value selection</p>		<p>1. In 1Normal Mode, press  key to enter User Parameter Mode1. 2. Press and hold  key, then turn on the power to enter Technician Parameter Mode.</p>
<p>Value Increment Key</p>		<p>1、Increase the parameter in Parameter selection. 2、Increase the setting value in Parameter value.</p>
<p>Value Decrement Key</p>		<p>1、Decrease the parameter in Parameter selection. 2、Decrease the setting value in Parameter value.</p>

1.2 操作OPERATIONAL

1.2.1 恢复出厂设置RESTORE THE FACTORY SETTING

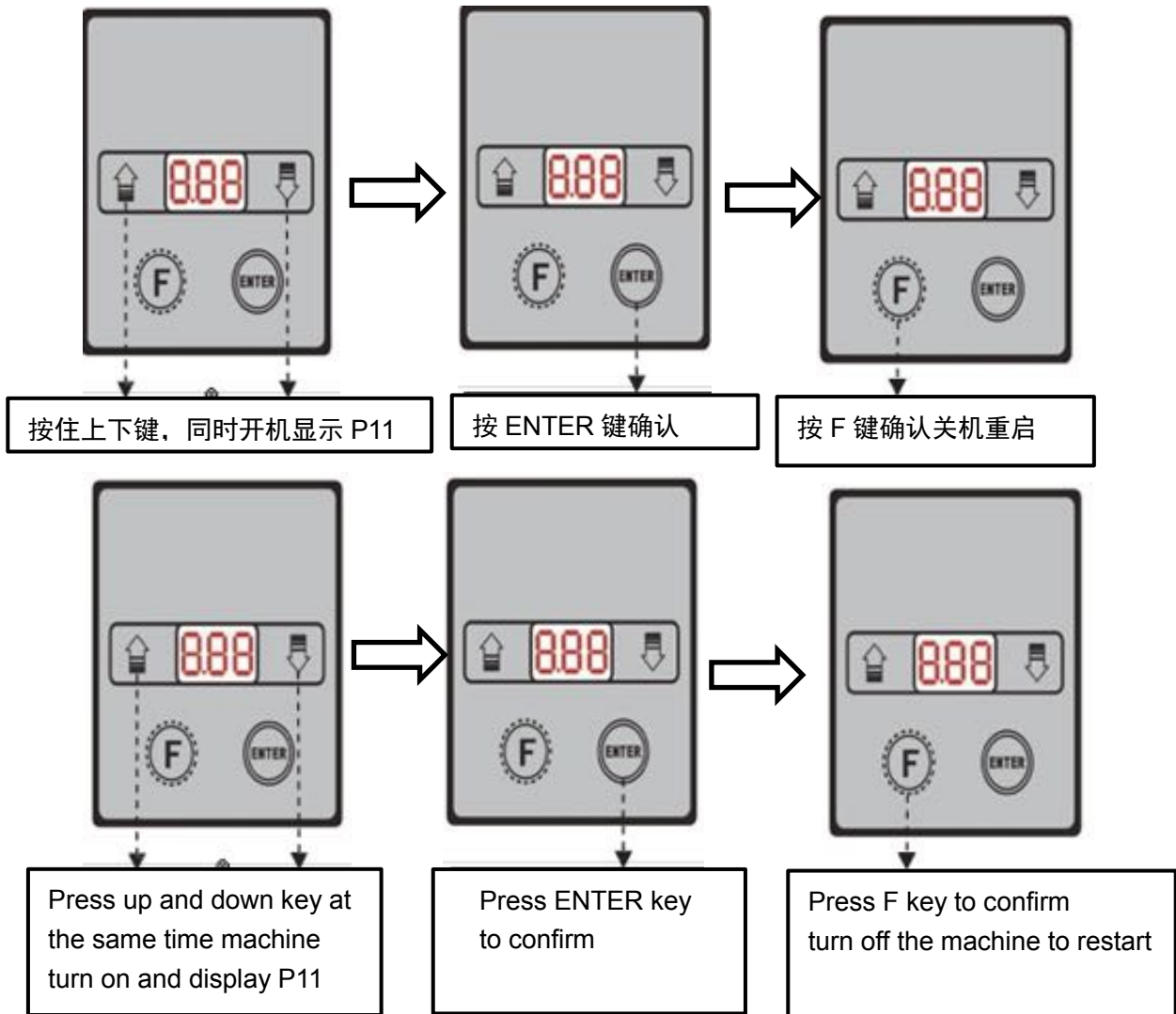

1.2.2: 进入用户模式及修改保存 ENTER THE USER MODE TO MODIFY AND SAVE THE PARAMETER

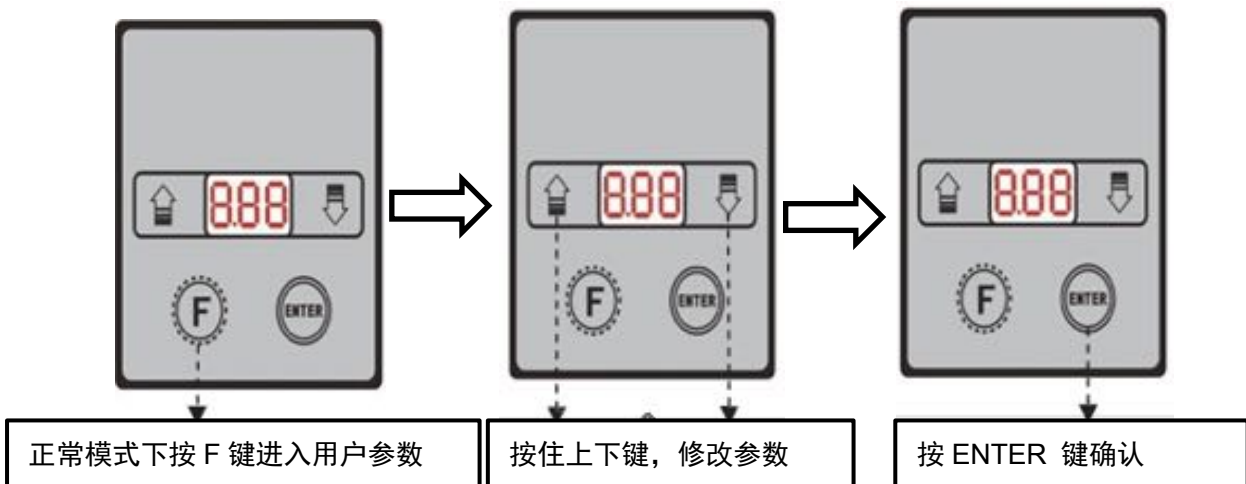

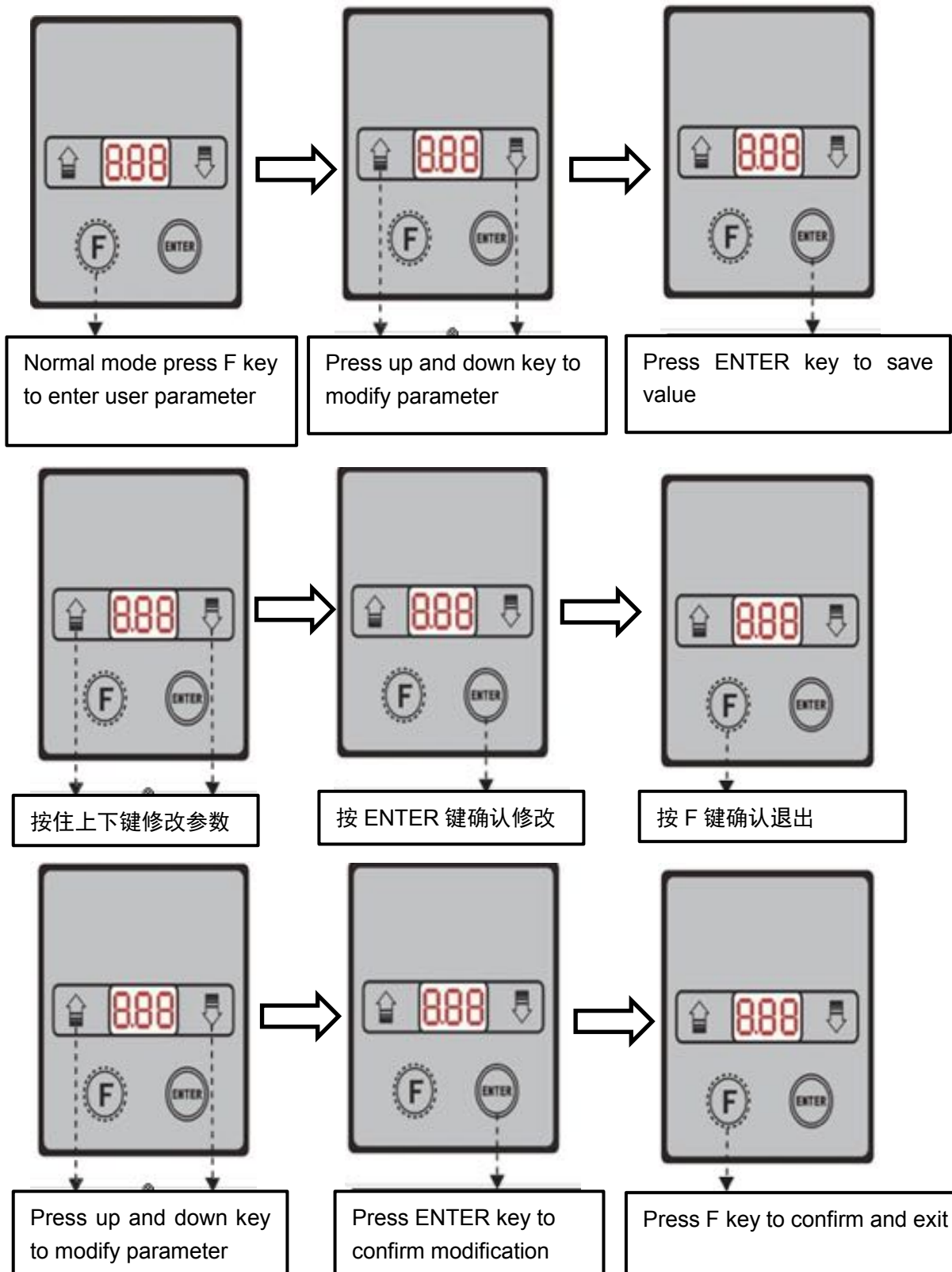

1.2.3: 进入技术员模式及修改保存 ENTER THE TECHNICIAN MODE TO MODIFY AND SAVE THE PARAMETER

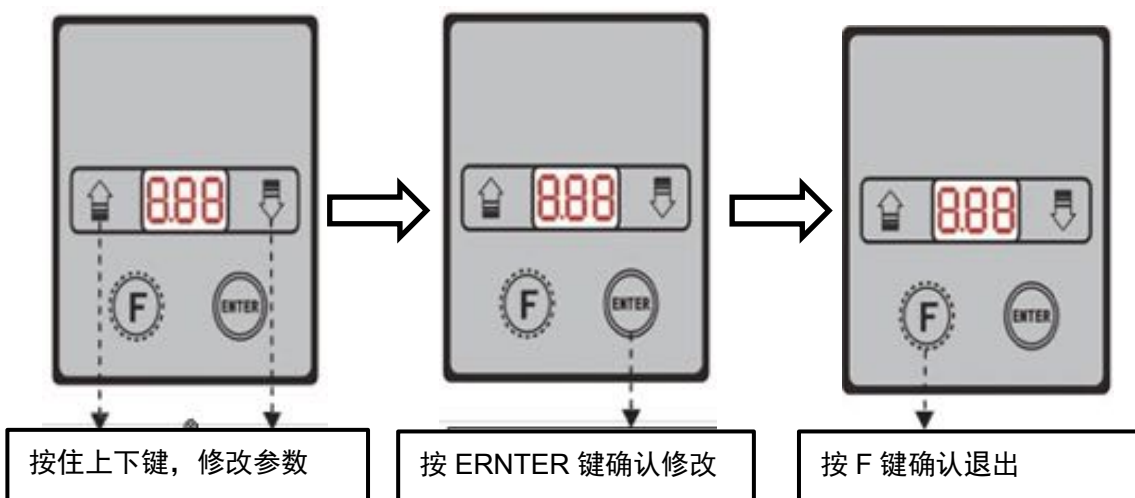
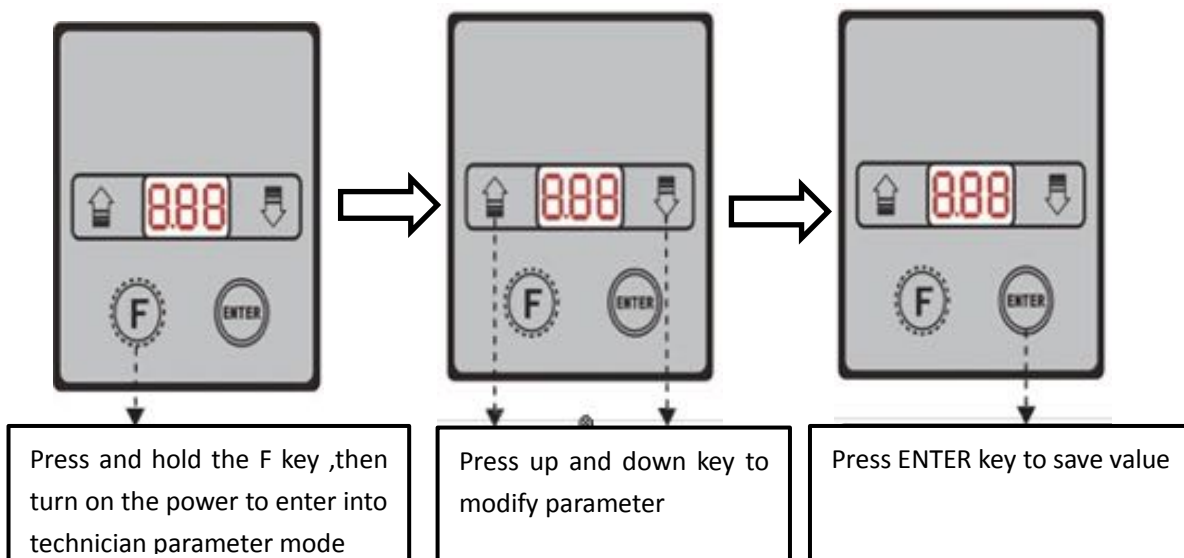
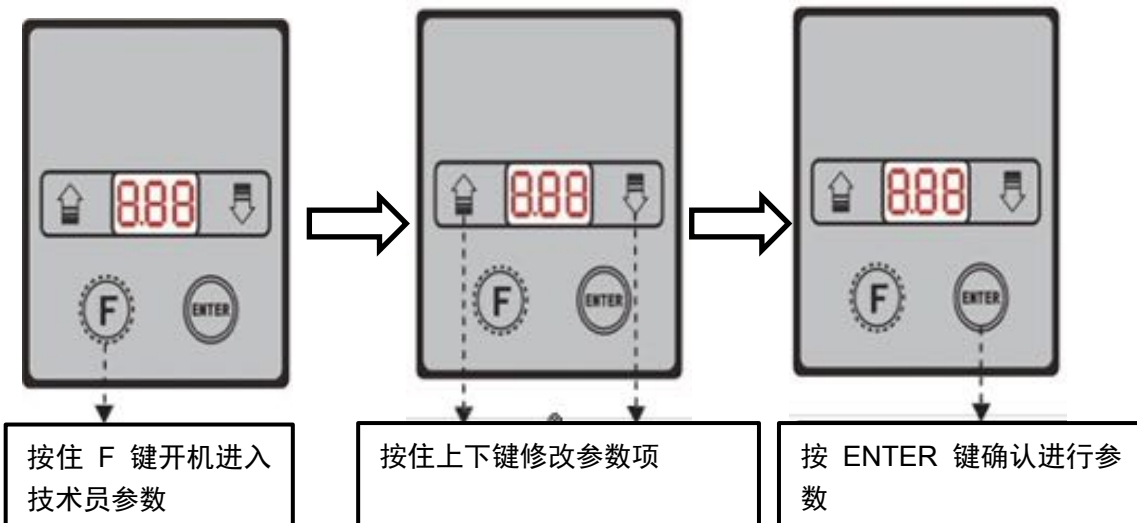

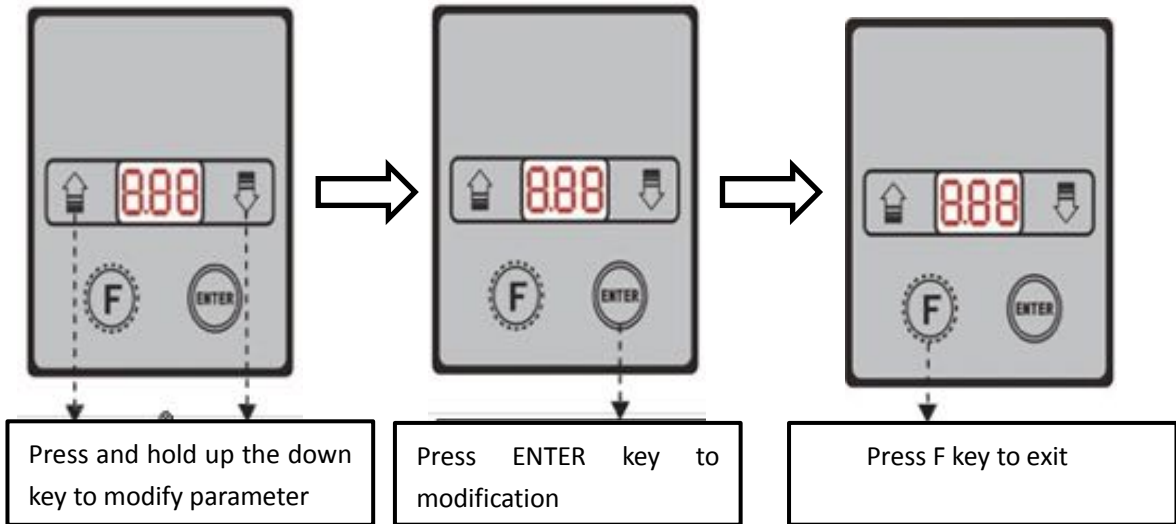

1.3: 数码款操作说明 THE INSTRUCTION OF DIGITAL TYPE

1.3.1 液晶显示字体与实际字体对照表 LCD FONTS AND THE ACTUAL FONTS COMPARISION TABLE

数字字体部分: Arabic Numerals

实际数值 Actual number	0	1	2	3	4	5	6	7	8	9
液晶显示 LCD Display	0	1	2	3	4	5	6	7	8	9

1.3.2 液晶画面的显示模式 THE LCD DISPLAY MODE

英文字体部分: English Alphabet

英文字母 Actual	A	B	C	D	E	F	G	H	I	J
液晶显示 Display	A	b	C	d	E	F	G	H	i	J
英文字母 Actual	K	L	M	N	O	P	Q	R	S	T
液晶显示 Display	t	L	n	n	o	P	q	r	S	r
英文字母 Actual	U	V	W	X	Y	Z				
液晶显示 Display	U	v	8	11	P	≡				

1.4 针数变换说明 NEEDLE NUMBER CHANG

1.4.1 针数齿轮与 P10 参数对照表:NEEDLE NUMBER GEAR AND P10 PARAMETER COMPARISON TABLE

针数 Needle Number	83	100	110	123	152	170	19	225
P10 参数 Parameter	3	3	4	5	5	6	7	8

1.4.2 针数变化及开机说明: NEEDLE NUMBER CHANGE AND INSTRUCTION



每次开机或者更换针数齿轮后，程序需要确认当前花样的针数，因此在开机或者更换针数齿轮后，缝制前两个锁眼是程序来确定当前花样实际针数的，请不要踩暂停，以免针数计算错误，出现停针位置不对或者切刀不返回现象。

Each time after start or replace gear, and the program needs to confirm the current pattern of needle number, so after start or replace needle number gear, first two keyhole is confirmed by the current pattern of the actual pin number, please don't stop in order to avoid wrong calculate or wrong needle position



2: 用户参数&技术员参数: USER PARAMETER & TECHNICIAN PARAMETER







2.1:用户参数 USER PARAMETER

参数项 Parameter	中文说明 Instruction	范围 Range/ unit	初始值 Default	设定键 Key	内容值名称说明与备注 Description
P01	最高转速 (spm) Maximum rotating Speed (spm)	10~360	300		车缝时的最高转速设定 (实际速度=显示数*10) Maximum rotating speed of machine sewing (the actual speed = display * 10))
P02	起缝速度 (spm) sewing speed (spm)	20~360	130		前缝 (起缝) 时的速度设定 (实际速度=显示数*10) speed of machine sewing (start sewing) (actual speed = display * 10))
P03	切刀动作速度 Cutter moving speed	10- 100	55		切刀时机头的转速 (实际速度=显示数*10) rotating speed of machine head when cutting (actual speed = display * 10))
P04	第一针限速 The first needle limited speed	10~360	80		(实际速度=显示数*10) (actual speed = display * 10))
P05	第二针限速 The second needle limited speed	10~360	80		(实际速度=显示数*10) (actual speed = display * 10))
P06	第三针限速 The third needle limited speed	10~360	200		(实际速度=显示数*10) (actual speed = display * 10))
P07	第四针限速 The fourth needle limited speed	10~360	250		(实际速度=显示数*10) (actual speed = display * 10))

参数项 Parameter	中文说明 Instruction	范围 Range/ unit	初始值 Default	设定键 Key	内容值名称说明与备注 Description
P08	第五针限速（预留） The fifth needle limited speed (Reserve)	10~360	200		(实际速度=显示数*10) (actual speed = display * 10)
P09	压脚保护时间 (s) Presser foot Protection time (s)	1 - 120	8		自动压脚连续抬起超过设置时间自动落下（机械锁） It will automatic come down when foot lifter keep lift over the setting time. ((mechanical lock)
P10	切刀动作针数 Cutter moving speed	0 - 6	3		切刀时所需的针数，配合切刀的速度 Required number of needles coordinating with the cutter speed.

2.2:技术员参数 TECHNICIAN PARAMETER

参数项 Parameter	中文说明 Instruction	范围 Range/ unit	初始值 Default	设定键 Key	内容值名称说明与备注 Description
P16	保护针数 Protected stitches	1 - 990	400		在大盘未感应到情况下，机针要动作多少针进行保护 Required protected machine stitches if crank set have no induction
P17	开机自动找上定位 Needles going up at power on	0 - 1	1		1: 开启电源后，自动找到上定位信号后停止 0: 无作用 1:automatic needle up at power on 0: invalid
P18	上定位调整 Up position adjustment	40 - 180	110		上定位调整，数值减少会提前停针，增加会延迟停针 Up position adjustment, needle up in advance if number decreases needle up delay if number increases

参数项 Parameter	中文说明 Instruction	范围 Range/ unit	初始值 Default	设定键 Key	内容值名称说明与备注 Description
P19	测试工作时间 test working time	1 - 250	20		C 项测试中，设置导通时间 Setting running time of testing C
P20	测试停止时间 test stop time	1 - 250	20		C 项测试中，设置停车时间 Setting stop time of testing C
P21	A 项测试 testing A	0 - 1	0		A 项测试选项，设定后将按 P01 速度进行连续运转测试 Option of Testing A, keep speed P01 to continuous running test after setting press
P22	B 项测试 testing B	0 - 1	0		B 项测试选项，设定后将按 P01 测试速度进行全功能性测试 Option of Testing B, keep speed P01 to functional testing after setting press
P23	C 项测试 testing C	0 - 1	0		C 项测试选项，设定后将按 P01 的速度进行无定位运行 Option of Testing C, keep speed P01 to after setting press
P24	机头保护开关 Machine head Protection Switch	0 - 1	1		0: 无机头保护功能 1: 打开机头保护功能 0: turn off Machine head Protection function 1: turn on Machine head Protection function
P25	机械锁保护开关 Mechanical lock Protection Switch	0 - 1	1		0: 无机械锁保护功能 1: 打机械锁保护功能 0: turn off Mechanical lock Protection function 1: turn on Mechanical lock Protection function

P26	限速项 The speed limit item	100~360	300		限制车缝的最高转速（实际速度=显示数*10） To limit the highest speed sewing, (actual speed = display * 10)
P28	压脚最高位置 Presser foot highest position	0 - 400	250		调整抬压脚最高位置点时步进电机角度 Adjust the angle of the stepper motor position at the highest point of the presser foot lift
P29	压脚中间位置 Presser foot middle position	0 - 400	80		调整抬压脚中间位置点时步进电机角度 Adjust the position point of in the middle presser foot angle stepper motor

3: 错误代码表 ERROR CODES TABLE

错误码 Error Code	内容 Problem	对策 Measures
E1	<p>1) 电力模块错误代码 Power Module is faulty.</p> <p>2) 不正常过电流或过电压 Abnormal over current or voltage.</p>	<p>模块驱动出力与机头出力将全部关闭 The module drive output with head power output will be shutting.</p> <p>等待电源重新开启/复位（请仔细检查电源板各项机能） Waiting for the power board of the each function(Please check the power of each function)</p>
E3	<p>步进电机通讯异常 Stepper motor communication error</p>	<p>检查步进电机驱动板与主控板的通讯线 Check stepper motor driver board and the control board communication lines</p>
E6	<p>步进电机感应未到位或异常 Stepper motors are not in place or abnormal induction</p>	<p>1.检查步进电机的感应器（光电开关）是否异常 Check the stepper motor sensor (photoelectric switch) is abnormal</p> <p>2.步进电机的机械结构是否到位。 Stepper motor mechanical structure is in place.</p>
E7	<p>a)马达插头配线接触不良导致不转 Bad connection at the motor connector.</p> <p>b)定位器信号异常。 Locator signal abnormality.</p> <p>c)车头机构死锁或马达皮带异物卷入卡死。 Machine locked or object stuck in the motor pulley.</p> <p>d)加工物过厚，马达扭力不足无法贯穿。 Sewing material is too thick.</p> <p>e)模块驱动出力异常。 Module output is abnormal.</p>	<p>模块驱动出力与车头出力将全部关闭。 System will be shut down until the power resets on.</p> <p>等待电源重新开启/复位。（请检查车头是否卡住或定位器、马达、模块驱动等信号是否异常） (Please check the machine head connectors, Locators motor and Module output signal is abnormal or not.)</p>
E9	<p>定位器信号异常 Locator signal abnormality.</p>	<p>检查上下定位信号是否正常，皮带轮是否过于松动。 Please check the positioning signal or the condition of pulley.</p>

E11	<p>电源开启即自动找上定位,但定位器有插入控制箱,针上信号无法输出。</p> <p>Power on automatically find [position], but Locators insertion control box, the pin signal is not output.</p>	<p>马达无法正常运行。(请检查定位器是否异常)。</p> <p>The motor stops running. (Please check locator is abnormal).</p>
E12	<p>电源开启时,未插入定位器。</p> <p>At power is turned on, not inserted locator.</p>	<p>自动进入无定位器模式运作,且切线、扫线、上定位等以及所有定针缝式样缝制功能亦无效。</p> <p>马达可正常操作。(请检查定位器是否忘记插入或异常)</p> <p>Motor still can run, but it automatically starts the clutch mode. All constant-stitch sewing pattern and trimmer /wiper function is invalid.(Please check the Locators abnormal or not.)</p>
E13	<p>电力模块过热保护</p> <p>Overheat Protection of Power Module</p>	<p>检查电力模块与散热片是否接触良好。</p> <p>Please check the connection between power module and heat sink.</p>
E14	<p>编码器信号异常</p> <p>Encoder signal error.</p>	<p>检测编码器信号是否正常,或更换编码器。</p> <p>Check if the encoder signals abnormal or change the encoder.</p>
E15	<p>电力模块不正常过流保护</p> <p>Abnormal over current protection for Power Module.</p>	<p>模块驱动出力与机头出力将全部关闭。</p> <p>等待电源重新开启/复位。(请仔细检查电源板各项机能)</p> <p>System will be shut down until the power resets on.</p> <p>Please check the power board in detail.</p>
E17	<p>机头保护开关没到正确位置</p> <p>Machine head switch error.</p>	<p>检查机头是否掀开,机头开关是否损坏。</p> <p>Check if the machine head open or if the machine head switch is damaged.</p>
E18	<p>机械锁保护错误代码</p> <p>Mechanical lock Protection error</p>	<p>检查机械锁位置是否正常,保护开关是否有损坏</p> <p>Check if the Mechanical lock whether abnormal or if the protection switch is damaged.</p>
E19	<p>大盘保护错误代码</p> <p>Broader protection error code</p>	<p>检查大盘位置是否正常,开关是否有损坏</p> <p>Check if the Crank set position whether abnormal or if the switch is damaged.</p>

4 端口示意图 PORT SCHEMATIC DIAGRAM

4.1: 各个端口名称 NAMES OF EACH PORT

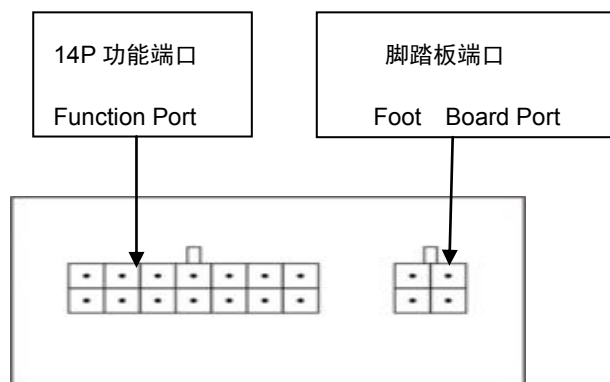

4.2: 14P 功能端口对应表 FUNCTION PORT CORRESPONDING TABLE

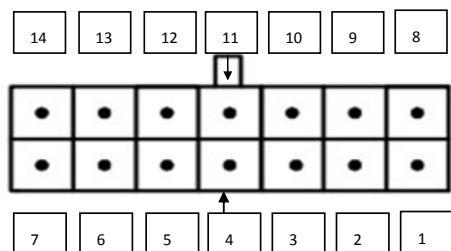

- ① 线电磁铁: 1、8
- ② 衣车灯: 2 (信号地)、9 (+5v)
- ③ 机械锁感应: 5 (信号地)、11 (+5v)、12 (感应信号)
- ④ 大盘结束感应: 3 (感应信号)、4 (信号地)、10 (+5v)
- ⑤ 机械锁电磁铁: 6、13
- ⑥ 抬压脚电磁铁: 7、14

- ① Trimming electromagnet: 1、8
- ② Sewing machine light: 2 (signal ground)、9 (+5v)
- ③ Mechanical lock induction: 5 (signal ground)、11 (+5v)、12 (induced signal)
- ④ End induction of crank set :3 (induced signal)、4 (signal ground)、10 (+5v)
- ⑤ Mechanical lock electromagnet: 6、13
- ⑥ Presser foot electromagnet: 7、14

5: 安装说明 INSTALLATION INSTRUCTIONS

5.1: 控速器踏板拉力的调整 SPEED CONTROL PEDAL PULL ADJUSTMENT



△踏板连接器有加装 VD 吸风系列装置时，建议将 A 与 C 改变安装如右图所示

△In case of connecting with an air switch on the pedal rod to activate a Venturi Device, please shift the position for A and C as shown below.

5.2 : 一体化电控安装操作说明 INTEGRATED ELECTRONIC CONTROL INSTALLATION INSTRUCTIONS

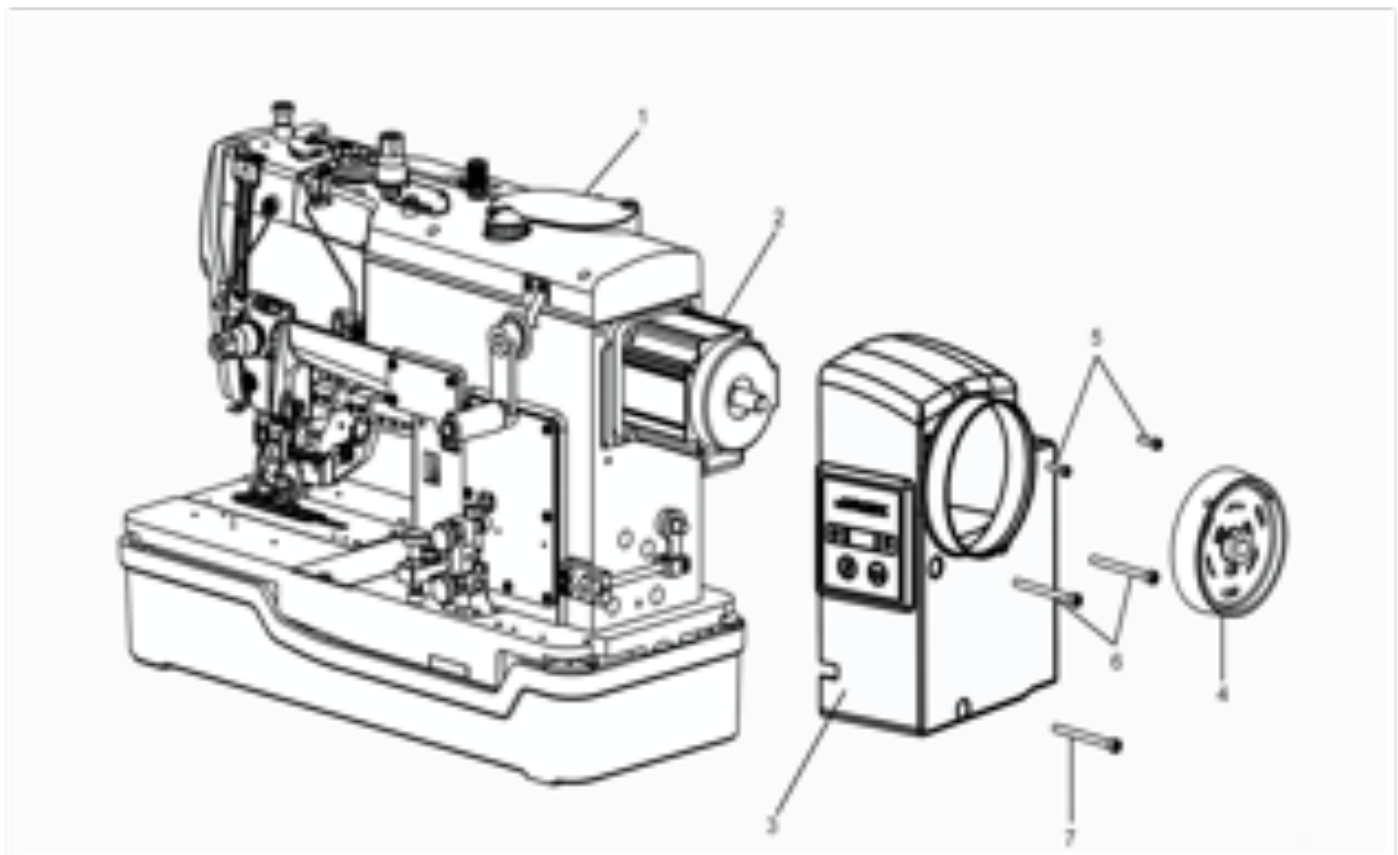

- 1: 机头 Machine Head
- 2: 直驱电机 Direct-motor
- 3: 电控 electronic control
- 4: 手轮hand wheel
- 5: 上紧固螺钉×2 On fastening screws ×2
- 6: 中间紧固螺钉×2 Middle fastening screws ×2
- 7: 下紧固螺钉×1 Under fastening screws ×1

安装说明: Installation Instructions

一、把直驱电机2 前端轴装上公三爪连接器，对应主轴上安装上母三爪连接及橡皮，电机出线口方向向右，注意主轴上的平面和电机轴平面的方向关系（电机定位），然后将电机套入主轴，上电机四个固定螺钉，电机安装完毕。

Mounted male three-jaw connector on front-end shaft direct drive motor2, Corresponding spindle mounted on female three-jaw connector and rubber. The direction of motor and outlet is to right. Pay attention to relationship (motor positioning) of the direction of the spindle on the plane and the plane of the motor shaft, and then sets the motor into the spindle, the motor on the four fixing screws, the motor installed.

二、取电控放置于电机旁，抽出电控上的编码器线插至电机编码器口，再取电机电源线头和电控电源口对接，在电控内部穿上紧固螺钉5，螺钉上在穿上定位橡圈

Take power control next to the motor, extract the encoder line on the electronic control plug to the motor encoder mouth, and then take the motor power head butt and electronically controlled power port, put inside the electric hole on the fastening screws 5, put the screws in position.

三、将电控的电机室对准电机慢慢套入机头，调整两条连接线置于电控右端，完全套入后穿入电控中间紧固螺钉6 不打紧，旋转上紧固螺钉与机头螺孔连接不打紧，再穿入电控下紧固螺钉，检查并调整电控轮廓与机头轮廓配合适当，依次打紧螺钉6、螺钉5、螺钉7，电控安装完毕。

Electronic control of the motor chamber alignment motor slowly set into the machine head, adjust the two cable placed on the right side of the electronic control perfectly. Fit into the intermediate fastening screws penetrate the electronic control not tight, the rotation on the fastening screws and machine. The connection does not tight to the head of the screw holes, and then penetrates the electronic control under the fastening screws, check and adjusts the contour and machine head contours of the electronic control with appropriate turn matter screws 6 screw 5, screws7, electrical control installed.

四、在电机后轴上套上手轮4，注意定位螺钉与轴平面对齐上紧。

Put hand wheel 4 on the rear axle of motor, pay attention to the positioning screw axis plane aligned

在运行你的锁眼机之前，请仔细阅读本使用说明书内的指令并以正确、有效的方式里操作它。

BEFORE OPERATING YOUR LOCKSTITH MACHINE, PLEASE READ THIS INDTRUCTION MANUAL CAREFULLY IN ORDER TO OPERATE IT IN THE CORRECT AND EFFICIENT MANNERS.

运行中警告 CAUTIONS IN OPERATION

<p>1. 机器从滑轮的正面观察应该逆时针方向旋转，注意不要让缝纫机反方向旋转。</p> <p>2. 在没有加油之前，不允许开动机器。</p> <p>3. 在试运行前，请从机器中拿出线轴箱和针线。</p> <p>4. 每天在缝工作之后应及时清理缝钩和机器线轴，另外应经常检查缝纫机油的油量。</p> <p>5. 为防止人身事故的发生，缝纫机在运行戒电机在转动过程中，请不要将手指、头发、衣服等靠近手轮，也不要任何东西放到机器上。</p> <p>6. 如果你的机器配有封带，为了保护你的手指和和眼睛，在进行操作前，请将它们除去。</p>
<p>1. The machine should rotate counterclockwise as observed from the pulley. Take care not to rotate the machine in the opposite direction.</p> <p>2. Never start the machine before filling the machine base with lubricating oil.</p> <p>3. Remove the bobbin case and the needle thread from the machine before performing the trial operation.</p> <p>4. Clean up the sewing hook and the bobbin thread trimmer every day after sewing work. Also check the level of the lubricating oil.</p> <p>5. Never bring your fingers or hair close to, or place anything on the hand wheel during operation. It may lead to serious peraonal injuries.</p> <p>6. If your machine is provided with a belt cover, finger guard and eye guard, never operate your machine with any of them removed.</p>

6: 规格 SPECIFICATION

型 号	781E	782E	783E	781EK
用 途 Application	一般布料，针织布料等的锁眼机 Buttonholing for ordinary cloth , knit , etc			
锁眼宽度 Buttonhole length	2.5-4mm	2.5-5mm	2.5-5mm	2.5-4mm
切刀长度 Bar-tack width	6.4-19mm (1/4"-3/4")	6.4-25.4mm (1/4"-1")	6.4-25.4mm (1/4"1 - 1/4")	6.4-19mm (1/4"-3/4")
机 针 Needle	DPX5 #11J-#14J			
压脚高度 Presser lift	12mm			
使用机油 Lubricating oil	NO.1新机油			

7: 缝迹形式 TYPES OF STITCHES

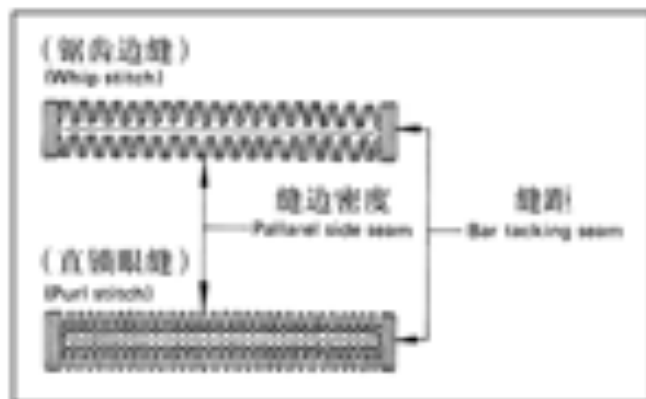

本缝纫机有两种线迹形式，它们是：

1. 此缝纫机锯齿边缝和
2. 直锁眼缝。

(锯齿边缝)

布的表面只有上线，背面是底线的锯齿状缝迹。

(直锁眼缝)

增强上线张力，上线直线通过，底线左右锁眼的缝迹。

This machine is capable of forming two different types of stitches, namely whip stitch and purl stitch.

(Whip stitch)

The whip stitch is formed in zigzag showing the needle thread only on top of fabric, and the bobbin thread on the bottom.

(Purl stitch)

When applying higher tension to the needle thread to permit it to pass straight through fabric, the purl stitch is formed by the bobbin thread which is pulled over from both sides to the center line.

8: 缝纫机头的安装 SETTING UP THE MACHINE HEAD

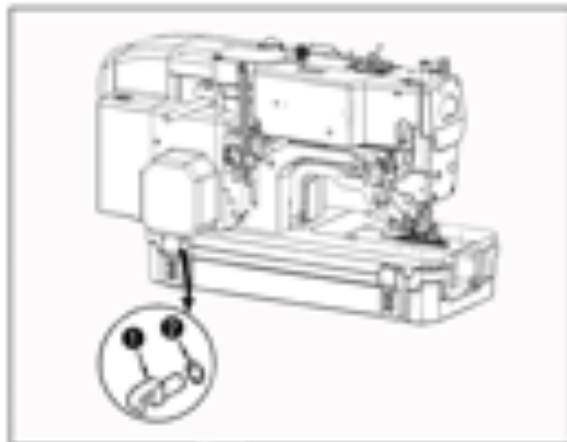

将铰链①装入机头。

然后，将机头放在机座上。

Insert hinge ① into machine head.

Then, place the machine head on the machine base.

不得挤压电控部位及剪线部件。

9: 梭心的安装方法 ATTACHING THE BOBBIN

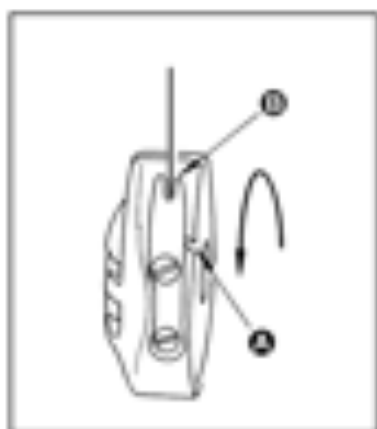

1. 手拿梭心，让线往左绕的方向，把它放入梭壳。

2. 把线穿过梭壳的穿线口②，然后把线往③方向拉，从线张力弹簧下面的穿线口④拉出来。

• 拉底线C，确认底线是否梭心与箭头的方向相同。

1. Hold and place a bobbin into the bobbin case so that the bobbin is wound counterclockwise.

2. Passing the thread through thread outlet ② of the bobbin case, pull the thread, and the thread can be drawn out from thread outlet ④, passing under the bobbin winder tension spring.

• Set the bobbin so that it rotates in the arrow direction when the bobbin thread is pulled.

10: 梭壳的安装方法 INSTALLATION/REMOVAL OF BOBBIN CASE

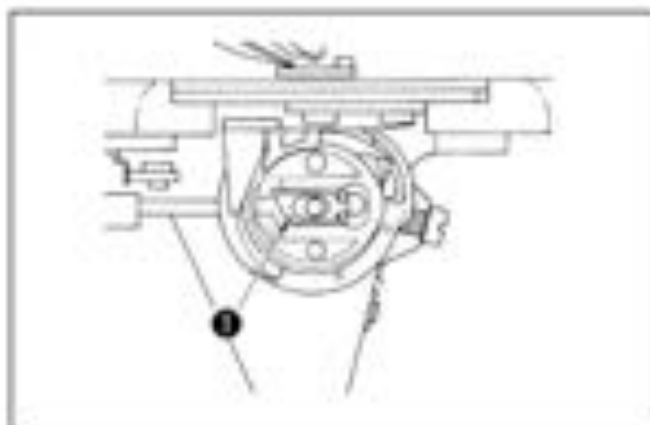

1. 撬起梭壳扣爪 ①，取下梭壳。撬起扣爪时梭壳时梭心不会掉出来。
 2. 安装时请把梭壳插到底，扣爪闭上。
1. Lift up and hold bobbin case latch lever ① between two fingers to remove it from the hook. A bobbin does not fall off the bobbin case while the latch lever is lifted up.
2. For installation of the bobbin case, push the bobbin case into the hook so that it is supported by the hook shaft, and then snap in the latch lever.

11: 机针的安装方法 HOW TO INSTALL THE NEEDLE

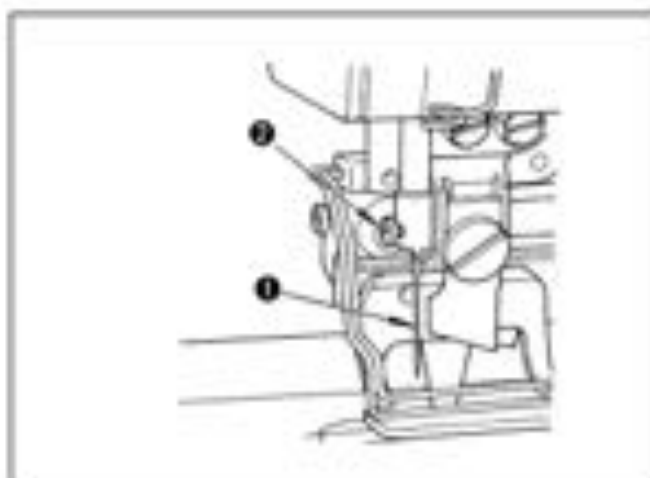

- ★切断电源。使用DP×5J机针
1. 拧松机针固定螺钉 ②，手拿机针，把机针 ① 凹部横向转到前侧。
 2. 然后把机针插进针杆孔的深处。
 3. 拧紧机针固定螺钉。
- ★Turn off the motor power. Use a DP×5J needle.
1. Loosening needle setscrew ②, hold needle ① with its recessed part facing toward the operator.
 2. Insert the needle fully into the needle clamping hole, and
 3. Securely tighten the needle setscrew.

12: 线架的安装 SETTING UP THE THREAD STAND

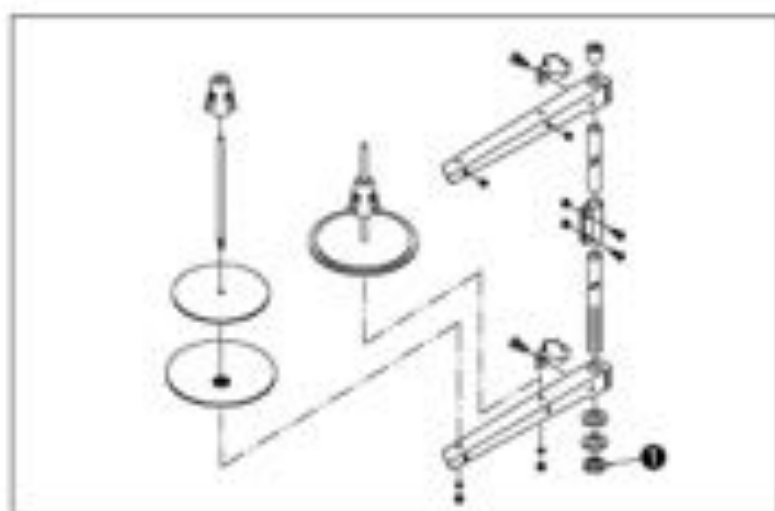

把立式线架放入台板孔。拧紧螺母 ① 固定在台板上。调整配线的高度。让电源线从杆 ② 中穿过。

Assemble the thread stand, and fix it in the table. Then tighten lock nut ① to fix the thread stand. If ceiling wiring can be made, pass the power cable through spool rest rod ②.

13: 加油 LUBRICATION

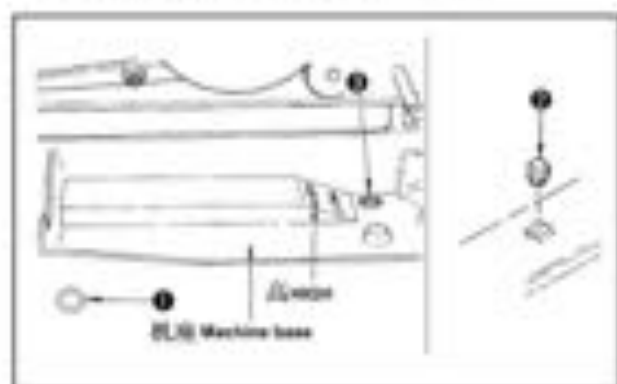

1. 把NO.1新机油加入到油槽，加到HIGH标记的位置。
 2. 油量低于油标①时，应往油槽里加油。
 3. 当机器正常运转时可以通过油视窗②看到机油。（低速运转时油量会少一些。）
- 油脏污之后，请拧松放油螺丝③排出脏油，并换新机油。

Before starting the machine

1. Fill the oil reservoir of the machine base with New Defrix Oil No. 1 up to the level indicated by "HIGH".
 2. Supplement the oil when the oil level has lowered below the bottom line of oil gauge ①.
 3. When the machine has been properly lubricated, the oil is seen to run through the pipe from oil sight window ② (Low speed operation permits easier observation of the lubricating oil)
- Drain dirty oil by loosening oil drain screw ③ and fill the oil reservoir with fresh oil.



- 旋梭油量的调节
用调节螺丝④调节大旋梭的油量，用调节螺丝⑤进行微量调节。把调节螺丝往里拧油量变多。
- Adjusting the lubrication for the sewing hook
Adjust the volume of lubricating oil supplied to the sewing hook by turning oil adjusting screws ④ for rough adjustment, and ⑤ for fine adjustment, oil volume is reduced when turning the screws clockwise.

14: 底线的绕线方法 WINDING THE BOBBIN

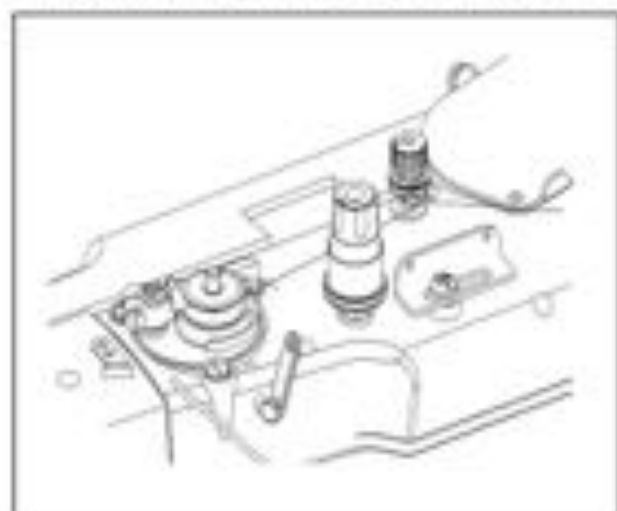

1. 把梭心插到绕线轴上。
 2. 如图所示进行穿线，并把线在梭心上绕几圈。
1. Fit a bobbin onto the bobbin winder shaft.
 2. Take the thread from the spool and pass it through the guides in the numerical order shown in the figure, and wind the end of the thread several turns around the bobbin.

15: 上线的穿线方法 THREADING THE NEEDLE-THREAD

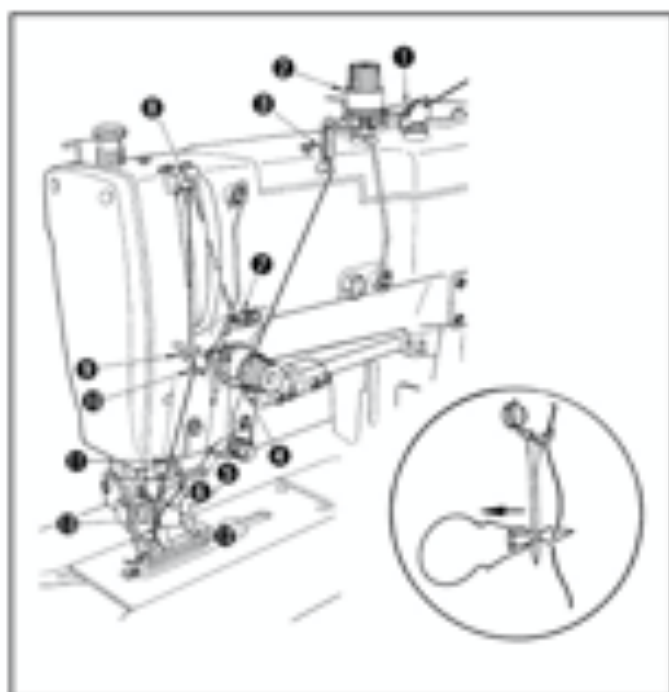

1. 如图所示穿上线。
 2. 线穿针时，轴使用附属的穿线器穿线非常方便。
1. Pass the needle thread in the order as shown in the figure.
 2. The threading can be done easily by using the needle threader supplied with the machine.

16: 手动送布手柄 MANUAL FEED HANDLE

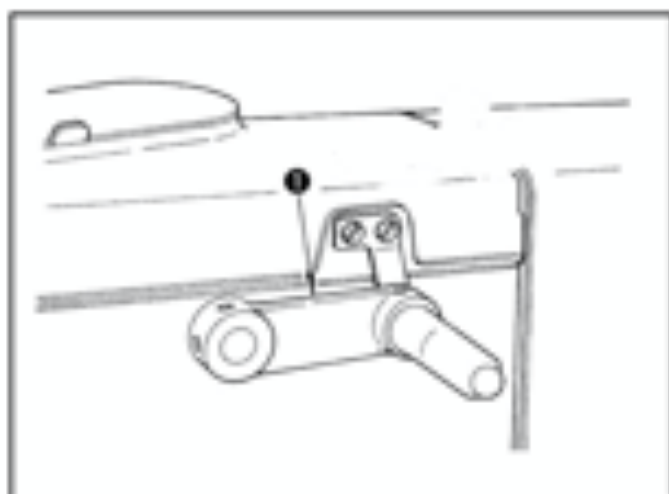

紧急停止后，或中途线断后，再次开始缝制是，转动手动送布手柄①送布面构就开始动作。(注意)手动送布手应在确认了机针没有扎到布之后再转动。

When you want to feed fabric manually after giving an emergency stop or to resume sewing from the point at which thread was broken, rotate manual feed handle ① to operate the cloth feeding mechanism. (NOTE) Confirm that the needle does not stick in fabric before turning the manual feed handle.

17: 防止切刀掉落 HOW TO HOLD THE DESCENDING KNIFE

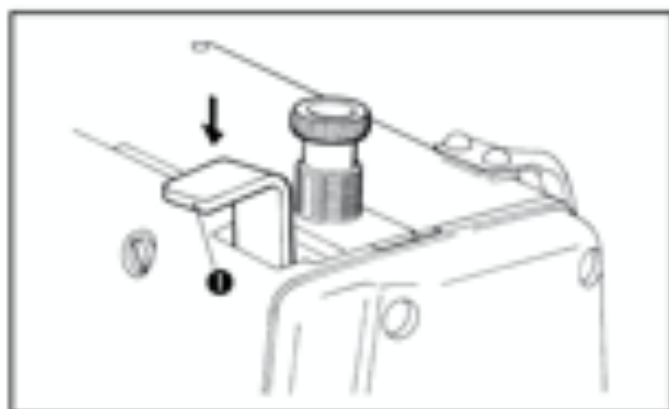

紧上线和底线被切断时，或不想让刀落下时，在缝制机停止之前把固定拨杆①轻轻向下按压，切刀就不会下落

When you do not want to cut fabric after sewing because of thread breakage or some other reasons, keep on pressing down knife stop lever ① lightly until the machine stops. Then the knife will not descend.

18: 针数的变换方法 CHANGING THE NUMBER OF STITCHES

代号 Symbol	小齿轮齿号 No. of teeth of small gear	大齿轮齿号 No. of teeth of Large gear	代号 Symbol	小齿轮齿号 No. of teeth of small gear	大齿轮齿号 No. of teeth of Large gear
A	34	145	I	93	200
B	42	300	①	100	190
C	46	285	K	105	180
D	50	268	②	110	170
③	74	252	M	115	160
F	79	238	④	121	152
⑤	83	225	O	130	145
H	88	212			

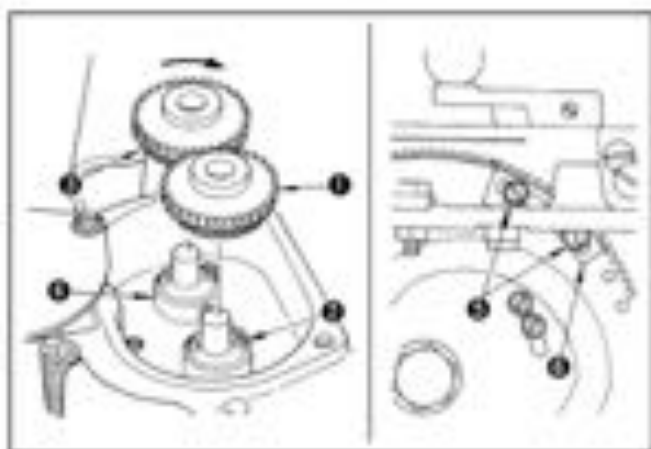

• 更换齿轮

1. 更换齿轮，可以变为表中所述的针数。
2. 齿轮上均刻有A, B, C...的英文字母和123, 156的数字。
3. 用英文字母相同的齿轮进行组合。
4. 后面安装的齿轮上刻的数字表示此时的针数。(○里的为标准附属品, 其它则为另外订购零件)

• 齿轮的安装

1. 从操作人员方面看，把齿轮①插进前面的更换齿轮座②的设链上。
2. 把齿轮①向箭头方向转动，插进后面的更换齿轮座③的设链。

• 停车凸轮位置的调整

- 拧松固定螺栓⑦，调整停车凸轮⑥的位置。

• Spur gears

1. By selecting the spur gears, you can control the number of stitches as shown in the table
2. Alphabetical marks like A, B, C, etc, and numerals like 123, 152, etc are both engraved on each spur gear for identification
3. Use a combination of gears which have the same alphabetical marks
4. The numeral engraved the gear installed in the rear position will represent the number of stitches provided by the then combination of spur gears

The circled alphabetical symbols in the above table show that the gears are included in the standard accessories. All other gears are optional attachments

• Attaching the spur gears to their shafts

1. Push gear ① into the shaft so that it is securely fixed by the pin on gear bushing ② located nearer to an operator
2. For installing gear ① on the pin of rear gear bushing ③, push gear ① into the shaft while turning it in the arrow direction.

• Adjusting the stop cam position

Loosen setscrews ⑦, and adjust the position of a stop cam ⑥

19: 机针和旋梭的关系 NEEDLE-TO-HOOK RELATION

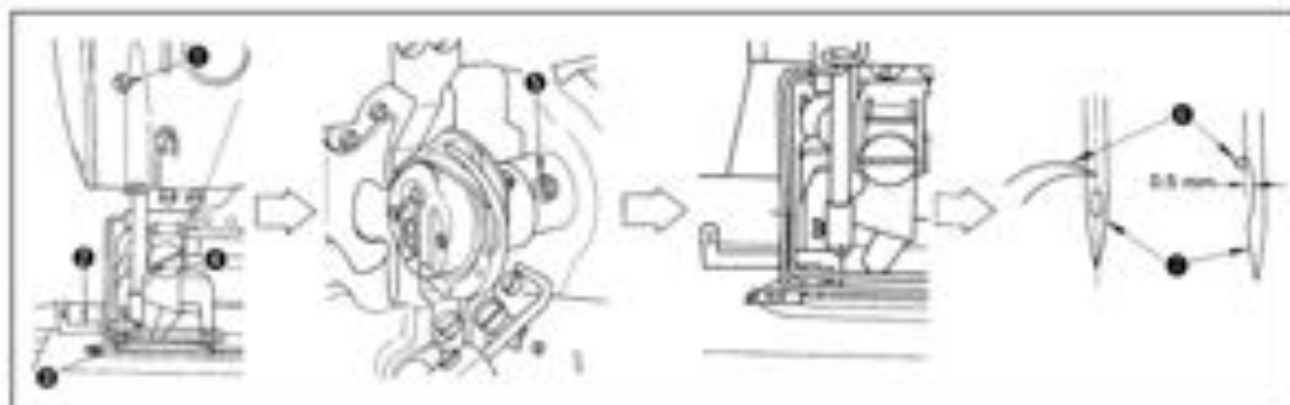

●机针和旋梭请按如下所述进行调整。

1. 把针杆降到最下点，让机针落到针板的针孔中央。

2. 拧松针杆套管固定螺丝 ①。

(决定针杆的高度)

3. 用同步尺 ② 的“1”的部分放入针板 ③ 和针杆 ④ 下端之间，并让针杆碰到标尺。

4. 拧紧针杆套管固定螺丝。

(决定旋梭的位置)

5. 用附属的棒扳手拧松两个旋梭轴接头固定螺丝 ⑤。

6. 向正规方向转动驱动皮带轮，针杆成为从最下点开始上升的状态。

7. 把同步尺的“2”的部分放到针板和针杆下端之间，针杆碰到同步尺时。

8. 让旋梭尖 ⑥ 对准机针 ⑦ 的中心，旋梭尖和机针之间的间隙为约0.05mm，把旋梭轴接头固定螺丝拧紧。

(注意) 发生跳针时，请让针杆的高度比同步尺“1”低0.5mm左右。

● Set the needle to hook relation in the following way:

1. Bring down the needle bar to the lowest point when the needle is coming down through the center of the needle hole on the throat plate.

2. Loosen needle bar connection screw ①, and adjust the height of the needle bar.

(Setting the needle bar).

3. Insert the part "1" of timing gauge ② into the gap between the bottom end of needle bar ④ and throat plate ③.

4. Retighten the needle bar connection screw to adjust the position of the sewing hook.

(Setting the hook).

5. Loosen setscrew ⑤ of the hook sleeve by the bar spanner supplied with the machine.

6. Rotate the driving pulley in the correct direction until the needle starts to go up from its lowest point.

7. Insert the part "2" of the timing gauge into the gap between the bottom end of the needle bar and the throat plate, where the bottom end of the needle bar touches the top of the part "2" of the timing gauge.

8. Align blade point ⑥ of the sewing hook with the center of needle ⑦, and make adjustment so that a clearance of approx 0.5mm (1/64") is provided between the needle and the blade point of the hook. Then securely retighten the setscrew of the hook sleeve.

(NOTE): If stitches are skipped, lower the needle bar by approx 0.5mm (1/64") from the timing gauge "1".

20: 线张力 THREAD TENSION

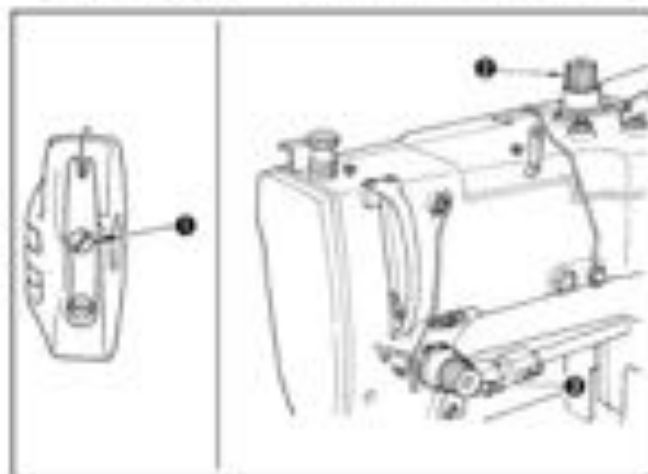

★ 直锁眼缝的线张力

1. 用梭壳张力螺丝 ❶ 把底线张力调节为0.15-0.2N左右。
2. 调整第一线张力器 ❷ 缝制出漂亮的锯齿边缝那样的缝迹。如果背面线头露出的话，请调紧第一线张力器。
3. 对于平行部A的锯齿形状，请用第二线张力器 ❸ 调节。

★ 锯齿边缝的线张力

1. 用张力螺丝 ❶ 把底线张力调节为0.4-0.5N左右。

2. 更换第一线张力器 ❷ 和第二线张力器 ❸ 的调节弹簧。（第二线张力器要稍弱一些）
3. 用第二线张力器 ❸ 进行调节，不让缝脚完了后脱线。
4. 用第一线张力器 ❷ 调节平行部，加固缝脚的缝迹。

★ Adjusting the thread tension for purl stitch:

1. Adjust the bobbin thread tension to approx. 15 to 20g by adjusting screw ❶ of the bobbin case.
2. Adjust tension controller No. 1 ❷ for proper needle thread tension so that the bar-tack part is formed by well-shaped whip stitches. If the tension is too low bar tacking seam may form thread knots on the rear face of fabric.
3. Adjust tension controller No. 2 ❸ for proper tension of the parallel side seams by judging from the stitch formation.

★ Adjusting the thread tension for whip stitch:

1. Adjust the bobbin thread tension to approx 40 to 50g by adjusting screw ❶ of the bobbin case.
2. Exchange the adjusting springs of tension controllers No.1 ❷ and No.2 ❸ each other (the tension controller No.2 will have a weak spring).
3. Adjust tension controller No.2 ❸ to prevent raveling off at the end of a seam.
4. The stitches of the parallel sides or bar-tack can be adjusted by tension controller No. 1 ❷.

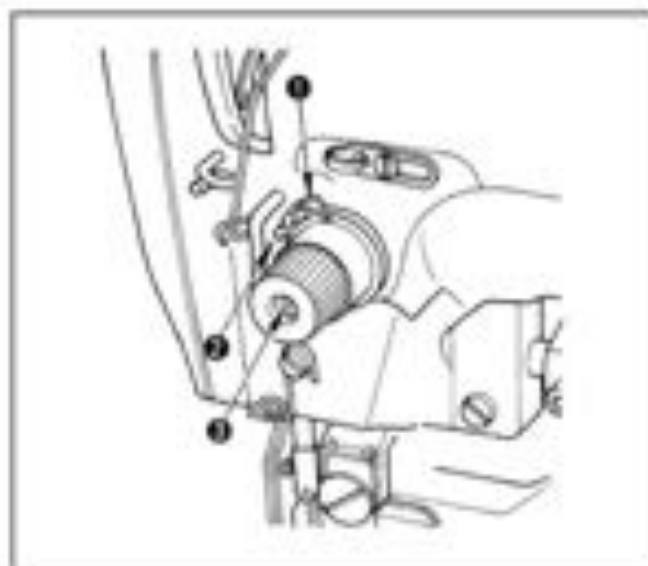

★ 拉线弹簧（直锁缝）

把拉线弹簧 ❶ 的拉线量调节成8-10mm，把启动时的张力强度调节为0.1-0.2N。

变更拉线弹簧的动作范围时，请拧松螺丝 ❷，把细螺丝刀插到线张力杆 ❸ 的切缝处转动调节。

变更拉线弹簧的强度时，请在螺丝 ❹ 拧紧的状态下，把细螺丝刀插到线张力杆 ❸ 的切缝处转动调节。向右转动拉线弹簧和强度变大，向左转动变弱。

• Adjusting the thread take-up spring (for purl stitch)

The suitable range of the stroke of thread take-up spring ❶ is from 6 to 8mm with a starting tension of 20 to 50g.

For adjusting the stroke of the thread take-up spring, loose screw ❷ and insert a thin screwdriver into the slit of tension post ❸ to turn the tension post.

To adjust the tension of the thread take-up spring insert a thin screwdriver into the slit of tension post ❸ to turn it, with screw ❷ tightened. The tension of the thread take-up spring increases when the tension post is turned clockwise, and decrease when turned counterclockwise.

21: 缝边长度(送布量)的调节 ADJUSTING THE OVEREDGING LENGTH (BUTTONHOLE LENGTH)

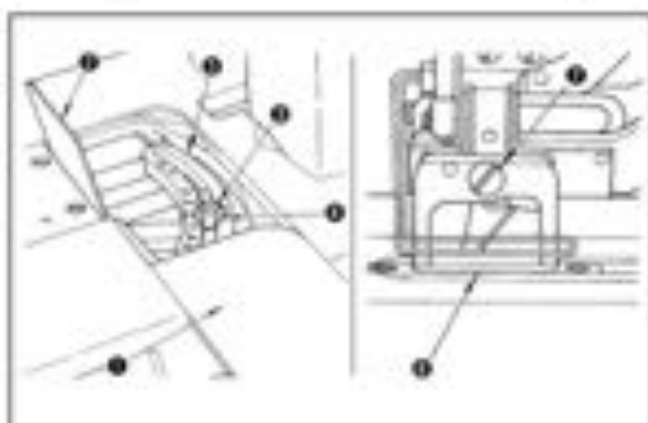

1. 拉出外罩 ❶，就可以抬起外罩 ❷。
2. 用附属的扳手拧松螺母 ❸，把指针 ❹ 对准送布曲柄 ❺ 上希望的刻度(与切布刀宽度相同的尺寸)，然后拧紧螺母 ❸，请不要把螺母 ❸ 拧下来。
3. 进行试验缝制，微调整让切刀不切加固缝部。

• 压脚的更换

请使用接近钮扣眼长度的压脚步 ❶，拧松压脚固定螺 ❷，就可以更换压脚。

1. Pull out cover ❶, and raise cover ❷.
2. Loosen nut ❸ by the spanner supplied with the machine. Set point ❹ to a desired length on scale (this length is the same with the knife width), and then retighten nut ❸.
3. Through your trial sewing, adjust the overedging length accurately to the extent that the bar tacking seams are not cut by the knife.

• Changing the work clamp check

Use work clamp check ❶ having the size nearly the same as that of a buttonhole length.

By removing setscrew ❷, a work clamp checks can be changed together with a work clamp check holder as a set.

22: 锁眼宽度以及缝锁基准位置的调节 ADJUSTING THE OVEREDGING WIDTH AND OVEREDGING REFERENCE POSITION

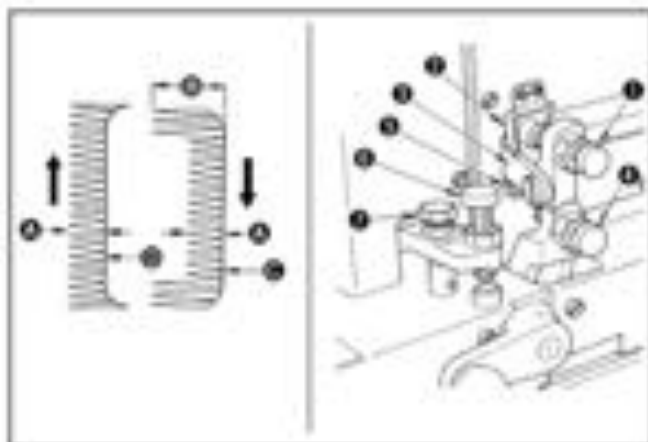

机针的摆动以机针摆动的右侧为基准。调整时请按照以下要领进行。

1. 摆动宽度 ❶，移动螺丝 ❶ 把指针 ❷ 对准刻度板 ❸ 上希望的刻度，实际的摆动宽度是刻度的1/2的量(单位: mm)。
2. 加固缝宽度 ❹，移动螺丝 ❹ 把指针 ❷ 对准刻度板的指针 ❸ 指示的刻度，设定为摆动宽度的2倍。
3. 右基线 ❺ 的位置，移动螺丝 ❺，设定到切

刀切不了线的位置。拧紧螺丝 ② 右基线向左移动。

4. 进行试验缝。以进行上述的微调整。

5. 左基线 ③ 的位置，因变更摆动宽度的位置也不变动，所以不需调整。但是切刀切左基线时，拧紧螺丝 ② 让其向左移动。

The needle swings from right to left with the right base line established as the reference position.

Perform the adjustment as follows:

1. To adjust stitch width ④, screw in or out screw ①, and set pointer ② to a desired value on scale plate ③. The actually sewn stitch width will be the half of the set scale value(mm).
2. For adjustment of bar tacking width ④, screw in or out screw ①, and set pointer ② to the value indicated by scale plate pointer ②, making the bar tacking width twice as large as the stitch width.
3. Adjust the position of right base line ⑤ by screwing in or out screw ② so that it is kept away from the cutting line of the knife. As screw ② is screwed in, the right base line moves to the left.
4. Through your trial sewing, further perform fine adjustment.
5. It is not necessary to adjust the position of left base line ③ since it remains unchanged when the stitch width is changed. However, the left base line should be moved to the left by screwing in screw ② if it is cut by the knife.

23: 压脚的压力调整 ADJUSTING THE PRESSER BAR PRESSURE

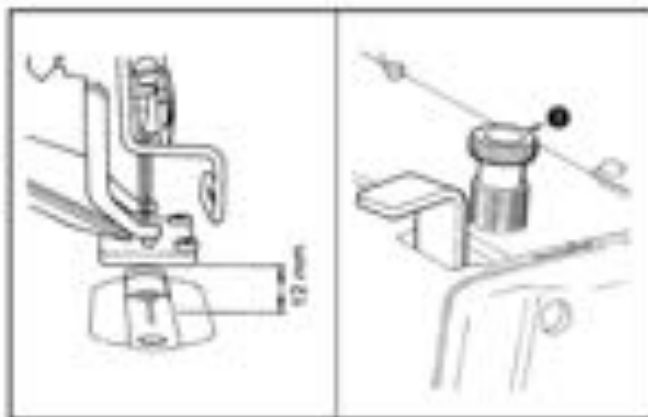

踏板踩到底时的压脚提升量为12mm。

布压脚的压力用压脚调节螺丝 ① 调节。拧紧调节螺丝后，布压脚压力变大，布不容易出褶。

The presser bar goes up 12mm when the pedal is fully stepped down.

To adjust the pressure applied by the presser bar to fabric, turn presser spring regulator ①. When the pressure is not enough to prevent fabric from puckering, turn regulator ① clockwise.

24: 切刀的更换 REPLACING THE KNIFE

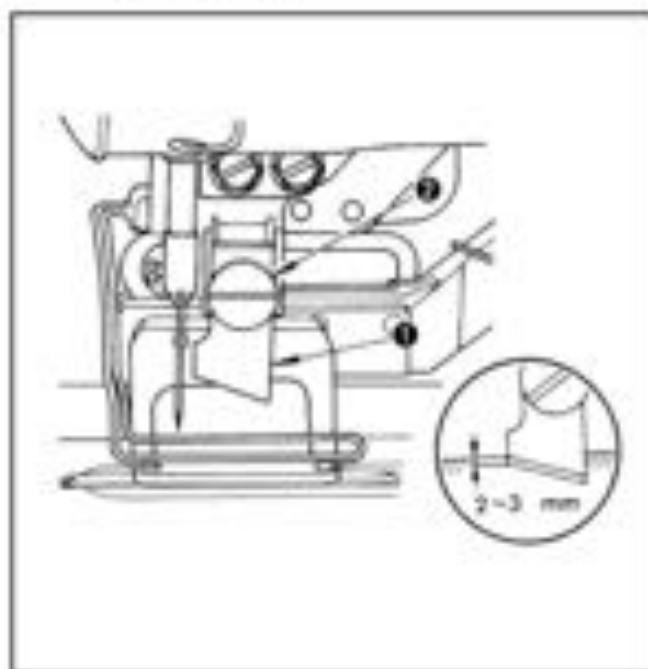

研磨切刀或更换新切刀时，请按照如下要领进行更换。

1. 拧松切刀固定螺钉 ②，把切刀 ① 和垫片一起卸下。
2. 安装时，下降到切刀最低点，让切刀和护针器上面的距离为2~3mm，拧紧切刀固定螺丝。（注意）请一定放上垫片。

When sharpening or replacing the knife, remove it as follows:

1. Loosen setscrew ②, and remove knife ① together with the washer.
2. Attach the knife to the knife holder so that the higher end of the slanted knife blade comes down 2 to 3mm above the surface of the throat plate when the knife is brought down to the lowest position.

(NOTE): Do not forget to install the washer when retightening the setscrew.

25: 上线切线的调整 ADJUSTMENT OF THE NEEDLE THREAD TRIMMER

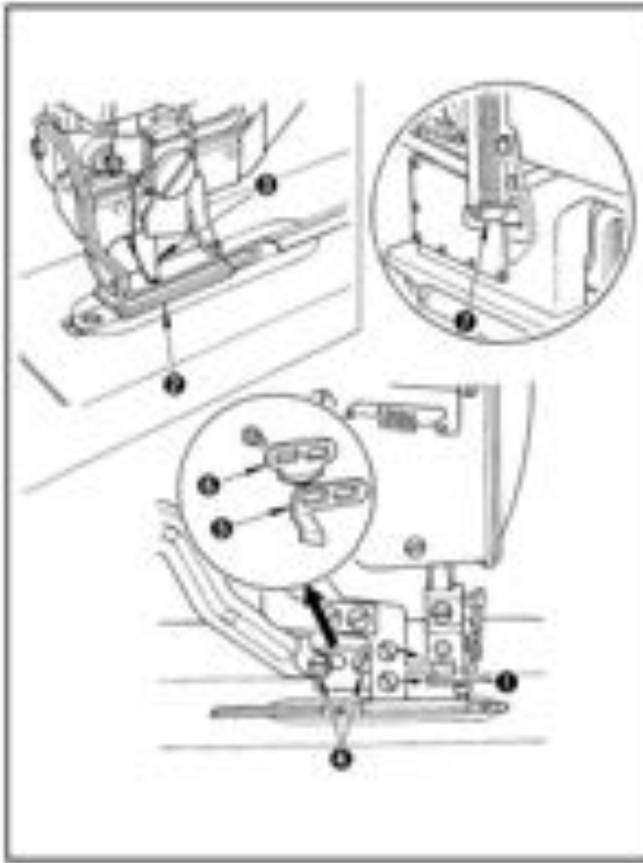

• 切刀的安装

拧松螺丝①，下降压脚使压脚②和切刀③不相碰。上线可以剪短。

但是缝制布层时，压脚会倾斜所以把切刀的位置变得稍高一点。

• 切刀关闭的同步时间

切刀伸到最长时，调整切刀关闭的同步时间。拧松螺丝⑤，把上线切刀动作板A④前后移动，来调节。往前移动关闭的同步时间推迟，同时关闭量也变少。

(注意)切刀关闭之后，请确认还应有0.3-0.5 mm左右的富裕。没有关闭富裕时，切刀上线切刀动作板相接触压脚提升拔杆⑥变重。

• 切刀张开的同步时间

调整切刀使切刀在从开始缝的2.5-3mm左右的地方，渐渐的开始张开。拧松螺丝⑤，前后移动上线切刀动作板B④来进行调节。向前移动张开时间提前。

(注意)定位的上线切刀动作板A一定不能偏斜。

• Attaching the trimmer

Loosen setscrew ①, and adjust the height of trimmer ③. Set the height of trimmer ③ as low as possible, provided that it does not touch work clamp check ②, in order to minimize the length of remaining thread on the needle after trimming.

• Closing timing of the needle thread trimmer

Adjust the closing timing of the needle thread trimmer so that the trimmer completely closes when it advances farthest.

To perform the adjustment, loosen screw ⑤, and move needle thread trimmer driving plate A ④ back and forth. When the needle thread trimmer driving plate is moved towards you, the closing timing is delayed with reduced amount of closing.

(NOTE) Confirm that an allowance of 0.3 to 0.5mm is left between the blades of the trimmer when the trimmer has completely closed.

If there is no such allowance the trimmer would interfere with the operation of the needle thread trimmer driving plate, preventing smooth movement of lifting lever ⑥.

• Opening timing of the needle thread trimmer

Adjust the timing of the thread trimmer so that the trimmer begins to open gradually at a distance of approx. 2.5 to 3mm (3/32" to 1/8") from the start.

To perform the adjustment loosen screw ⑤, and move needle thread trimmer driving plate B ④ back and forth. As it moves towards you, the trimmer begins to open earlier.

(NOTE) Take care not to cause the already fixed needle thread trimmer driving plate A to get out of position.

26: 上线切线动作曲轴和限制板的调整 ADJUSTMENT OF NEEDLE THREAD TRIMMER HOLDER AND LIMITING PLATE

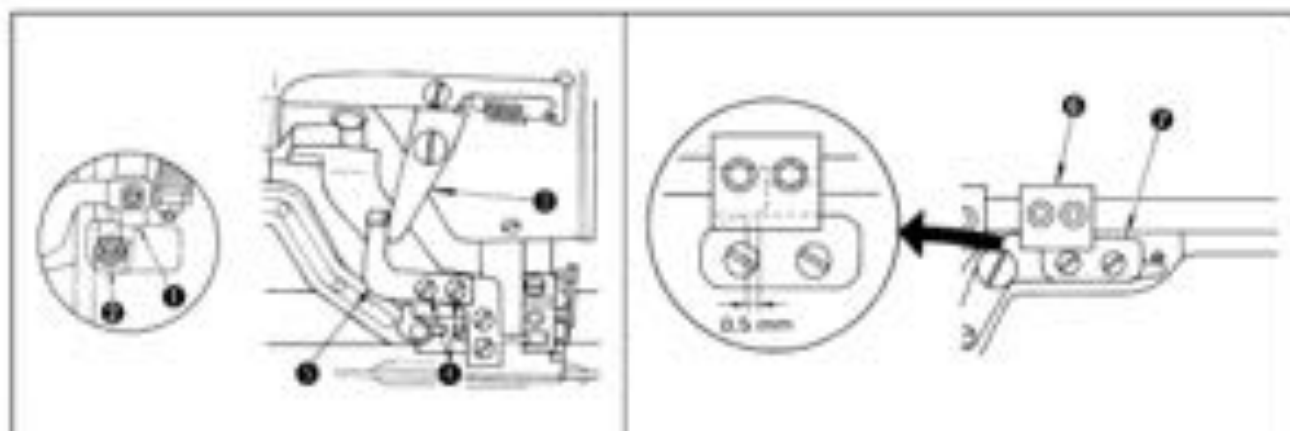

缝制机低速启动时（多钩B ① 和钩A ② 咬合时），拧松固定螺丝 ③，让限制板落到阻挡曲柄 ④。

上线切刀张开时，让上线切线动作曲柄 ⑤ 和动作凸轮 ⑥ 咬合0.5mm。

Loosen setscrew ③, and install and adjust limiting plate ⑤ so that it comes in contact with the blocking arm ④ at the time of slow start of the machine (When latch B ① is engaged with latch A ②).

Needle thread trimmer holder ⑤ should be installed in such manner that it engages with cam ⑥ by 0.5mm (1/64") when the needle thread trimmer opens.

27: 切刀落刀时期的调整 TIMING FOR DROPPING THE KNIFE

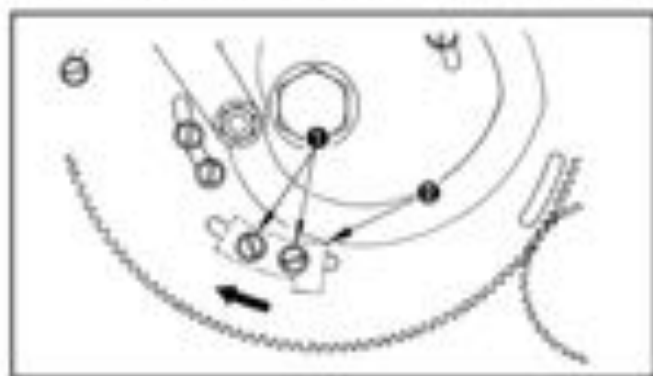

拧松固定螺丝 ①，向箭头方向移动切刀动作凸轮 ④，切刀落刀时间提前，反则推迟。缝制机停止的2-3针前让切刀落刀。

Loosen screw ①, and move knife tripping segment ④ in the direction shown by the arrow, and the knife will drop earlier. adjust it so the knife drops two to three stitches before the machine stops.

28：有关缝制的故障、原因及处理方法 TROUBLE,CAUSE,AND REMEDY

现象	原因	处理方法
1、上线断线	<ol style="list-style-type: none"> 1、第二线张力器过强。 2、拉线弹簧的强度、移动量过大。 3、旋梭尖有刺或有伤痕。 4、旋梭不同步。 5、线道有伤痕。 6、机针过粗。 	<ul style="list-style-type: none"> ○ 减弱第二张力器的张力 ○ 减弱拉线弹簧的弹力，或缩小移动量 ○ 磨平旋梭尖，或更换旋梭 ○ 用同步尺调整旋梭的同步 ○ 用布或锉刀磨平 ○ 更换成粗针
2、上线脱线	<ol style="list-style-type: none"> 1、上线切线剪打开过早。 2、放下压脚上线切刀便打开。 3、开始缝时不能为直缝顺缝。 4、上线的穿线方法不对。 	<ul style="list-style-type: none"> ○ 往后移动上线切线动作板B。 ○ 往后移动上线切线动作板B。 ○ 减弱第一线张力器的张力。 ○ 正确的穿线。
3、平行部缝迹不整齐	<ol style="list-style-type: none"> 1、第二线张力器过弱。 2、挑线弹簧过强，活动范围小。 3、底线张力过强。 	<ul style="list-style-type: none"> ○ 增强第二线张力器。 ○ 重新调整挑线弹簧。 ○ 减弱底线张力。 (缝内边缝0.15-0.2N)
4、始缝缝迹不整齐	<ol style="list-style-type: none"> 1、第一线张力器过弱。 2、上线切线位置过高。 3、挑线弹簧活动范围过大。 	<ul style="list-style-type: none"> ○ 增强第一线张力器。 (0.15-0.3N) ○ 降低高度，但不要碰到压脚。 ○ 缩小挑线弹簧的活动范围，增大弹簧压力。
5、第一加固缝部上线从布的下面堆线	<ol style="list-style-type: none"> 1、第一线张力器过弱。 2、底线张力过强。 	<ul style="list-style-type: none"> ○ 增强第一线张力器。 ○ 减弱底线张力。(0.15-0.2N)
6、缝迹鼓起	<ol style="list-style-type: none"> 1、底线张力过弱。 2、底线从梭壳脱出。 	<ul style="list-style-type: none"> ○ 加强底线张力。 ○ 正确的穿线。
7、跳线	<ol style="list-style-type: none"> 1、压脚大。缝扣孔小。 2、布料薄。 	<ul style="list-style-type: none"> ○ 换成小压脚。 ○ 推迟机针和旋梭的同步时间。 (把针杆约下降0.5mm左右)。

Trouble	Cause	Remedy
1. Needle thread is broken.	(1) The tension of the tension controller No.2 is too tight. (2) The tension or the stroke of the take-up spring is too great. (3) Blade point of sewing hook has burr or scratches. (4) Poor timing of the sewing hook. (5) The thread path has scratches. (6) The needle is too thin.	<ul style="list-style-type: none"> ○Decrease the tension of the tension controller No.2 ○Decrease the tension or the stroke of the take-up spring. ○Buff the blade point of the sewing hook or replace the sewing hook. ○Readjust the sewing hook's timing by the timing gauge. ○Buff the thread path by cloth files, etc. ○Replace by a thick needle.
2. Thread slips out of the needle.	(1) The needle thread trimmer opens too early. (2) The needle thread trimmer opens when the work clamp check is coming down. (3) The whip stitch is not formed at the start of sewing. (4) Wrong threading.	<ul style="list-style-type: none"> ○Move back the needle thread trimmer driving plate B. ○Move back the needle thread trimmer driving plate B. ○Decrease the tension of the tension controller No.1. ○Perform correct threading.
3. Wobbling stitches are formed in the overedging seams.	(1) The tension disc No.2 is too loose. (2) The tension and stroke of the take-up spring is not enough. (3) Bobbin thread tension is too high.	<ul style="list-style-type: none"> ○Increase the tension of the tension disc No.2 ○Readjust the take-up spring. ○Decrease the bobbin thread tension (15 to 20g for pearl stitches).
4. Wobbling stitches are formed at the start of sewing.	(1) The tension disc No.1 is too loose. (2) The position of the needle thread trimmer is too high. (3) The stroke of the take-up spring is too great.	<ul style="list-style-type: none"> ○Increase the tension of the tension disc No.1 (15 to 30g) ○Lower the trimmer as low as possible, provided it does not come in contact with the work clamp check. ○Decrease the stroke of the take-up spring, and increase the spring pressure.
5. The needle thread at the first bar tacking comes out and lumps on the bottom of cloth.	(1) The tension disc No.1 is too loose. (2) The bobbin thread tension is too high.	<ul style="list-style-type: none"> ○Increase the tension of the tension disc No.1. ○Decrease the bobbin thread tension (15 to 20g).
6. Stitches float over cloth.	(1) Bobbin thread tension is not enough. (2) Bobbin thread slips out of the thread path on the bobbin case.	<ul style="list-style-type: none"> ○Increase the bobbin thread tension. ○Properly thread the bobbin case.
7. Stitches are skipped.	(1) The work clamp check is too large for the buttonhole. (2) The cloth is made of light-weight materials.	<ul style="list-style-type: none"> ○Change the work clamp check with a smaller one. ○Delay the time of the needle and the sewing hook. (Lower the needle bar by approx. 0.5mm (1/2"))

零件样本目录

PARTS BOOK CONTENTS

1、头部外装置关系.....	1
FRAME & MISCELLANEOUS COVER COMPONENTS	
2、上轴关系.....	3
MAIN SHAFT COMPONENTS	
3、下轴关系.....	5
HOOK DRIVING SHAFT COMPONENTS	
4、压脚棒、布送板关系.....	7
PRESSER BAR WORK CLAMP CARRIER COMPONENTS	
5、真棒摇动台关系.....	9
NEEDLE BAR FRAME COMPONENTS	
6、针摆幅调节关系.....	11
OVEREDGING WIDTH ADJUSTING COMPONENTS	
7、上线切刀关系.....	13
NEEDLE THREAD TRIMMER COMPONENTS	
8、下线切刀关系.....	15
SETTING UP THE MACHINE HEAD	
9、刀棒关系.....	17
KNIFE BAR COMPONENTS	
10、送布凸轮关系.....	19
FEED CAM & TRIPPING SEGMENT COMPONENTS	
11、电控关系.....	21
CONTROL BOX COMPONENTS	
12、安全保护关系.....	23
SAFE PROTECTION COMPONENTS	
13、压脚提升架、绕线器组件.....	25
LIFTING LEVER & BOBBIN WINDER COMPONENTS	
14、夹线器关系.....	27
THREAD TENSION COMPONENTS	
15、给油装置关系.....	29
LUBRICATION MECHANISM COMPONENTS	

1.头部外装置关系/FAME & MISCELLANEOUS COVER COMPONENTS

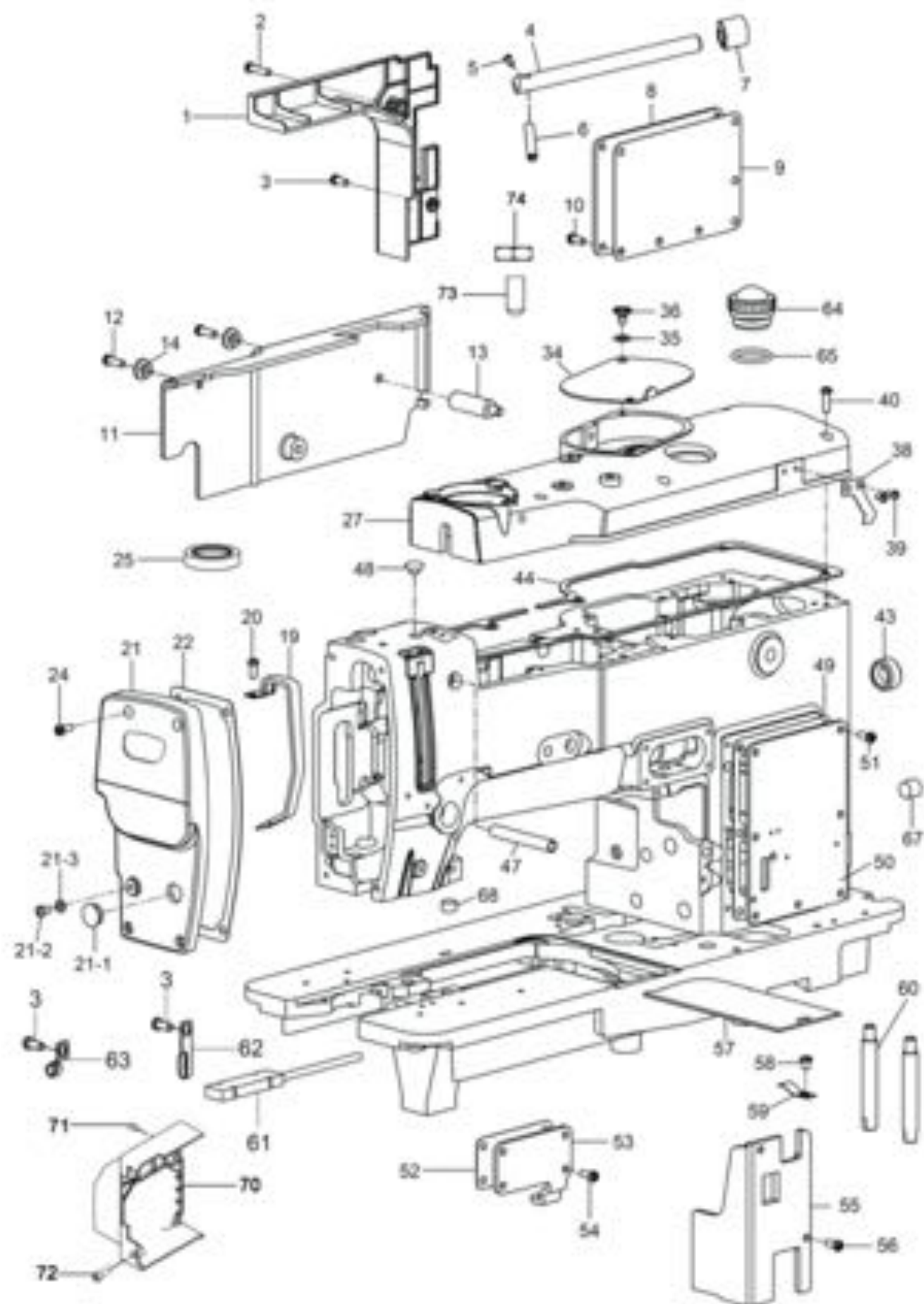

序号 NO.	注解 Note	件号 Part NO.	名称	Description	数量 Qty
1		40211001	机头侧盖	FRAME SIDE COVER	1
2		402S11001	螺钉	SCREW	1
3		402S11003	螺钉	SCREW	1
4		40202001	机头支撑臂	MACHINE ARM SUPPORT ROD	1
5		402S11002	螺钉	SCREW	1
6		40226001	弹性圆柱销	PIN	1
7		40222001	橡胶缓冲垫	RUBBER CUSHION	1
8		40212001	侧盖板	SIDE COVER	1
9		40222002	侧盖板衬垫	SIDE COVER GASKET	1
10		402S11003	螺钉	SCREW	7
11		40201001	机壳侧盖	FRAME SIDE COVER	1
12		402S11031	螺钉	SCREW	2
13		402S30001	螺钉	SCREW	1
14		40222003	缓冲垫	CUSHION	2
19		40212105	挑线杆防护罩	THREAD TAKE-UP LEVER OIL GUA	1
20		402S11004	螺钉	SCREW	2
21		40201064	面板	FACE COVER COMPLETE	1
21-1		40222005	面板塞	FACE COVER COMPLETE PLUG	1
21-2		402S11036	螺钉	SCREW	1
21-3		40228008	垫片	SPACER	1
22		40222038	面板衬垫	GASKET	1
24		402S11031	螺钉	SCREW	4
25		40222007	油封	OIL SEAL	2
27		40201061	顶盖	TOP COVER	2
34		40212003	齿轮箱盖	GEAR CASE COVER	1
35		40228001	碟形垫片	DISC SPRING	1
36		402S20001	轴位螺钉	HINGE SCREW	1
38		40212004	手制动钩	HAND STOP LATCH	1
39		402S11014	螺钉	SCREW	2
40		402S11001	螺钉	SCREW	6
43		40222009	橡胶插塞	RUBBER PLUG	1
44		40222037	上顶盖衬垫	TOP COVER GASKET REAR	1
47		40203001	停刀杆轴导向	KNIFE STOP LEVER SHAFT GUIDE	1
48		40222011	橡胶插塞	RUBBER RLUG	3
49		40222012	右侧盖板衬垫	SIDE COVER GASKET	1
50		40212098	左侧盖板	SIDE COVER	1
51		402S11003	螺钉	SCREW	7
52		40222013	油视窗衬垫	GASKET	1
53		40212006	侧盖	SIDE COVER	1
54		402S11003	螺钉	SCREW	4
55		40211002	侧盖板	SIDE COVER	1
56		402S11003	螺钉	SCREW	2
57		40212007	推板	BED SLIDE	1
58		403S11001	螺钉	SCREW	1
59		40227041	推板簧	BED SLIDE SPRING	1
60		402S30003	底板支撑螺钉	BED SCREW STUD	2
61		40330025	LED灯	LED	1
62		41312003	线夹	CABLE CLAMP	4
63		40112091	线夹	CABLE CLAMP	3
64		40211003	油视窗	OIL SIGHT WINDOW	1
65		40222014	油视窗垫片	OIL SIGHT WINDOW GASKET	1
67		40222016	盲孔塞	RUBBER PLUG	5
68		40223001	油毡	OIL FELT	2
70		40223001	电机侧盖	MOTOR SIDE COVER	1
71		413S13003	螺钉M4×6	SCREW	2
72		413S13019	螺钉M5×12	SCREW	1
73		40223001	柱塞螺钉	SCREW	1
74		40223001	螺母	NUT	1

2.上轴关系/MAIN SHAFT COMPONENTS

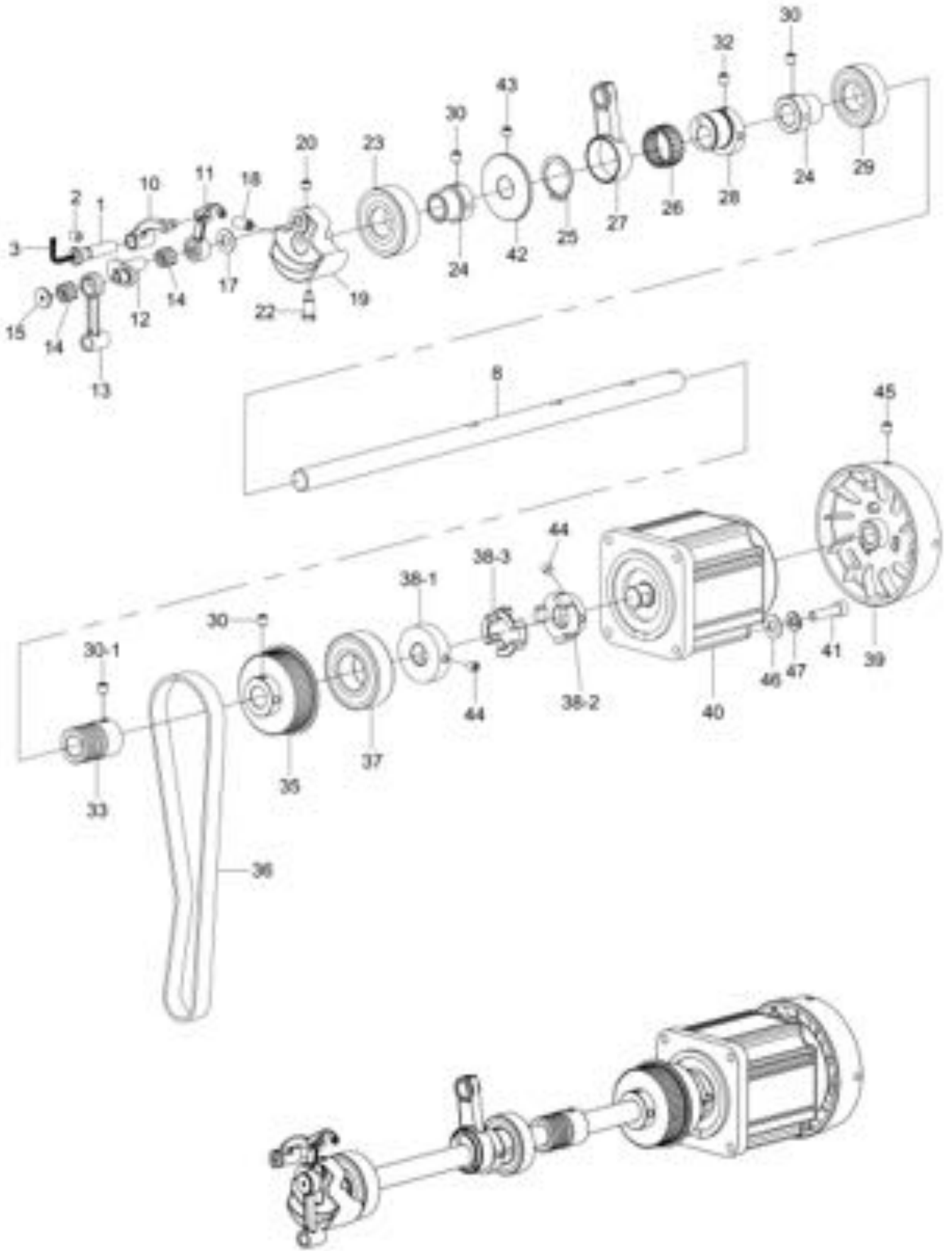

序号 NO.	注解 Note	件号 Part NO.	名称	Description	数量 Qty
1		40226002	铰链销	HINGE STUD	1
2		402S14001	螺钉	SCREW	1
3		12923018	油线	OIL WICK	1
4		-----			0
5		-----			0
6		-----			0
7		-----			0
8		40202054	上轴	MAIN SHAFT	1
10		-----	挑线连杆	THREAD TAKE UP CRANK	
11		4053800200	挑线杆组件	LINK TAKE UP	
12		40204001	针杆曲柄	NEEDLE BAR CRANK	1
13		40205001	针杆曲柄连杆	NEEDLE BAR CRANK CONNECTING ROD	1
14		-----	滚针轴承	NEEDLE BEARING	2
15		402S30004	左旋螺钉	END SCREW LEFT	1
16		-----			0
17		40228002	止推垫圈	THRUST WASHER	1
18		402S30005	螺钉	SCREW	1
19		40204002	平衡块	COUNTER WEIGHT	1
20		402S14002	螺钉	SCREW	2
21		-----			0
22		101S11003	螺钉	SCREW	1
23		B04009	轴承	BALL BEARING	1
24		40203003	轴套	BALL BEARING	2
25		H03012	挡圈25	THRUST COLLAR	1
26		B07016	滚动轴承	ROLLER BEARING	1
27		40205002	刀杆驱动连杆	KNIFE BAR DRIVING CONNECTING ROD	1
28		40210001	刀杆传动偏心凸轮	KNIFE BAR DRIVING ECCENTRIC CAM	1
29		B02004	轴承	BALL BEARING	1
30		402S14006	螺钉	SCREW	6
30-1		409S14001	螺钉	SCREW	2
31		-----			0
32		402S14003	螺钉	SCREW	2
33		40225001	蜗杆	WORM	1
34		-----			0
35		4023503000	同步带轮组件	SHAFT SPROCKET	1
36		40235003	同步带	TIMING BELT	1
37		40224006	轴承	BEARING	1
38		-----	联轴器		1
38-1		40201063	联轴器传动块1	COUPLING 1	1
38-2		40201069	联轴器传动块2	COUPLING 2	1
38-3		40222040	减震橡胶	DAMPING RUBBER	1
39		40235027	手轮	HAND WHEEL	1
40		40230001	主轴电机	SERVO MOTOR	1
41		413S13012	电机安装螺钉	SCREW	4
42		40235028	绕线轮	BOBBIN WINDER DRIVING WHEEL	1
43		402S15006	绕线轮螺钉	SCREW	2
44		413S14001	螺钉	SCREW	6
45		207S14006	螺钉	SCREW	2
46		40228014	平垫片	WASHER	4
47		40128026	弹簧垫片	SPRING WASHER	4

3. 下轴关系/HOOK DRIVING SHAFT COMPONENTS

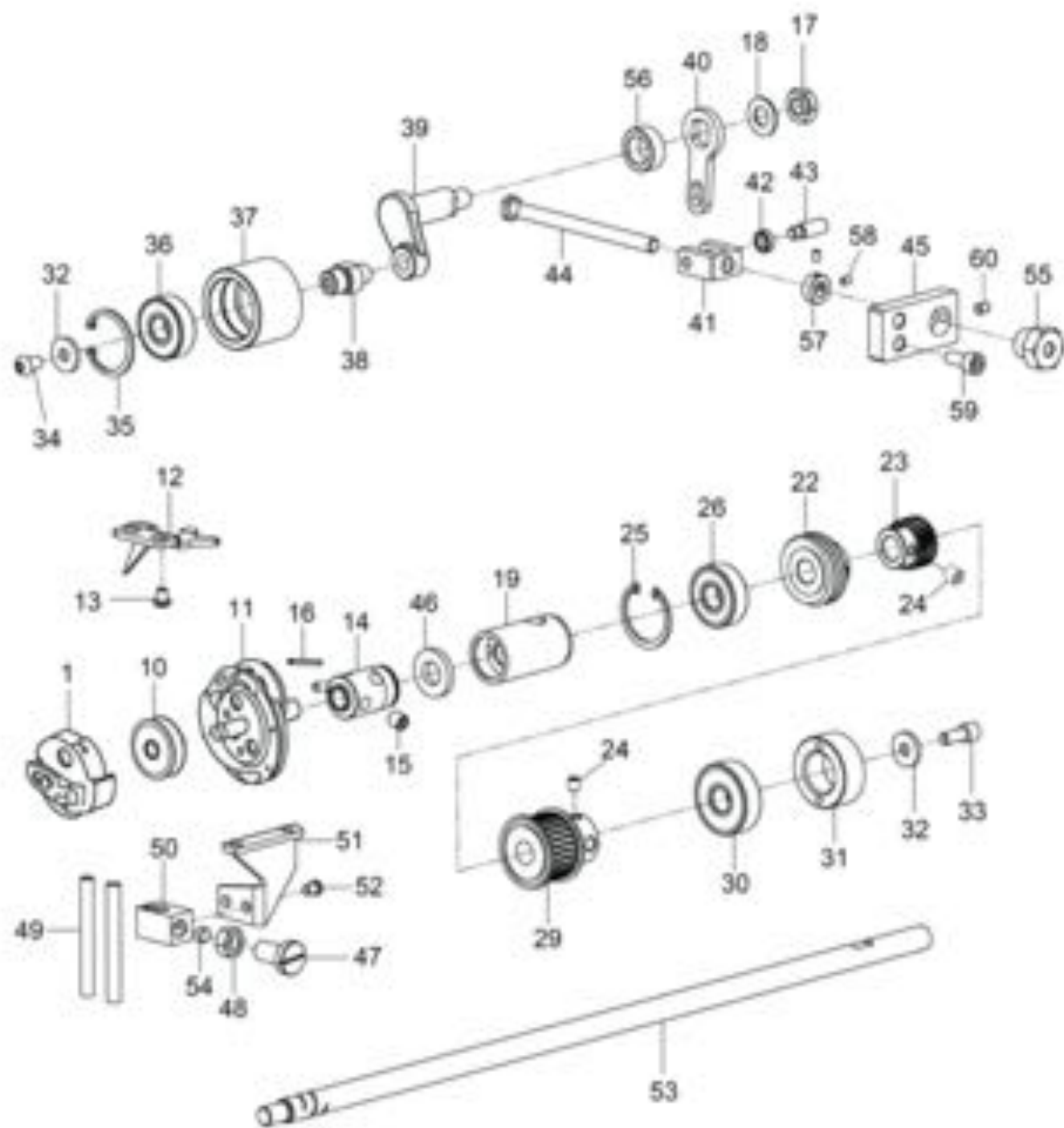

序号 NO.	注解 Note	件号 Part NO.	名称	Description	数量 Qty
1		4021800100	梭壳组件	BOBBIN CASE ASM.	1
10		4021800200	梭子	BOBBIN	1
11		4021800500	旋梭套组件	HOOK C ASM.	1
12		40212010	梭壳定位板	BOBBIN CASE POSITIONING PLATE	1
13		402S11006	螺钉	SCREW	2
14		4020300700	旋梭筒组件	OIL SLEEVE ASM.	1
15		413S14011	螺钉	SCREW	4
16		40123016	油线	OIL WICK	1
17		N01008	螺母	NUT	1
18		40228002	垫圈	THRUST WASHER	1
19		40203009	下轴前套	BUSHING ASM	1
20		12923018	油线	OIL WICK	2
21		-----			0
22		40225002	蜗杆	WORM LEVER	1
23		40225003	小齿轮	PINION	1
24		201S14002	螺钉	SCREW	6
25		H01009	挡圈	THRUST COLLAR	1
26		B04012	轴承	BALL BEARING	1
27		-----			0
28		-----			0
29		4023500700	小皮带链轮组件	BELT SPROCKET	1
30		40224004	轴承	BALL BEARING	1
31		40208001	轴承固定挡圈	COLLAR	1
32		20628006	垫圈	WASHER	1
33		402S13001	内六角平头螺钉	SCREW	1
34		S05038	螺钉	SCREW	1
35		H01009	挡圈	THRUST COLLAR	1
36		B04012	轴承	BALL BEARING	1
37		40235008	皮带张紧轮	TENSION PULLEY	1
38		40226005	调节杠杆针	ADJUSTING LEVER PIN	1
39		40205023	张紧轮连杆	TENSION PULLEY LINK	1
40		40212102	调节配件	ADJUSTING GUIDE	1
41		40204037	连接接头	CONNECTOR	1
42		40228031	垫片	SPACER	1
43		40226051	连接销	CONNECTION PIN	1
44		40205024	调节连杆	ADJUSTING LINK	1
45		40212103	固定板	FIXED PLATE	2
46		40223005	油毡	OIL FELT	2
47		402S30009	旋梭调节润滑螺钉	HOOK OIL ADJUSTING SCREW	1
48		402S16002	螺母	NUT	1
49		40221005	油管	OIL TUBE	0
50		400122	调节润滑螺钉座	OIL ADJUSTING SCREW BASE	1
51		40221004	调节润滑螺钉座架	OIL ADJUSTING SCREW BRACKET	1
52		402S11004	十字槽盘头螺钉	SCREW	2
53		40202039	下轴	HOOK DRIVING SHAFT	1
54		40226006	调节销	ADJUSTING PIN	1
55		402S16026	调节螺母	NUT	1
56		40208014	挡圈	THRUST COLLAR	1
57		41303002	挡圈	THRUST COLLAR	1
58		413S14004	螺钉	SCREW	2
59		S05004	固定板安装螺钉	SCREW	2
60		403S14017	螺钉	SCREW	1

4.压脚棒，送布板关系/PRESSER BAR, WORK CLAMP CARRIER COMPONENTS

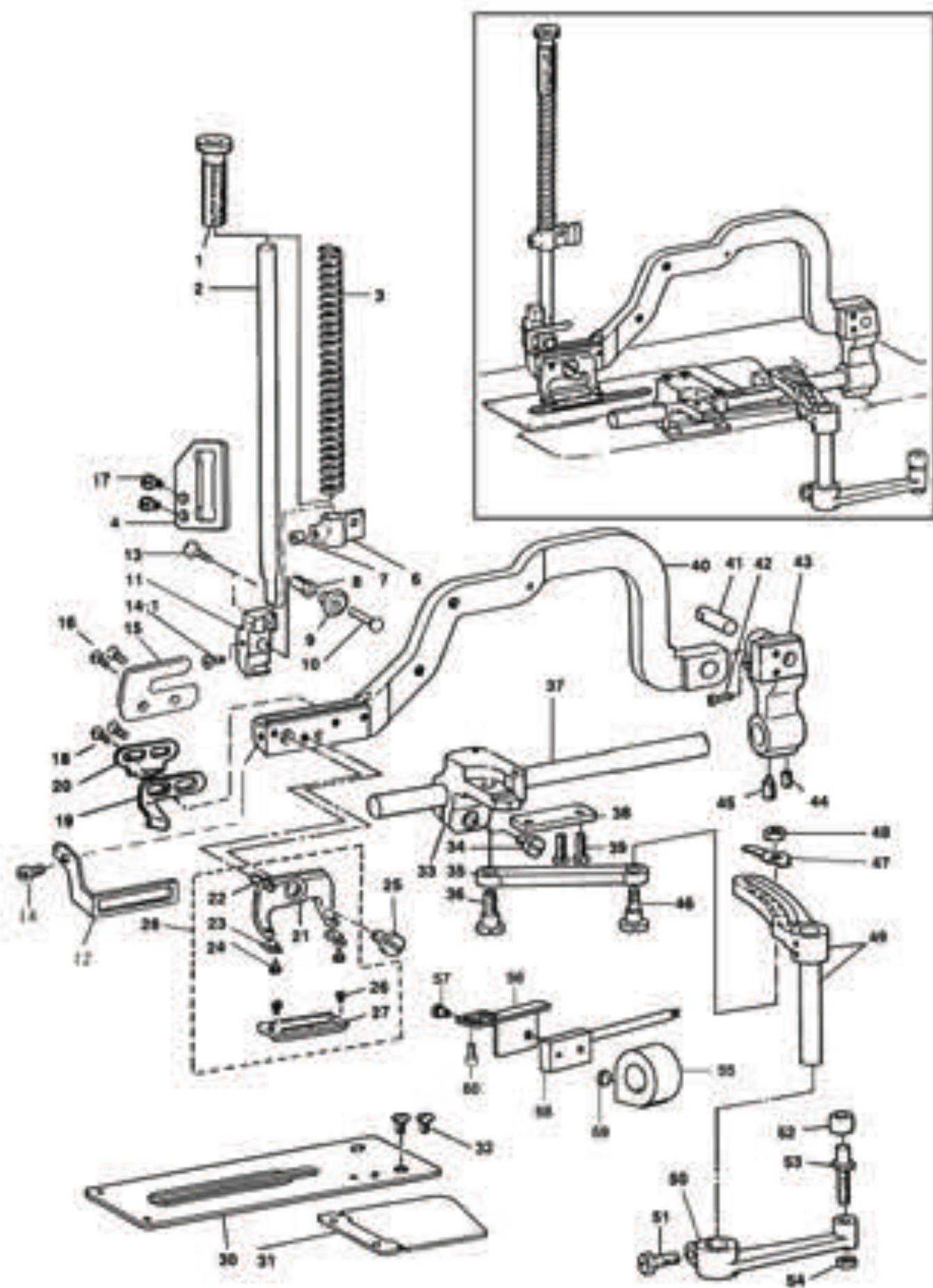

序号 NO.	注解 Note	件号 Part NO.	名称	Description	数量 Qty
1		402S30010	压簧调节手柄	PRESSER SPRING REGULATOR	1
2		40202004	压棒	PRESSER BAR	1
3		40227002	压簧	PRESSER SPRING	1
4		40212107	导向支架	GUIDE BRACKET	1
5		-----			
6		40209003	压棒定位架	PRESSER BAR POSITION BRACKET	1
7		409S14001	内六角平端紧定螺钉	SCREW	1
8		40203010	套管	COLLAR	1
9		40209004	滑动滚轮	SLIDE ROLLER	1
10		40226007	滑动滚轮销	CONNECTING PIN	1
11		40209005	支架	BRACKET	1
12		40212014	安全防护	SAFE DEFEND GUIDE	1
13		402S30011	压棒螺钉	SCREW	1
14		402S11030	螺钉	SCREW	1
14-1		402S11036	螺钉	SCREW	1
15		40212015	导向支架	GUIDE BRACKET	1
16		206S11002	螺钉	SCREW	2
17		206S11002	螺钉	SCREW	2
18		101S11020	螺钉	SCREW	2
19		40212016	面线剪断器导架	NEEDLETHREAD TRIMMER GUIDE	1
20		40212017	面线剪断器导架	NEEDLETHREAD TRIMMER GUIDE	1
21		40216001	压脚板座	WORK CLAMP CHECK HOLDER	1
22		40227003	压脚板座弹簧销	WORK CLAMP CHECK HOLDER SPRING	1
23		40212018	压脚弹簧板	WORK CLAMP CHECK SPRING	2
24		40226008	压脚弹簧定位销	WORK CLAMP CHECK SPRING SET PIN	2
25		402S20002	轴位螺钉	HINGE SCREW	1
26		101S11019	螺钉	SCREW	1
27		40216002	压脚板	WORK CLAMP CHECK	1
28		4021600300	压脚板座组件	WORK CLAMP CHECK HOLDER ASM.	1
29		-----			
30		40212019	送布拖板	STITCH PLATE	1
31		4021202000	支架盖板组件	BRACKET COVER	1
32		402S11007	螺钉	SCREW	2
33		40201004	送料支架	WORK CLAMP ARM BRACKET ASM.	1
34		401S12001	螺钉	SCREW	1
35		40205004	压脚臂支架	WORK CLAMP CARRIER BRACKET PITMAN	1
36		402S20003	轴位螺钉	HINGE SCREW	1
37		40202005	压脚臂滑杆	WORK CLAMP ARM SLIDE ROD	1
38		40212023	送布拖板支架导块	WORK CLAMP CARRIER BRACKET GUIDE	1
39		402S11028	螺钉	SCREW	2
40		40201033	布料夹支架	WORK CLAMP BRACKET	1
41		40226010	连接销	CONNECTING PIN	1
42		402S11009	螺钉	SCREW	1
43		40204031	拖架	BEARING ARM	1
44		402S14006	螺钉	SCREW	1
45		402S30016	螺钉	SCREW	1
46		402S30013	螺钉	SCREW	1
47		40212024	调节送料长度轴导板	LENGTH REGULATING SHAFT GUIDE	1
48		402S16003	螺母	NUT	1
49		4020400400	调节送料长度刻度盘组件	LENGTH REGULATING SCALE ASM.	1
50		40205005	送料臂	BELL CRANK	1
51		S05040	螺钉M6×16	SCREW	1
52		40209006	滚子	ROLLER	1
53		40226012	曲柄滚子销	BELL CRANK ROLLER STUD	1
54		402S16003	螺母	NUT	1
55		40201074	磁铁座	MAGNET BASE	1
56		40212118	传感器安装板	SENSOR MOUNTING PLATE	1
57		S01015	传感器安装螺钉	SENSOR MOUNTING SCREW	1
58		40230002	传感器	SENSOR	1
59		40230006	磁铁	MAGNET	1
60		413S13003	螺钉M4×6	SCREW	2

5. 针棒摇动台关系/NEEDLE BAR FRAME COMPONENTS

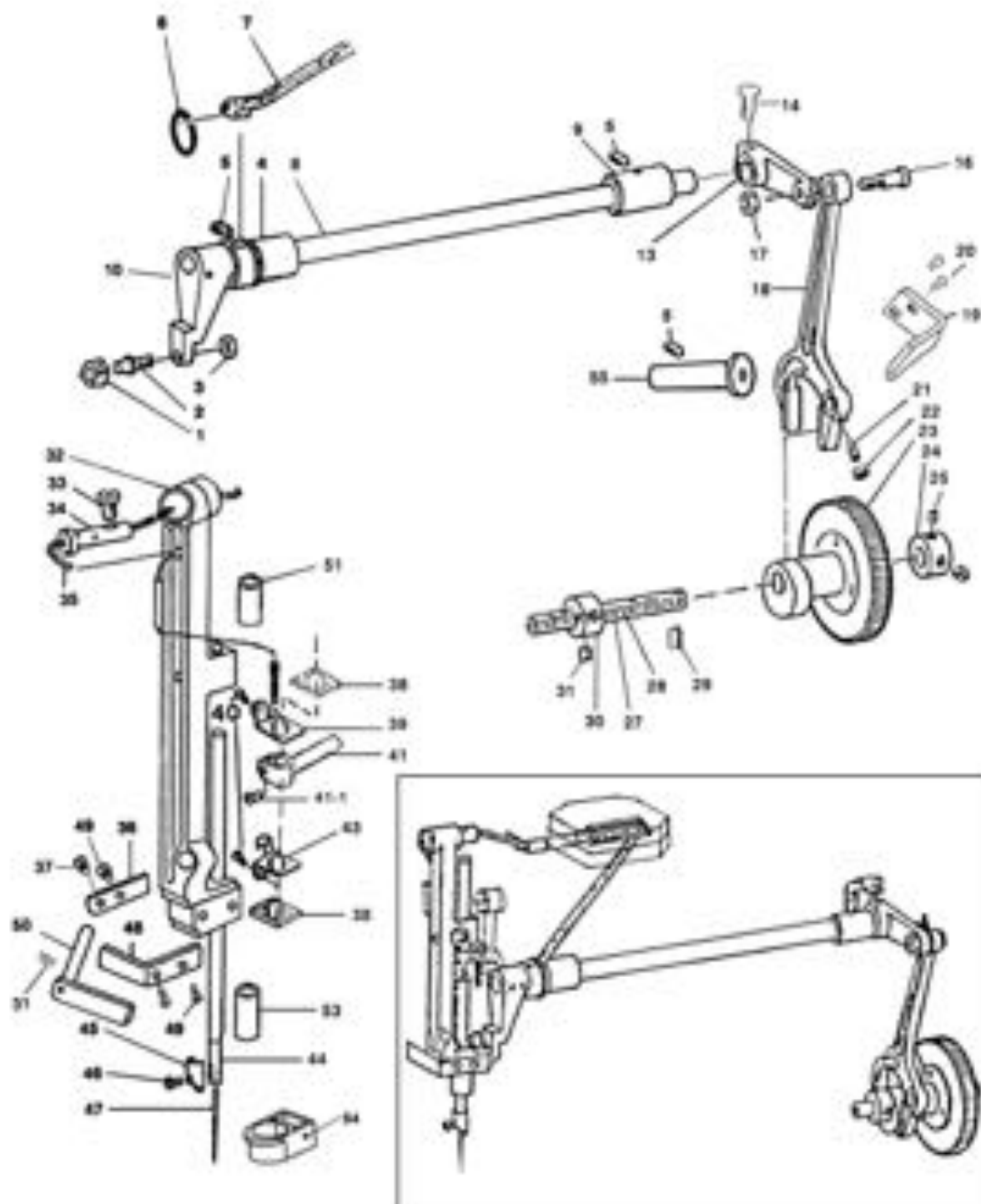

序号 NO.	注解 Note	件号 Part NO.	名称	Description	数量 Qty
1		400123	针杆架滑块	NEEDLE BAR CONNECTION SLIDE BLOCK	1
2		402S30014	滑块销螺钉	STUD	1
3		402S16003	螺母	NUT	1
4		40203011	摇杆后轴套	FRAME ROCK SHAFT BUSHING FRONT	1
5		402S14001	螺钉	SCREW	6
6		40222019	O形圈	RUBBER	1
7		40223023	油芯	OIL WICK	1
8		4020200700	摆杆轴组件	FRAME ROCK SHAFT	1
9		40204006	摇杆后轴衬	FRAME ROCK SHAFT BUSHING REAR	1
10		40203012	摆杆曲柄	FRAME ROCK SHAFT CRANK	1
13		40204007	摆杆后柄	FRAME ROCK SHAFT CRANK FRONT	1
14		402S13002	螺钉	SCREW	1
15		-----			0
16		402S20004	轴位螺钉	HINGE SCREW	1
17		402S16004	螺母	NUT	1
18		40204008	针杆摇杆	NEEDLE BAR PITMAN	1
19		400132	摆杆连接导板	ROCK SHAFT CONNECTION GUIDE	1
20		S05049	螺钉M4×14	SCREW	2
21		402S30015	螺钉	SCREW	1
22		402S16005	螺母	NUT	1
23		4022500400	针驱齿轮组件	NEEDLE DRIVING GEAR	1
24		40208002	挡圈	THRUST COLLAR	1
25		402S14006	螺钉	SCREW	2
26		-----			0
27		40203013	切刀驱动轴	CAM SHAFT	1
28		12923018	油线	OIL WICK	1
29		402S30016	螺钉	SCREW	1
30		40208003	挡圈	THRUST COLLAR	1
31		402S14006	螺钉	SCREW	1
32		4020100600	针杆架组件	NEEDLE BAR FRAME	1
33		402S14001	螺钉	SCREW	1
34		40226014	铰链销	HINGE STUD	1
35		12923018	油线	OIL WICK	1
36		40212027	左固定片	RETAINER LEFT	1
37		402S11010	螺钉	SCREW	2
38		40223009	油毡	FELT	2
39		40212028	油线高端固定板	OIL FELT RETAINER HIGH	1
40		402S11022	螺钉	SCREW	2
41		40205006	针杆连接杆	NEEDLE BAR CONNECTION	1
41-1		402S11010	螺钉	SCREW	1
42		-----			0
43		40212029	油线底端固定板	OIL FELT RETAINER LOWER	1
44		40202057	针杆	NEEDLE BAR	1
45		40213001	针杆导线架	NEEDLE BAR BOBBIN THREAD GUIDE	1
46		101S11006	螺钉	SCREW	1
47		40217002	机针12#	NEEDLE DP×5	5
48		40212030	右固定片	RETAINER RIGHT	1
49		402S11010	螺钉	SCREW	2
50		400124	固定导片	POSITION BRACKET	1
51		40203014	针杆套筒	NEEDLE BAR BUSHING	1
52		-----			0
53		40203015	针杆套筒	NEEDLE BAR BUSHING	1
54		40211005	油毡架	OIL FELT RETAINER	1
55		40226015	轴心	SHAFT	1
56		40223010	油毡	OIL FELT	1

6. 针摆幅调节关系/OVEREDGING WIDTH ADJUSTING COMPONENTS

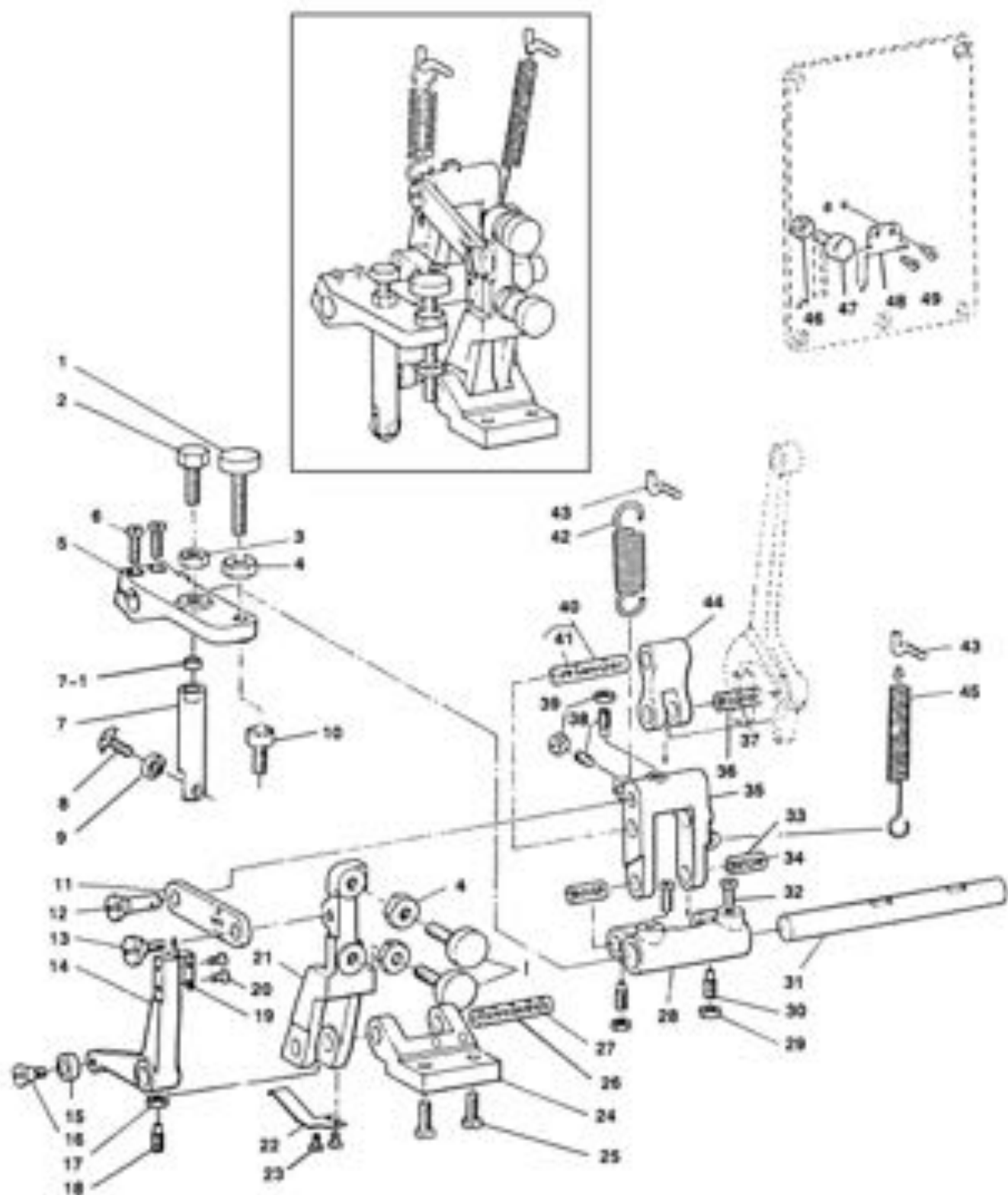

序号 NO.	注解 Note	件号 Part NO.	名称	Description	数量 Qty
1		402S30017	线迹宽度调节螺钉	STITCH WIDTH REGULATING SCREW	3
2		402S11034	螺钉	SCREW	1
3		402S16006	螺母	NUT	1
4		N01008	螺母M8	NUT	3
5		40201008	复位杆	REPOSITIONING LEVER	1
6		101S11021	螺钉	SCREW	2
7		40202010	离合杆	TRIPPING ROD	1
7-1		40211006	止动橡皮	STOP RUBBER	1
8		402S30018	螺钉M5×8	SCREW	1
9		B04013	轴承605Z	BALL BEARING	1
10		402S30019	调节杆螺钉	REGULATING LEVER STOPPER	1
11		40205007	调节杆连接板	REGULATING LEVER COBBECTION	1
12		40226016	调节销	REGULATING HINGE PIN	1
13		402S20005	轴位螺钉	HINGE SCREW	1
14		40204009	指示曲柄	BELL CRANK	1
15		40209008	滚轮	ROLLER	1
16		402S20006	轴位螺钉	HINGE SCREW	1
17		402S16005	螺母	NUT	1
18		402S30015	螺钉	SCREW	1
19		40212031	刻度指示针	BARRED WIDTH INDICATOR	1
20		101S11006	螺钉	SCREW	2
21		40201009	调节叉杆	REGULATING LEVER	1
22		40227004	弹簧板	SPRING	1
23		101S11006	螺钉	SCREW	2
24		40204038	调节叉杆座	REGULATING LEVER BRACKET	1
25		401S13001	螺钉	SCREW	2
26		40202011	调节杆轴	REGULATING LEVER SHAFT	1
27		12923018	油线	OIL WICK	1
28		40204011	轴承座	BEARING BRACKET	1
29		402S16005	螺母	NUT	2
30		402S30015	紧定螺钉	SCREW	2
31		40202012	针摆复位轴	NEEDLE THROW REPOSITIONING SHAFT	1
32		402S11012	螺钉	SCREW	2
33		40226017	连接销	BEARING BRACKET	2
34		12923018	油线	OIL WICK	2
35		40204012	叉形连杆	REPOSITIONING LEVER LINK	1
36		40226018	连接销	CONNECTING FORKED LINK PIN	1
37		12923018	油线	OIL WICK	1
38		402S30015	螺钉	SCREW	2
39		402S16005	螺母	NUT	2
40		40226019	连接销	CONNECTING STUD	1
41		12923018	油线	OIL WICK	1
42		40227005	弹簧	SPRING	1
43		402S30021	悬挂螺钉	SUSPENSION SCREW	2
44		40204013	叉形连杆	CONNECTING FORKED LINK	1
45		40227006	拉簧	SPRING	1
46		402S16003	螺母	NUT	1
47		402S30019	调节限位螺钉	REGULATING LEVER STOPPER	1
48		40212032	缝宽指示针	SEAM WIDTH INDICATOR	1
49		101S11006	螺钉	SCREW	2

7.上线剪刀关系/NEEDLE THREAD TRIMMER COMPONENTS

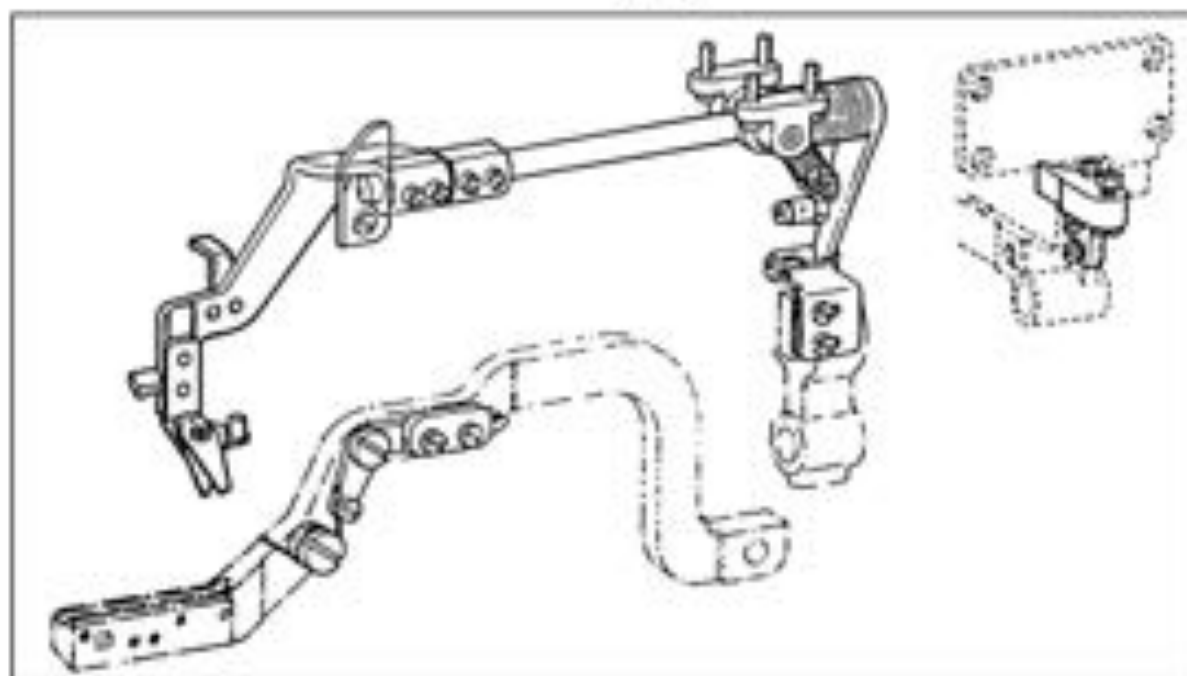
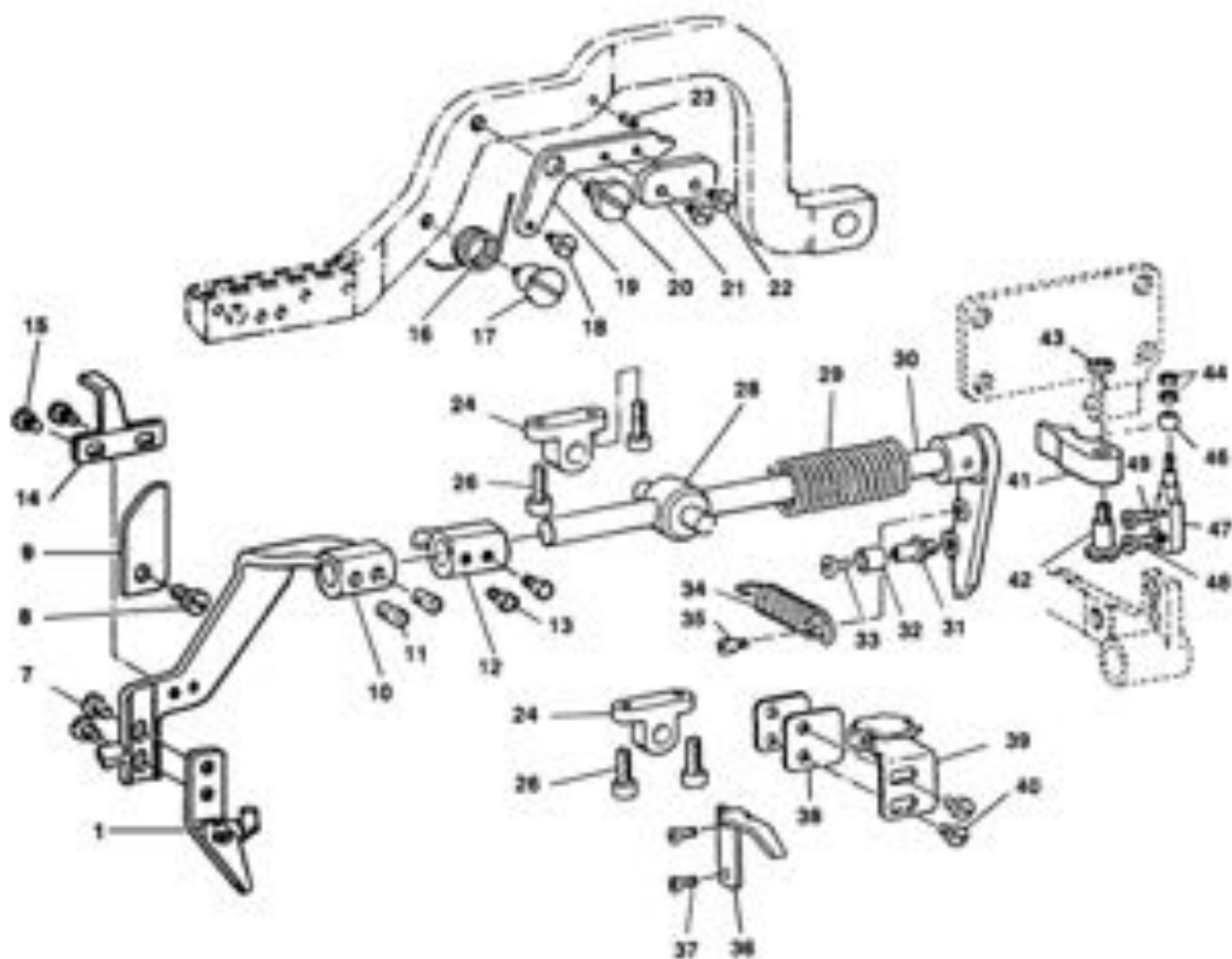

序号 NO.	注解 Note	件号 Part NO.	名称	Description	数量 Qty
1		4021900100	面线剪刀组件	NEEDLE THREAD TRIMMER ASM.	1
7		402S11006	螺钉	SCREW	2
8		402S11013	螺钉	SCREW	1
9		40212033	面线器轴导板	NEEDLE THREAD TRIMMER SHAFT GUIDE	1
10		40212094	保持架组件	THREAD TRIMMER	1
11		409S14001	螺钉	SCREW	2
12		4020301600	微调保持组件	THREAD TRIMMER HOLDER	1
13		409S14001	螺钉	SCREW	2
14		40212036	限位板	LIMITING PLATE	1
15		402S11036	螺钉	SCREW	2
16		40227008	转距弹簧	DRIVING CAM SPRING	1
17		402S20008	传动凸轮转矩弹簧轴	DRIVING CAM SPRING AXLE	1
18		402S20009	轴位螺钉	HINGE SCREW	1
19		40212037	传动凸轮安装板	DRIVING CAM INSTALLING PLATE	1
20		402S20010	轴位螺钉	HINGE SCREW	1
21		40212038	传动凸轮板	DRIVING CAM	1
22		402S11014	螺钉	SCREW	2
23		P03029	销3×10	SPRING PIN	1
24		40201010	支架	BRACKET	2
25		-----			0
26		402S13001	螺钉	SCREW	4
27		-----			0
28		40226022	万向接头	UNIVERSAL JOINT	1
29		40227009	弹簧	SPRING	1
30		4020203500	面线切刀轴组件	NEEDLE THREAD TRIMMER SHAFT	1
31		40226023	滚轮销	STUD	1
32		40209029	滚子	CAM ROLL	1
33		402S11015	螺钉	SCREW	1
34		40227010	切刀弹簧	SPRING	1
35		402S30022	悬挂螺钉	NEEDLE THREAD TRIMMER SHAFT	1
36		40212039	压脚臂锁	LATCH PRESSER ARM	1
37		402S11014	螺钉	SCREW	2
38		40212040	垫片	SPACER	2
39		4021204100	锁架组件	LOCKING BRACKET LATCH	1
40		402S11006	螺钉	SCREW	2
41		40209010	剪线轴顶块	THREAD TRIMMING SHAFT SEGMENT	1
42		402S20011	轴位螺钉	HINGE SCREW	1
43		402S16005	螺母	NUT	1
44		402S16007	螺母	NUT	2
45		-----			
46		40209011	滚柱	ROLLER	1
47		40204015	嵌件	STUD	1
48		409S11008	螺钉	SCREW	2
49		40228008	垫片	WASHER	1

8. 下线剪刀关系/BOBBIN THREAD TRIMMER COMPONENTS

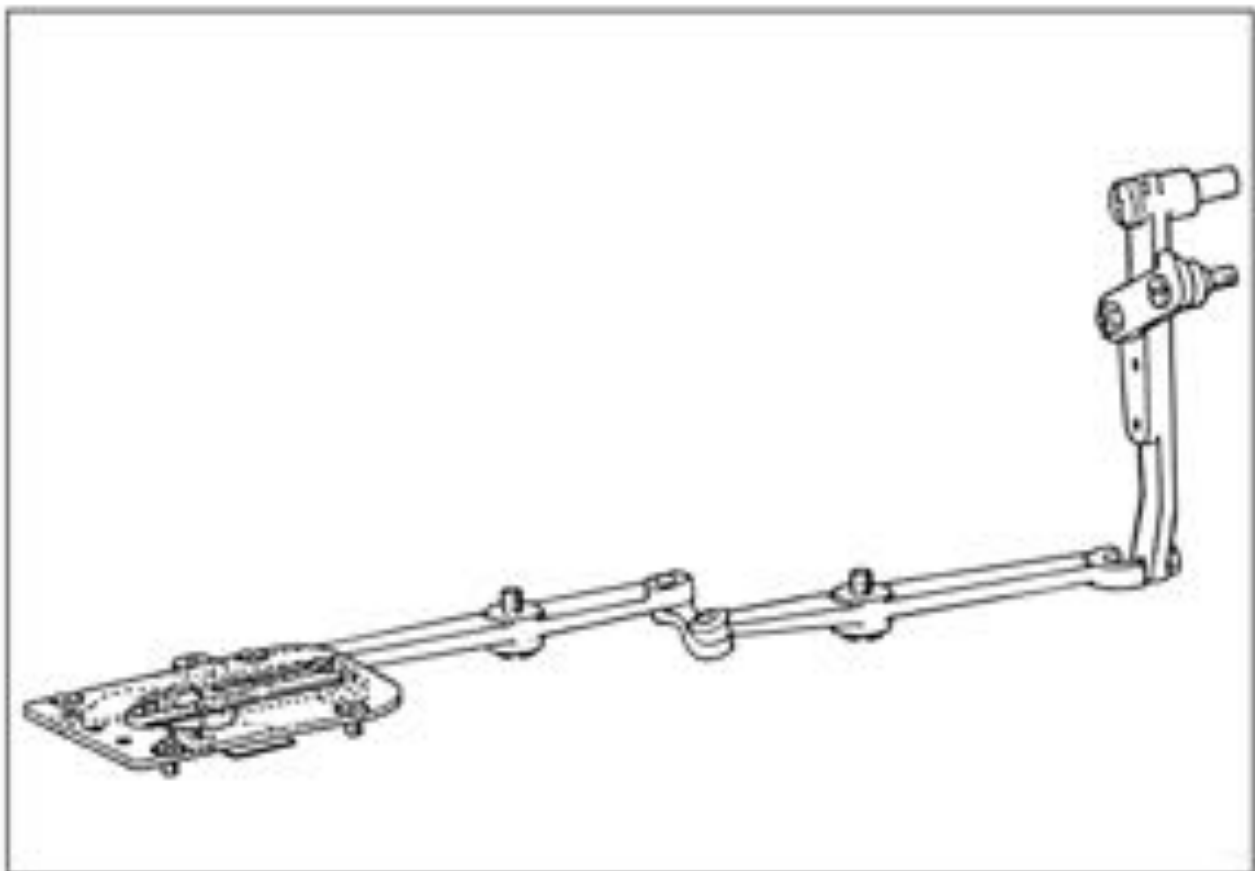
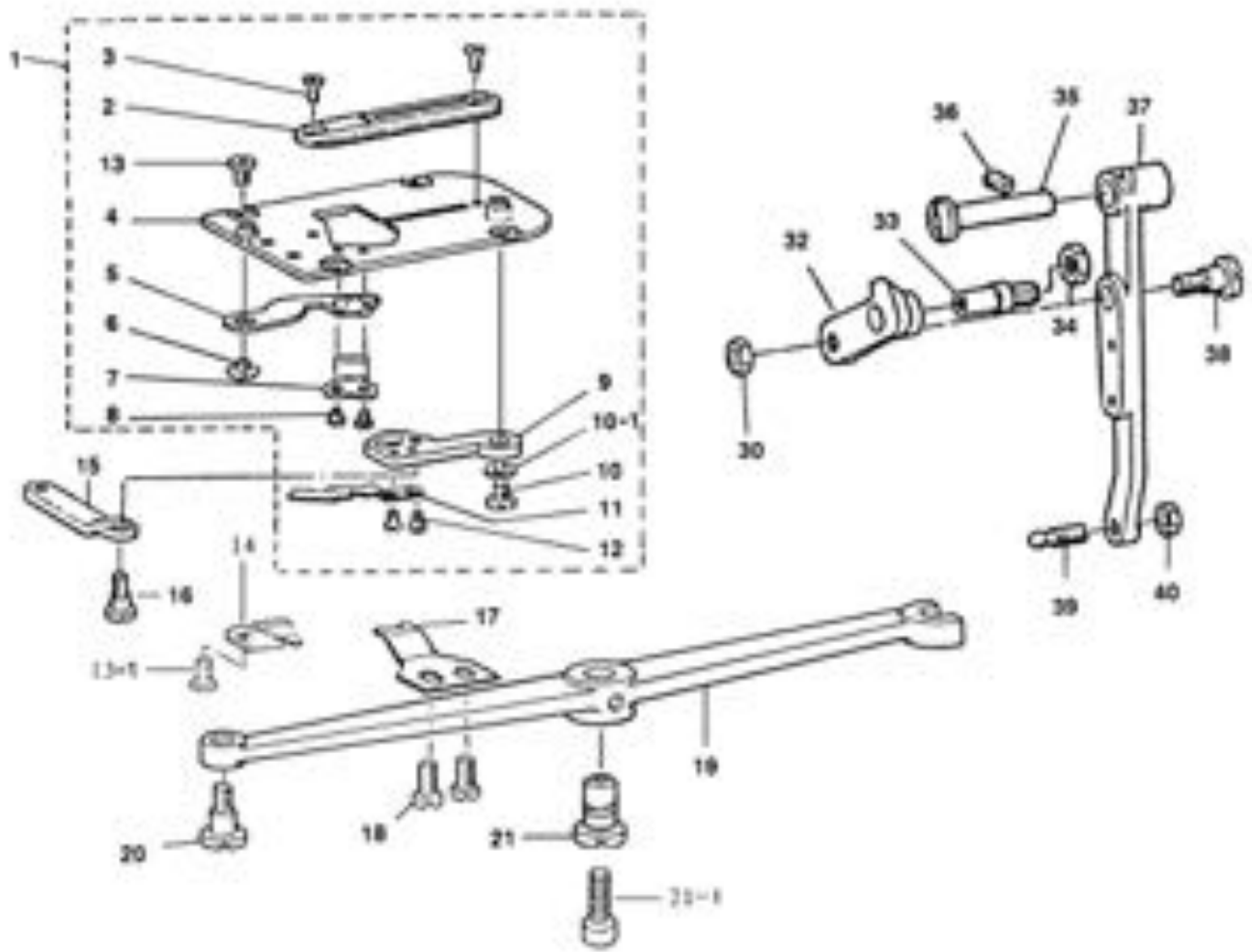

序号 NO.	注解 Note	件号 Part NO.	名称	Description	数量 Qty
1		4021500100	剪底线器组件	BOBBIN THREAD TRIMMER ASM.	1
2		40215002	针板组件	NEEDLE PLATE	1
3		402S17001	螺钉	SCREW	2
4		4021500300	针板座组件	THROAT PLATE BASE	1
5		4021900500	剪底线动刀	BOBBIN THREAD TRIMMER	1
6		402S30023	螺钉	SCREW	1
7		40219007	底线切刀固定刀	COUNTER KNIFE	1
8		402S11016	螺钉	SCREW	2
9		40204016	底线切刀杆	BOBBIN THREAD TRIMMER LEVER	1
10		402S11017	螺钉	SCREW	1
10-1		40228009	垫圈	WASHER	1
11		40219008	底线拉杆	BOBBIN THREAD PULLER	1
12		402S11018	螺钉	SCREW	2
13		402S11030	螺钉	SCREW	4
13-1		402S11036	螺钉	SCREW	1
14		40227012	压板	PRESSER PLATE	1
15		40212044	剪底线连杆	BOBBIN THREAD TRIMMER LINK	1
16		402S20012	铰链螺钉	SCREW	1
17		40227013	底线导向板	BOBBIN THREAD GUIDE	1
18		402S11022	螺钉	SCREW	2
19		40205008	剪底线传动杆	BOBBIN THREAD TRIMMER DRIVING LEVI	1
20		402S20013	螺钉	HINGE SCREW	1
21		40210004	套筒	SLEEVE	1
21-1		S05042	螺钉	SCREW	1
22		-----	剪线底传动杆		0
23		-----	套筒		0
24		-----	铰链销螺钉杆套筒		0
25		-----	剪底线传动杆		0
26		-----	套 筒		0
27		-----	螺钉		0
28		-----	剪底线传动杆连杆		0
29		-----	螺钉		0
30		402S16003	螺母	NUT	1
31		-----			0
32		40205019	凸轮连杆	CONNECTING LINK	1
33		402S30058	止动限位螺钉	STOP SCREW	1
34		402S16008	螺母	NUT	1
35		40226026	铰链螺栓	HINGE STUD	1
36		402S14001	内六角凹端紧定螺钉	SCREW	1
37		40205010	底线剪刀驱动杆	BOBBIN THREAD TRIMMER DRIVING ARM	1
38		402S20014	轴位螺钉	HINGE SCREW	1
39		402S30025	球形螺钉	BALL SCREW	1
40		402S16003	螺母	NUT	1

9. 刀棒关系 / KNIFE BAR COMPONENTS

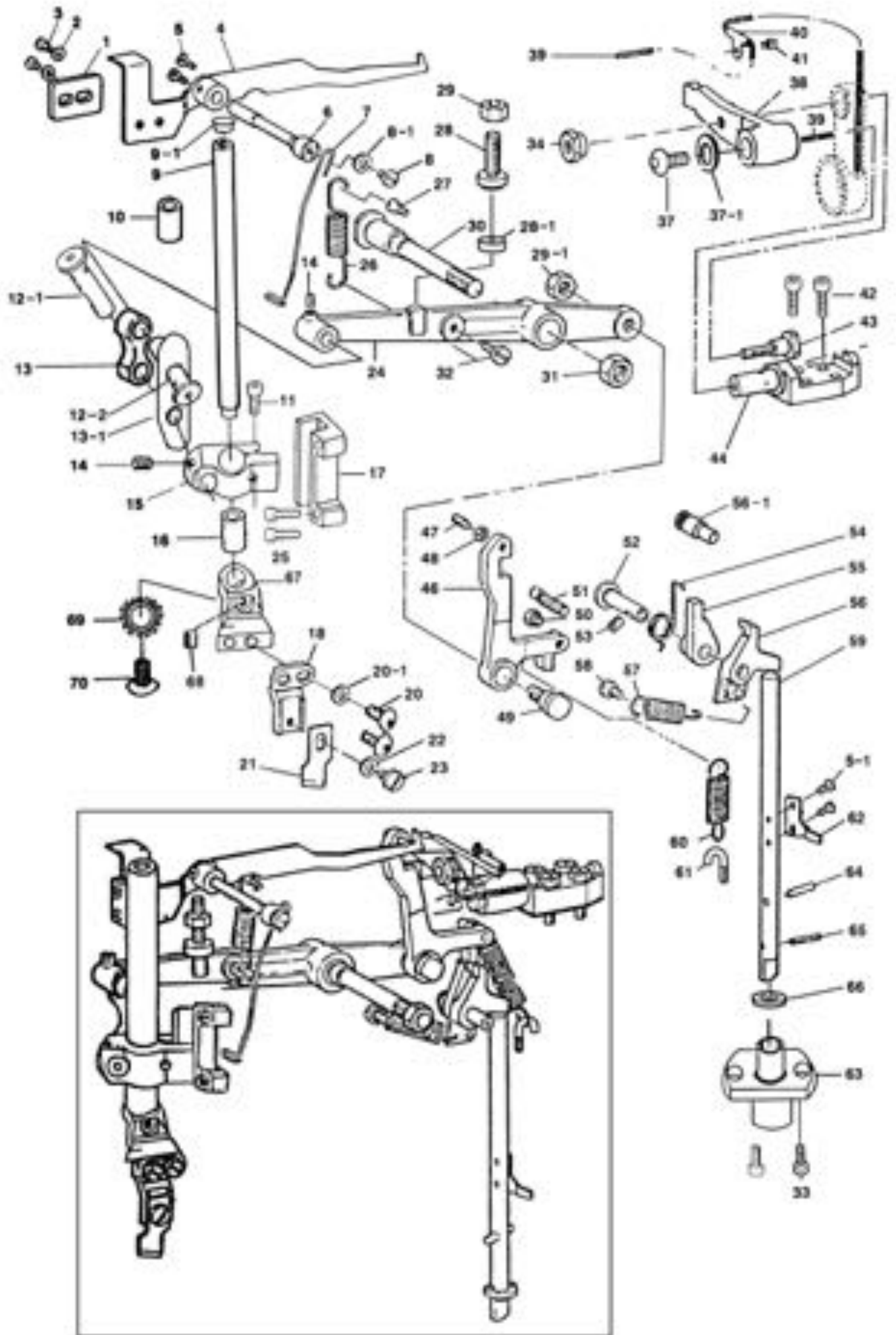

序号 No.	注解 Note	序号 Part No.	名称	Description	数量 Qty
1		40212043	刀片杆架平面垫	KNIFE STOP LEVER BRACKET	1
2		40229009	垫片	WASHER	1
3		402511036	螺钉	SCREW	2
4		4021204900	刀片杆架零件	KNIFE STOP LEVER	1
5		402511036	螺钉	SCREW	2
5-1		2000110002	螺母	NUT	2
6		40200915	刀片杆架铰链螺栓	KNIFE STOP LEVER HINGE STUD	1
7		402130002	线钩脚螺栓	THREAD CHECK WIRE	1
8		402511003	螺钉	SCREW	1
8-1		W4117	垫片	SPACER	1
9		40202916	刀片	KNIFE BAR	1
9-1		40229029	橡皮塞	RUBBER PLUG	1
10		40203021	刀片齿圈	KNIFE BAR BUSHING	1
11		402513009	螺钉	SCREW	1
12-1		40200027	连杆销	CONNECTING LINK PIN	1
12-2		40229028	连杆销	CONNECTING LINK PIN	1
13		40200011	刀片连杆	KNIFE BAR CONNECTING LINK	1
13-1		40229021	垫片	SPACER	1
14		402530002	螺钉	SCREW	2
15		40201011	刀片定位架	KNIFE BAR POSITION BRACKET	1
16		40203022	齿圈	KNIFE BAR BUSHING	1
17		40209027	刀片导引	KNIFE BAR GUIDE	1
18		40209013	刀架定架	KNIFE HOLDER	1
19		-----	-----	-----	0
20		402513005	螺钉	SCREW	2
20-1		40229018	垫片	WASHER	2
21		40219009	刀片1/2"	KNIFE 1/2"	1
22		40229019	垫片	WASHER	1
23		402511020	螺钉	SCREW	1
24		40201012	刀片传动杆	KNIFE BAR DRIVING LEVER	1
25		505017	螺母	NUT	2
26		40227014	拉簧	SPRING	1
27		402530026	铰链销螺钉	HINGE SCREW	1
28		402530027	螺钉	ADJUSTING SCREW	1
28-1		40229022	止动垫	SPACER	1
29		402516002	螺母	NUT	1
29-1		402516021	螺母	NUT	1
30		40202946	刀片传动杆轴	KNIFE BAR DRIVING LEVER SHAFT	1
31		402516009	螺母	NUT	1
32		402520010	铰链螺钉	HINGE SCREW	1
33		505049	螺母	NUT	2
34		402516010	刀片传动曲柄螺母	KNIFE BAR DRIVING CRANK NUT	1
37		402511003	螺钉	SCREW	1
37-1		40229011	垫片	SPACER	1
38		40204017	刀片传动曲柄	KNIFE BAR DRIVING CRANK	1
39		12023018	油线	OIL WICK	1
40		40212029	油线支架	OIL WICK HOLDER	1
41		402511004	螺钉	SCREW	1
42		505025	螺钉M6×18	SCREW	2
43		402520019	铰链螺钉	HINGE SCREW	1
44		40204019	刀片传动曲柄轴	KNIFE BAR DRIVING CRANK SHAFT	1
46		40201013	刀片传动杆	KNIFE BAR DRIVING LEVER BELL CRANK	1
47		402530029	螺钉	SCREW	1
48		402516000	螺母	NUT	1
49		402520017	铰链螺钉	HINGE SCREW	1
50		402516011	螺母	NUT	1
51		40229029	轴心销	PIN	1
52		40229030	铰链螺栓	HINGE STUD	1
53		402516001	螺母	NUT	1
54		40227013	拉簧	TENSION SPRING	1
55		40210000	轴承壳(B)	BEARING PART (B)	1
56		40210006	轴承壳(A)	BEARING PART (A)	1
56-1		402530029	铰链销螺钉	SCREW	1
57		40227016	拉簧	TENSION SPRING	1
58		402520019	铰链螺钉	HINGE SCREW	1
59		40202918	传动杆	DRIVING ROD	1
60		40227017	拉簧	TENSION SPRING	1
61		402530030	铰链螺钉	SUSPENSION SCREW	1
62		40212048	铰链架	FINGER	1
63		40203023	传动杆定位架	DRIVING ROD POSITION BRACKET	1
64		PS1908	销3×18	POSITION PIN	1
65		PS3030	销3×18	SPRING PIN	1
66		40229023	止动垫圈	THROST WASHER	1
67		40209014	刀架固定架	KNIFE HOLDER POSITION BRACKET	1
68		402516006	螺母	NUT	2
69		-----	-----	-----	0
70		402530021	螺钉	SCREW	1

10. 送布凸轮关系/FEED CAM & TRIPPING SEGMENT COMPONENTS

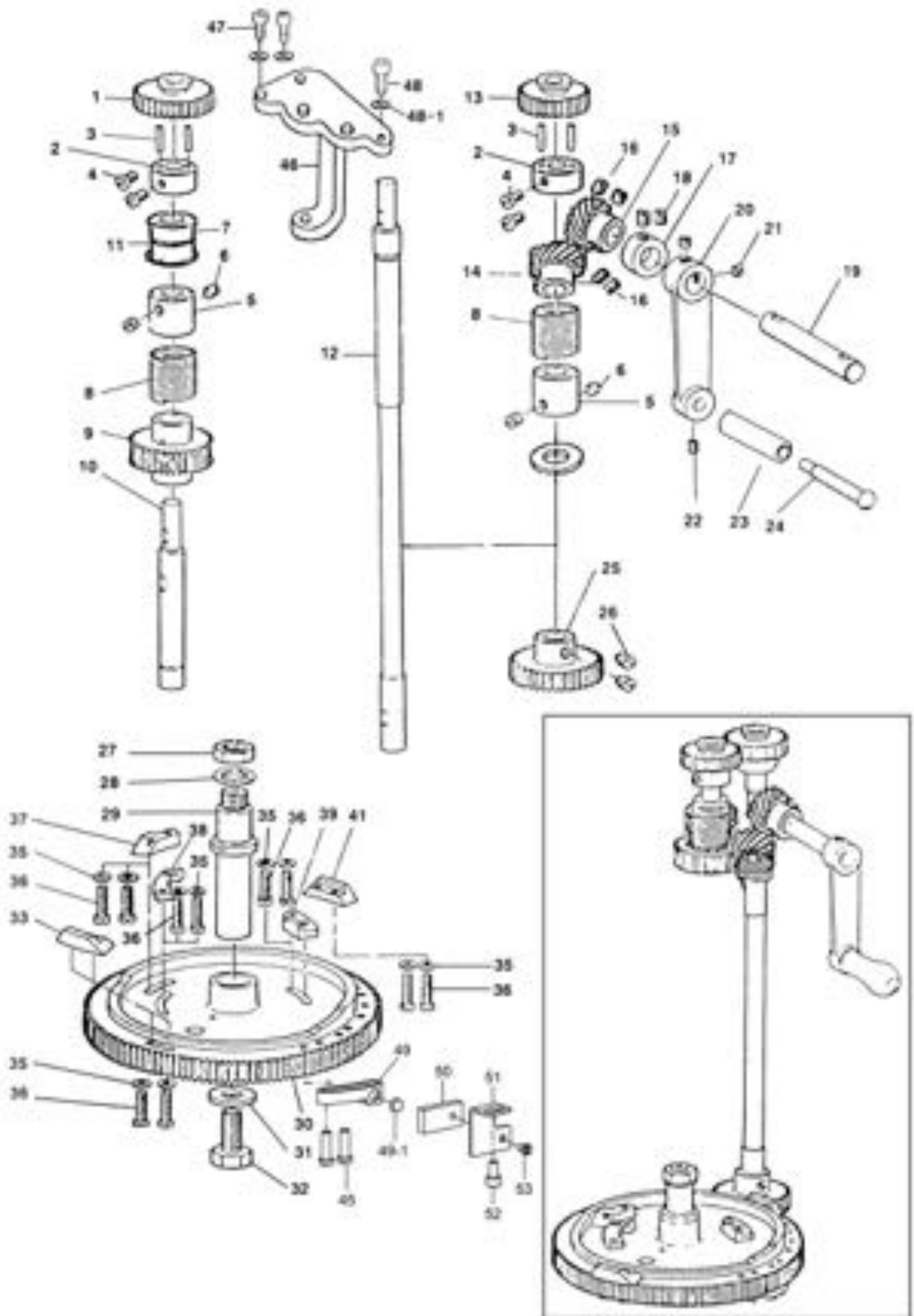

序号 NO.	注解 Note	件号 Part NO.	名称	Description	数量 Qty
1		40225006	直齿轮	SPUR GEAR	1
2		4020800400	正齿轮轴套组件	SPUR GEAR BUSHING	2
3		40226031	正齿轮定位销	SPUR GEAR BUSHING PIN	4
4		402S14006	螺钉	SCREW	4
5		40203024	离合器	CLUTCH COLLAR	2
6		402S14006	螺钉	SCREW	4
7		40203025	固定套管	POSITION BUSHING	1
8		40227018	离合器弹簧	CLUTCH SPRING	2
9		40225007	传动蜗轮	FEED CAM DRIVING WORM WHEEL	1
10		40202019	传动蜗轮轴	FEED CAM DRIVING WORM WHEEL SHAFT	1
11		40223016	油毡	COLLAR	1
12		40202020	送布凸轮传动蜗轮轴	FEED CAM DRIVING SHAFT	1
13		40225008	直齿轮	SPUR GEAR	1
14		40225009	手摇曲柄左齿轮	HANDLE CRANK BEVEL GEAR LEFT	1
15		40225010	手摇曲柄右齿轮	HANDLE CRANK BEVEL GEAR RIGHT	1
16		S09002	螺钉	SCREW	2
17		40208006	挡圈	THRUST COLLAR	1
18		402S14006	螺钉	SCREW	2
19		40202021	手摇曲柄轴	HANDLE CRANK SHAFT	1
20		40204019	手摇曲柄	HANDLE CRANK	1
21		402S14006	螺钉	SCREW	2
22		402S15002	螺钉	SCREW	1
23		40211007	手柄	HANDLE SHAFT	1
24		40202022	手柄轴	HANDLE SHAFT	1
25		40225011	送布凸轮传动齿轮	FEED CAM DRIVING GEAR	1
26		409S14001	螺钉M6×6	SCREW	2
27		N01010	螺母M12	NUT	1
28		40228012	垫片	THRUST WASHER	1
29		40202023	送布凸轮轴	FEED CAM SHAFT	1
30		40210007	送布凸轮	FEED CAM	1
31		40228013	垫片	WASHER	1
32		402S11027	螺钉	SCREW	1
33		40209015	加固离合块	BAR TRIPPING SEGMENT	1
34		-----			0
35		40228008	垫片	WASHER	6
36		402S11001	螺钉	SCREW	6
37		40209016	切刀离合块	KNIFE TRIPPING SEGMENT	1
38		40212049	松线离合块	TENSION RELEASE TRIPPING SEGMENT	1
39		40212050	松线离合块	TENSION RELEASE TRIPPING SEGMENT	1
40		-----			0
41		40209015	加固离合块	BAR TRIPPING SEGMENT	1
42		-----			0
45		402S11031	螺钉	SCREW	8
46		40209020	齿轮定位架	GEAR POSITION BRACKET	1
47		S05031	螺钉	SCREW	2
48		S05031	螺钉	SCREW	1
48-1		40228017	垫片	SPACER	3
49		40209038	低速感应块		1
49-1		40230006	磁铁	MAGNET	1
50		40230002	传感器	SENSOR	1
51		40212119	传感器安装板	SENSOR FITTING PLATE	1
52		413S13016	螺钉	SCREW	1
53		S01015	传感器安装螺钉	SCREW	1

11、电控关系/CONTROL BOX COMPONENTS

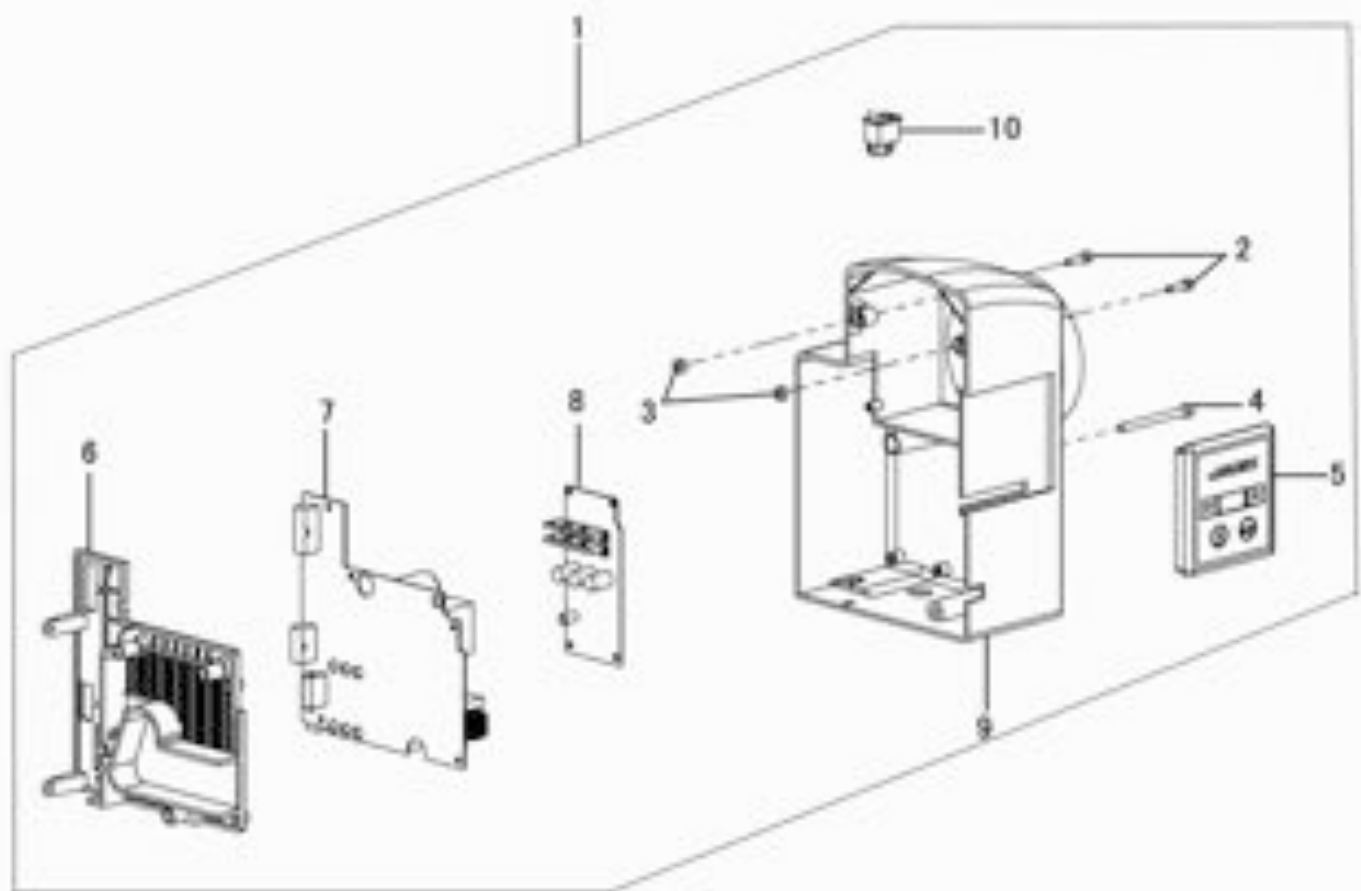

序号 NO.	注解 Note	件号 Part NO.	名称	Description	数量 Qty
1		40230013	电控组件	CONTROL BOX ASM	1
2		413S13020	螺钉 M4×16	SCREW	2
3		40222039	橡胶垫圈	RUBBER WASHER	2
4		S05035	螺钉 M5×25	SCREW	3
5		40230008	操作屏	OPERATION PANEL	1
6		40211025	电控箱盖	CONTROL BOX COVER	1
7		40230010	电路板 A	PCB A	1
8		40230011	电路板 B	PCB B	1
9		40230012	电控箱	CONTROL BOX	1
10		40230013	开关	SWITCH	1

12、安全保护关系/SAFE PROTECTION COMPONENTS

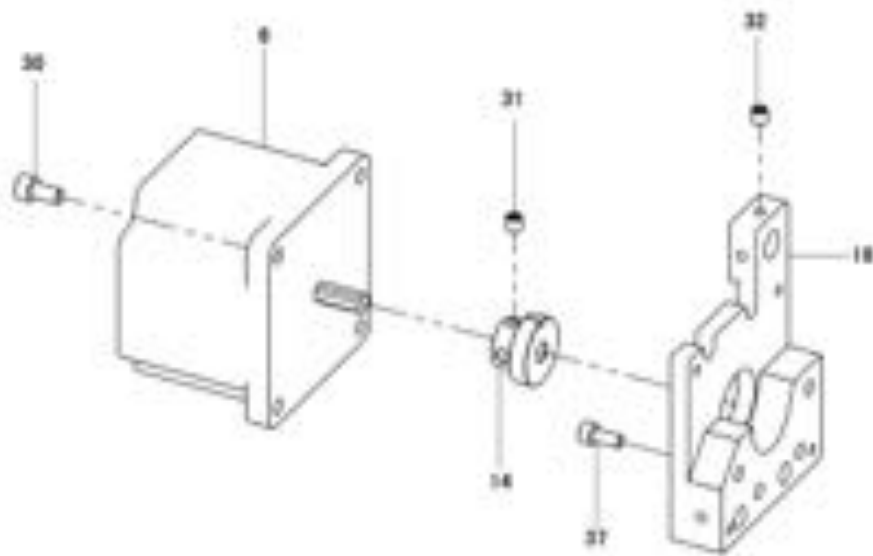
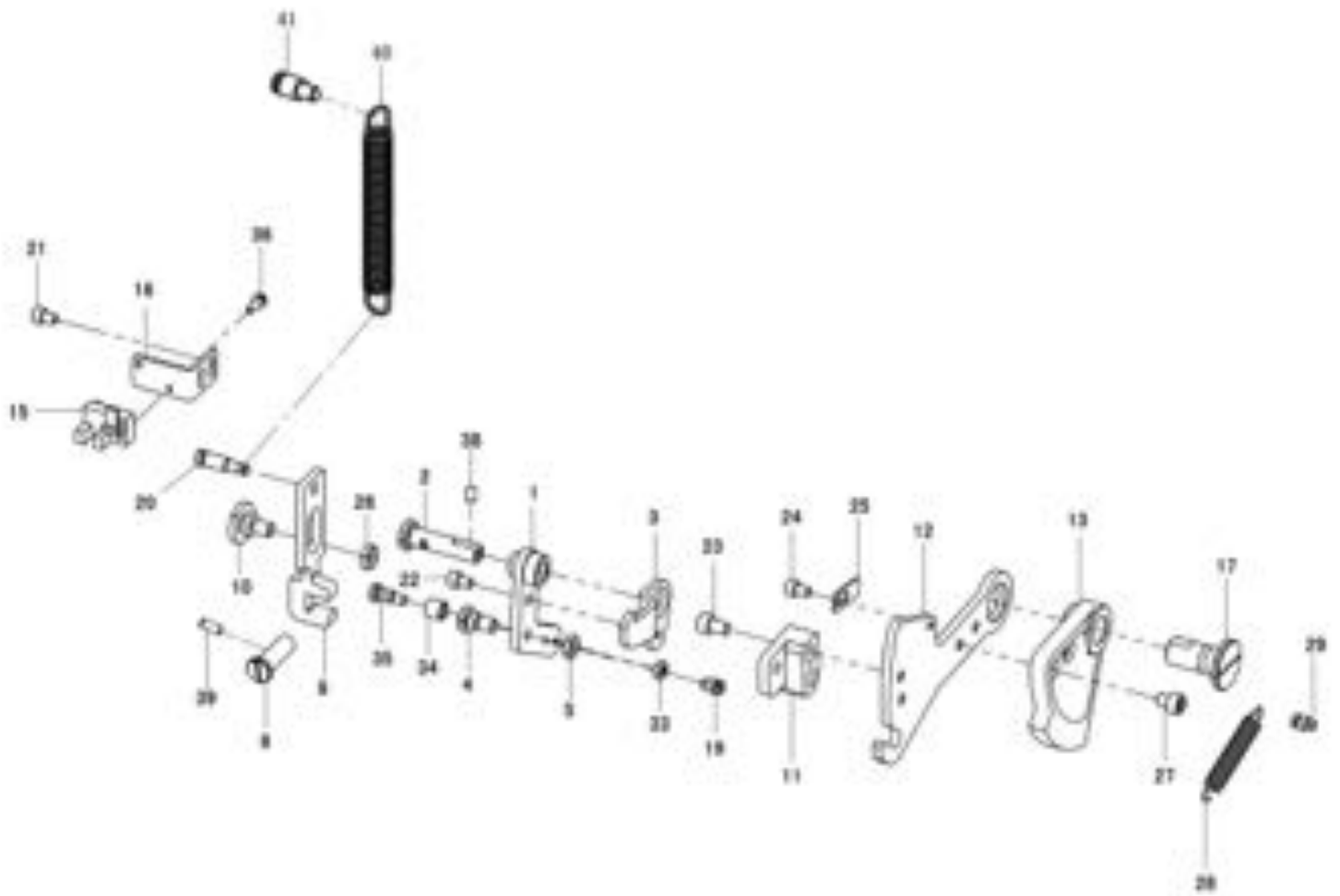

序号 NO.	注解 Note	件号 Part NO.	名称	Description	数量 Qty
1		4021212400	启动架组件	STARTING MATERIAL	1
2		40226053	铰链螺栓	HINGE BOLT	1
3		40212121	安全底座	SECURITY BASE	1
4		40210008	轴位螺钉	HINGE SCREW	1
5		402S16003	螺母	NUT	2
6		40230008	步进电机	STEPPING MOTOR	1
7		-----			
8		402S30061	滚子连接销	ROLLER CONNECTING PIN	1
9		40201071	压板	PRESSING PLATE	1
10		402S20037	轴位螺钉	HINGE SCREW	1
11		40209049	压板座	CLAMP HOLDER	1
12		40212112	机械锁启动板	MECHANICAL LOCK START	1
13		40225019	从动齿轮	FOLLOWER GEAR	1
14		40225020	主动齿轮	DRIVE GEAR	1
15		40330010	传感器	SENSOR	1
16		40212113	传感器安装板	SENSOR MOUNTING PANEL	1
17		40226052	连接销	CONNECTING LINK PIN	1
18		40201072	电机安装座	MOTOR MOUNTING	1
19		413S30016	螺钉	SCREW	1
20		413S30013	挂簧螺钉	SCREW	1
21		413S13003	螺钉M4×6	SCREW	2
22		402S13010	螺钉M5×8	SCREW	2
23		413S13019	螺钉M5×10	SCREW	2
24		413S13003	螺钉M4×6	SCREW	1
25		41312096	传感器检测板	SENSOR	1
26		402S16004	螺母	NUT	2
27		413S13010	螺钉M5×8	SCREW	2
28		41327012	弹簧	PRESSERSPRING	1
29		413S30016	挂簧螺钉	SCREW	1
30		S05124	螺钉M5×16	SCREW	4
31		413S14001	螺钉M6×6	SCREW	1
32		207S14006	螺钉M5×5	SCREW	1
33		413S16003	螺母M4	NUT	1
34		41303024	滚柱	PIN ROLLER	1
35		413S30015	滚子连接螺钉	SCREW	1
36		413S13026	螺钉M3×10	SCREW	1
37		413S13005	螺钉M6×10	SCREW	4
38		402S14001	螺钉	SCREW	1
39		413S14006	螺钉	SCREW	1
40		41327009	弹簧	SPRING	1
41		402S30032	悬挂螺钉	SUSPENSION SCREW	1

13. 压脚提升架、绕线器组件/LIFTING LEVER & BOBBIN WINDER COMPONENTS

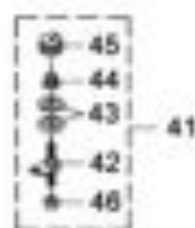
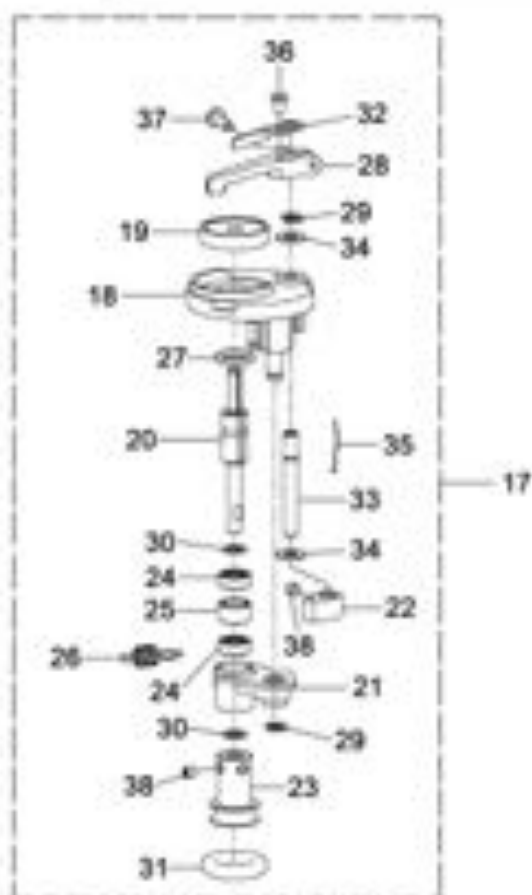
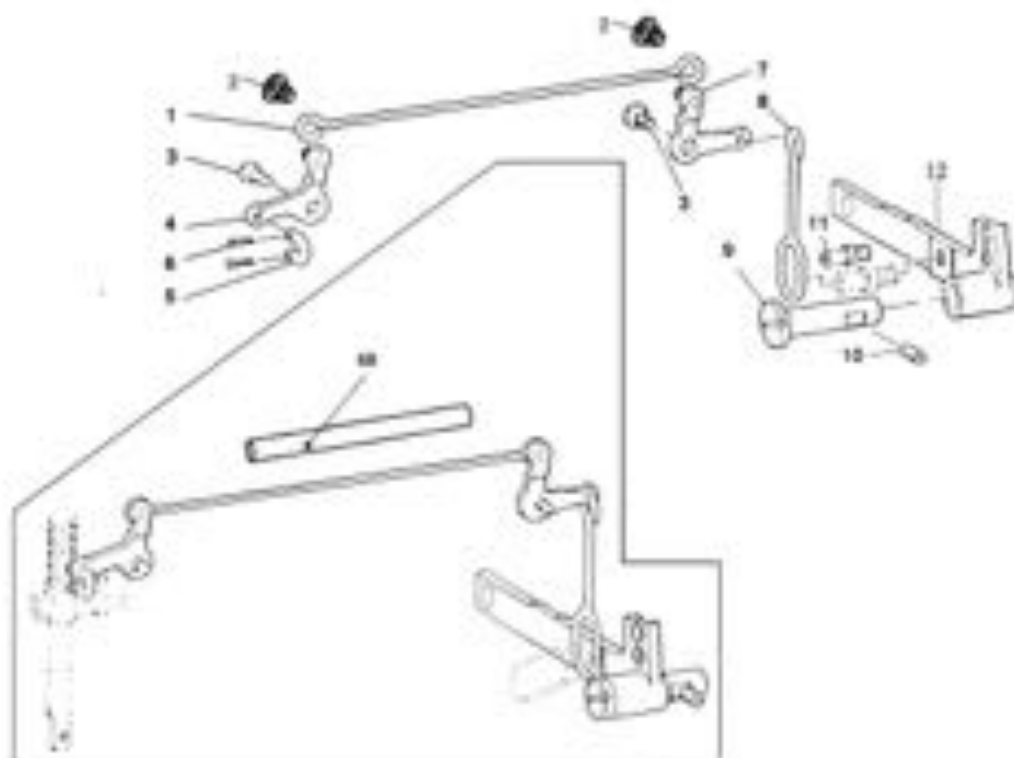

序号 NO.	注解 Note	件号 Part NO.	名称	Description	数量 Qty
1		40205012	压棒提升拉杆	PRESSER BAR LIFTING ROD LONG	1
2		402S20020	螺钉	SCREW	2
3		402S20021	轴位螺钉	HINGE SCREW	2
4		40205013	前杠杆板	LEVER FRONT	1
5		40204022	链环	LINK	1
6		402290010	开口销2×11	SPLIT PIN	2
7		40205014	后杠杆板	LEVER REAR	1
8		40205015	压棒提升拉杆	PRESSER BAR LIFTING ROD	1
9		40226036	离合杆铰链销	TRIPPING LEVER HINGE PIN	1
10		402S14001	螺钉	SCREW	1
11		402S30035	提升杆限位螺钉	LIFTING LEVER STOPPER	1
12		40201073	压棒提升杆	PRESSER BAR LIFTING LEVER	1
16		402S11037	绕线器安装螺钉	SCREW	3
17		4023101300	绕线器组件	BOBBIN WINDER ASM.	1
18		4021102200	绕线器安装座组件	BOBBIN WINDER BASE	1
20		40202041	绕线器轴	BTW SHAFT	1
21		4020403500	转动曲柄组件	BTW SHAFT BASE	1
22		40210010	转动凸轮	ROTARY CAM	1
23		40235025	转轮	BTW WHEEL	1
24		B04025	轴承686Z	BEARING	2
25		40208013	挡圈	BOBBIN BEARING SPACER	1
26		40227045	弹簧	SPRING	1
27		40222034	缓冲橡胶	RUBBER	1
28		40201062	梭心压杆	BTW LEVER	1
29		H05003	E型卡簧5	E-RING	2
30		40228029	垫片	WASHER	2
31		40222033	橡皮圈	BTW WHEEL RUBBER	1
32		40212100	绕线调节板	ADJUSTING PLATE	1
33		40202042	梭心压杆轴	BTW LEVER SHAFT	1
34		40228030	压杆轴垫片	WASHER	2
35		40227044	卡紧弹簧	SPRING	1
36		402S11039	螺钉	SCREW	1
37		402S11040	螺钉	SCREW	1
38		402S14007	紧定螺钉11/64×40	SCREW	3
39		11419001	割线刀	THREAD CUTTER	1
40		403S11020	螺钉	SCREW	2
41		4131300700	夹线器组件	BOBBIN THREAD TENSION ASM.	1
42		1143100300	过线销	BOBBIN THREAD TENSION ROD ASM.	1
43		11413003	夹线片	THREAD TENSION DISK	2
44		11427006	夹线簧	CONNECTING ROD SPRING	1
45		11411004	夹线螺母	THREAD TENSION NUT	1
46		114S16001	固定螺母	NUT 11/64-40	1
47		-----			
48		40203030	拉杆套管	TUBE	1

14. 夹线器关系 / THREAD TENSION COMPONENTS

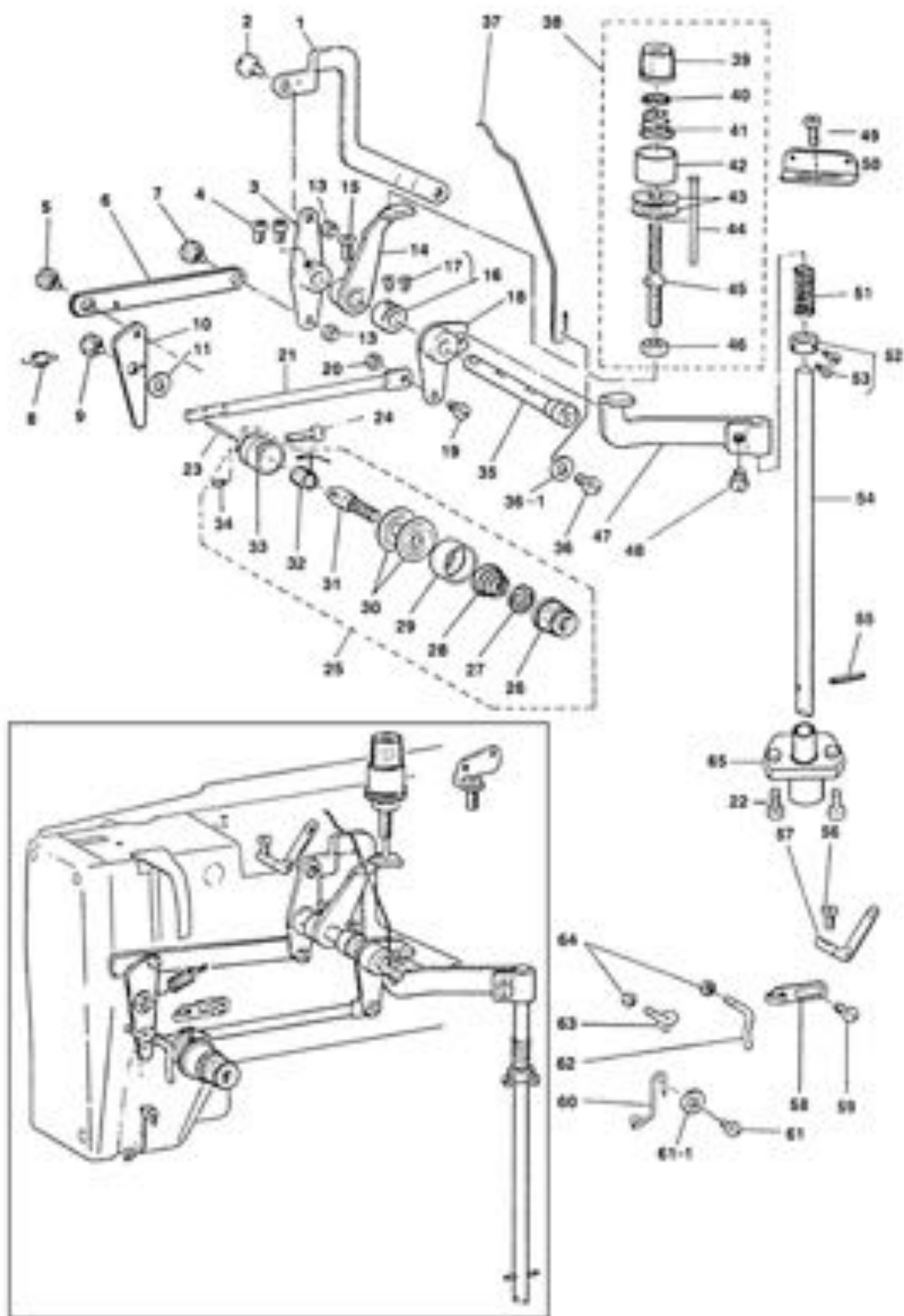

序号 NO.	注解 Note	件号 Part NO.	名称	Description	数量 Qty
1		40212104	松线连杆	TENSION RELEASE LINK	1
2		402S20025	轴位螺钉	HINGE SCREW	1
3		40205017	松线杆	TENSION RELEASE LEVER	1
4		409S14001	螺钉	SCREW	2
5		402S20026	轴位螺钉	HINGE SCREW	1
6		40212062	连杆板	BLOCKING LINK	1
7		402S20025	轴位螺钉	HINGE SCREW	1
8		40127020	弹簧1850-0809	BLOCKING ARM SPRING	1
9		402S20021	轴位螺钉	HINGE SCREW	1
10		40212063	杠杆板	BLOCKING ARM	1
11		40228018	垫圈	WASHER	1
12		-----			0
13		402S16001	螺母	NUT	2
14		4021212300	松线杆	TENSION RELEASE LEVER	1
15		402S11023	螺钉	SCREW	1
16		40208009	挡圈	THRUST COLLAR	1
17		201S14002	紧定螺钉	SCREW	2
18		40204023	松线杆曲柄	TENSION RELEASE LEVER CRANK	1
19		402S20028	轴位螺钉	HINGE SCREW	1
20		402S16017	螺母	NUT	1
21		40202028	松线杆	TENSION RELEASE ROD	1
22		S05049	螺钉	SCREW	2
23		40226037	松线销	TENSION RELEASE PIN	1
24		S09011	螺钉	SCREW	1
25		4021300800	夹线器2号组件	TENSION CONTROLLER NO.2 ASM	1
26		40211008	夹线调节手柄	TENSION NUT	1
27		40211009	夹线弹簧轴套	THREAD PULLING WIRE	1
28		40227046	夹线弹簧	TENSION SPRING	1
29		40212066	夹线盘压板	TENSION DISC PRESSER TUBE	1
30		40213005	夹线盘	TENSION DISC	2
31		402S30040	夹线柱	TENSION POST	2
32		40227031	挑线簧	THREAD TAKE-UP SPRING	1
33		40203032	夹线柱座	THREAD POST SOCKET	1
34		402S11024	螺钉	SCREW	1
35		40202055	松线杆轴	TENSION RELEASE LEVER SHAFT	1
36		-----			0
36-1		-----			0
37		-----			0
38		4021300700	1号夹线器组件	TENSION CONTROLLER NO.1 ASM.	1
39		40211010	夹线螺母	TENSION NUT	1
40		40211011	垫片	TENSION DISC STOPPER	1
41		40227047	夹线弹簧	TENSION SPRING	1
42		40212067	夹线压板	TENSION DISC PRESSER TUBE	1
43		40213008	夹线盘	TENSION DISC	2
44		40226038	松线销	TENSION RELEASE PIN	1
45		402S30041	2号夹线杆	TENSION POST	1
46		402S16018	螺母	NUT	1
47		40212068	松线臂	TENSION RELEASE ARM	1
48		402S30042	螺钉	SCREW	1
49		402S11013	螺钉	SCREW	1
50		40913010	导线板	THREAD GUIDE PLATE	1
51		40227023	弹簧	SPRING	1
52		40208010	挡圈	THRUST COLLAR	1
53		402S11022	螺钉	SCREW	2
54		40202030	松线柱	TENSION RELEASE ROD	1
55		P03030	销3×18	SPRING PIN	1
56		201S14002	螺钉	SCREW	1
57		40213009	二眼线钩	THREAD EYELET	1
58		40213010	右线钩	FRAME THREAD GUIDE	1
59		206S11002	螺钉	SCREW	1
60		40212070	针杆过线钩	NEEDLE BAR THREAD GUIDE	1
61		402S11003	螺钉	SCREW	1
61-1		W01013	垫圈	WASHER	1
62		40213011	第二紧线钩	TENSION THREAD GUIDE	1
63		40213012	挑线过线钩	TAKE-UP THREAD GUIDE	1
64		402S16017	螺母	NUT	2
65		40203033	定位架	POSITION BRACKET	1

15. 给油装置关系 / LUBRICATION MECHANISM COMPONENTS

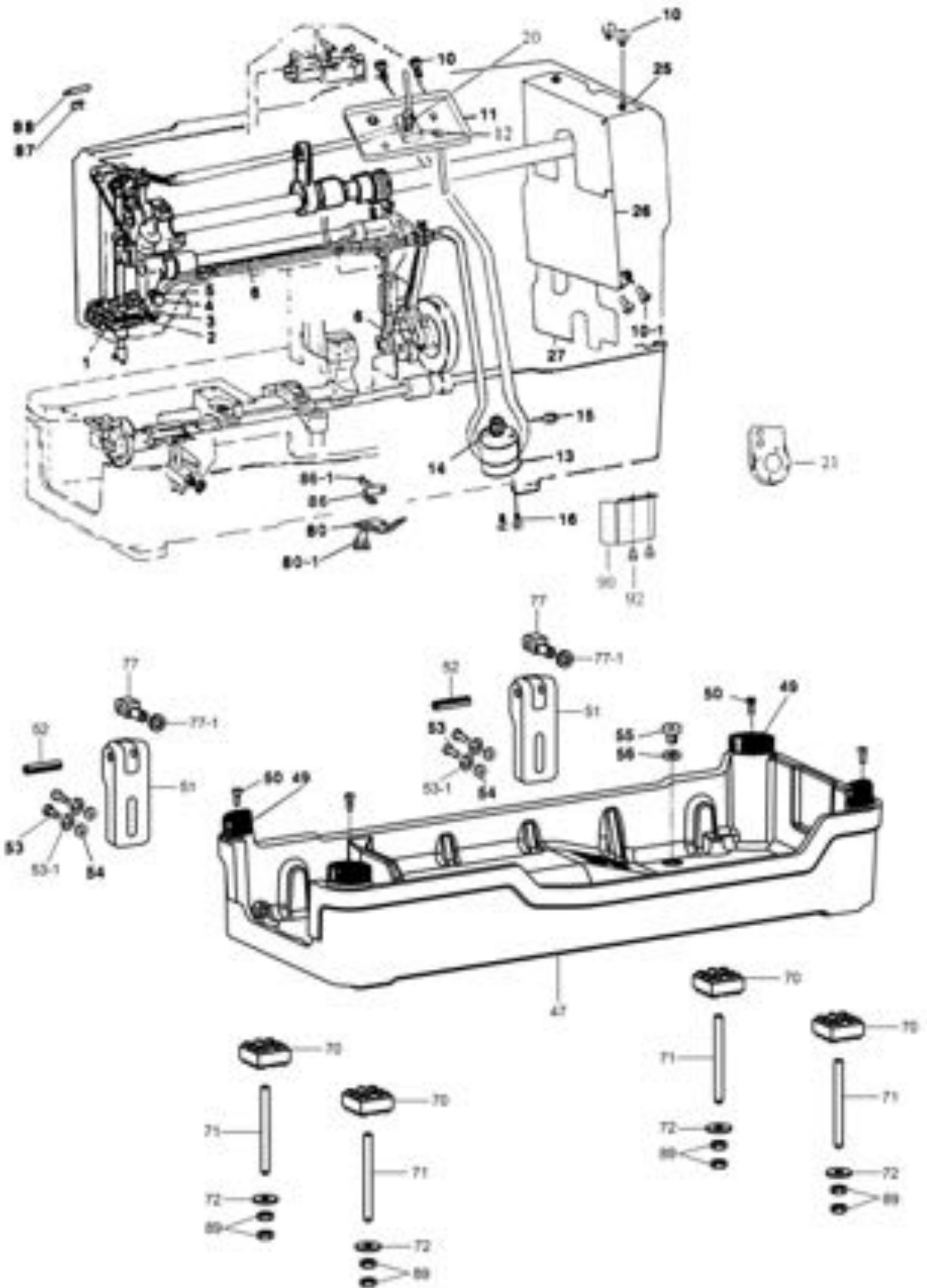

序号 NO.	注解 Note	件号 Part NO.	名称	Description	数量 Qty
1		-----			0
2		40223017	回油毡	OIL RETURN FELT	1
3		40221003	回油管	OIL RETURN TUBE	1
4		40212071	油管压板	CABLE HOLDER	1
5		402S11003	螺钉	SCREW	1
6		-----			0
7		-----			0
8		-----			0
9		-----			0
10		402S11003	螺钉	SCREW	2
10-1		206S11002	螺钉	SCREW	5
11		4021207300	盛油盘组件	OIL RECEIVER	1
12		400128	调节润滑螺钉座	OIL ADJUSTING SCREW BASE	1
13		4022000100	油泵座组件	OIL PUMP	1
14		40225012	油泵驱动蜗轮	OIL PUMP DRIVING WORM GEAR	1
15		201S14002		SCREW	2
16		S05003	螺钉M5×10	SCREW	2
17		-----	油毡导架	OIL FELT GUIDE	0
18		-----	螺钉	SCREW	0
19		-----	油量调节螺钉	HOOK OIL ADJUSTING SCREW	0
20		40227035	弹簧	SPRING	1
21		40212076	油泵板	OIL PUMP PLATE	1
22		-----			0
25		40212077	油罩	OIL SHIELD	1
26		40212078	油罩	OIL SHIELD	1
27		40212079	油罩	OIL SHIELD	1
47		40201066	油盘	OIL RESERVOIR	1
49		40222026	橡胶缓冲垫	RUBBER CUSHION	4
50		402S11003	螺钉	SCREW	4
51		40201020	铰链座300849	HINGE HOLDER	2
52		P03031	销P6×28	PIN	2
53		S05016	螺钉M6×25	SCREW	4
53-1		40128026	弹簧垫圈	SPRING WASHER	4
54		40228014	垫圈	WASHER	4
55		402S11026	螺钉	SCREW	1
56		40222027	垫片		1
68		-----	拨叉传动销		0
69		-----	橡胶套		0
70		40222028	油盘缓冲垫	MACHINE BASE FELT PAD	4
71		402S30048	油盘螺栓	MACHINE BASE SCREW STUD	4
72		40228019	垫圈	WASHER	4
77		40226039	连接销	CONNECTION STUD	2
77-1		40222031	橡胶垫圈	RUBBER WASHER	2
78		-----	油池		0
79		-----	O型环		0
80		40212081	油管固定板	PIPE RETAINER	1
80-1		206S11002	螺钉	SCREW	2
86		40212082	油管导架	PIPE GUIDE	1
86-1		206S11002	JK788-1175-3螺钉	SCREW	2
87		40212099	油线固定夹	OIL WICK LATCH	1
88		20626004	油线销	OIL WICK PIN	1
89		401S16002	螺母	NUT	4
90		40212106	挡油板	OIL BAFFLE	1
91		40223024	油毡	OIL FELT	1
92		413S13016	螺钉	SCREW	2