

# 目 录

序号	中文名	英文名	页码
1	缝纫机头组件结构和各种盖板	SEWING MACHINE COMPILATION FRAME & MISCELLANEOUS COVER COMPONENTS	1
2	主轴和挑线组件	MAIN SHAFT & THREAD TAKE-UP LEVER COMPONENTS	5
3	面线剪线组件	NEEDLE THREAD TRIMMER COMPONENTS	9
4	针杆分离机构	NEEDLE BRA REVERSAL COMPONENTS	11
5	夹线和过线组件	THREAD TENDION & WIPER COMPONENTS	13
6	底线剪线组件	LOWER THREAD COMPONENTS	15
7	中刀机构	CENTER KNIFE COMPONENTS	17
8	下轴组件	LOWER SHAFT COMPONENTS	19
9	左旋梭组件	HOOK DRIVING SHAFT LEFT COMPONENTS	21
10	右旋梭组件	HOOK DRIVING SHAFT RIGHT COMPONENTS	23
11	底线检测组件	BOBBIN THREAD DETECTING COMPONENTS	25
12	断线剪线组件	THREAD DETECTING COMPONENTS	27
13	润滑组件	LUBRICATION COMPONENTS	29
14	倒缝组件	BACK TUCK COMPONENTS	31
15	机架和台板组件(1)	MECHANISM COMPILATION FRAME & COVER COMPONENTS (1)	33
16	机架和台板组件(2)	FRAME & COVER COMPONENTS (2)	37
17	脚踏开关组件	PEDAL SWITCH COMPONENTS	39
18	角刀组件(1)(T5878-68B专用)	CORNER KNIFE COMPINENTS (FOR T5878-68B)	41
19	气动组件	AIR EQUIPMENT COMPONENTS	43
20	盖板组件	CLAMP FOOT COMPONENTS	45
21	角刀组件	CORNER KNIFE COMPONENTS	47
22	测布组件	BINDER COMPONENTS	49
23	角刀组件(2)(T5878-68B专用)	CORNER KNIFE UNIT (FOR T5878-68B)	51
24	袋盖传感器部件	FLAP PHOTOTUBE COMPONENTS	55
25	线架组件	THREAD SHAFT COMPONENTS	57
26	附件组件	ACCESSORIE PART COMPONENTS	59
27	电控箱组件	TRANSMISSION BOX COMPONENTS	61
28	操作面板组件	OPERATION PANEL COMPONENTS	63
29	主轴和挑线组件(T5878-68B专用)	MAIN SHAFT & THREAD TAKE-UP LEVER COMPONENTS (FOR T5878-68B)	65
30	压脚组件(1)	UNIT MECHANISM COMPILATION CLAMP FOOT UNIT (1)	67
31	压脚组件(2)	CLAMP FOOT UNIT (2)	69
32	压脚组件(3)	CLAMP FOOT UNIT (3)	71
33	压脚驱动单元	CLAMP FOOT FEED UNIT	73
34	角刀组件(1)	CORNER KNIFE UNIT (1)	75
35	角刀组件(2)	CORNER KNIFE UNIT (2)	79
36	角刀组件(3)	CORNER KNIFE UNIT (3)	83
37	中压板组件	BINDER UNIT	85
38	定位灯组件	MARKING LIGHT UNIT	89
39	裤省定位杆组件	CLOTH LENGTHEN DEVICE	91
40	三明治送布组件	PAVING PLATE DEVICE	93
41	卷线组件	BOBBIN WINDER MECHANISM	95
42	衬布压板组件	POCKET BAG CLAMP COMPONENTS	97
43	堆叠器组件(1)	CLAMP BAR STACKER DEVICE (1)	99
44	堆叠器组件(2)	CLAMP BAR STACKER DEVICE (2)	103
45	滚布轮装置	ROLLER STACKER DEVICE	105
46	针位元件(1)	GAUGE COMPONENTS (1)	107
47	针位元件(2)	GAUGE COMPONENTS (2)	108
48	针位元件(3)	GAUGE COMPONENTS (3)	109
49	气路回转图	PNEUMATIC CIRCUIT DIAGRAM	110
50	接线图	WIRING DIAGRAM	113

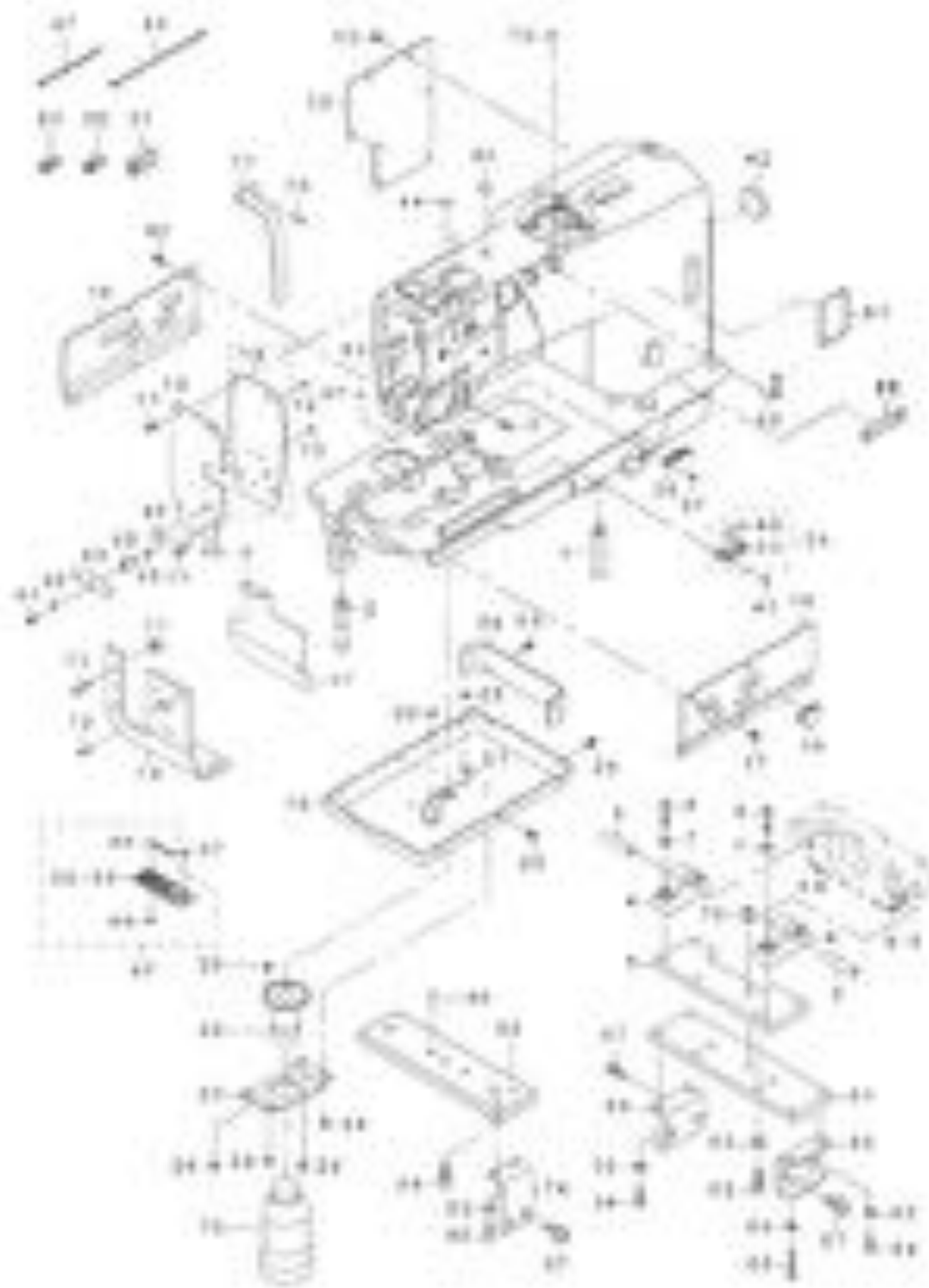

1、缝纫机头组件结构及各盖板/SEWING MACHINE COMPILATION FRAME&MISCELLANEOUS COVER COMPO

序号 Ref.No.	公司件号 Part No.	名 称	Description	数量 Amt.
1	129S30001	脚柱L	BED LEG L	1
2	129S30002	脚柱S	BED LEG S	1
3	S04028	螺钉M5x8	SCREW M5X8	2
4	400695	机头基座A	HEAD BASE A	2
5	400920	机头板块B	HEAD BASE PLATE B	1
6	S05084	螺钉M6x25	HEXAGONAL-HOLE BOLT	4
7	42128023	垫圈 M6	WASHER M6	4
8	42102053	机头固定轴	HEAD FIXED SHAFT	2
9	S09009	螺钉M5X10	SCREW M5x10	2
10	301982	机头盖板	HEAD COVER	1
11	421S10010	螺钉M5X8	SCREW M5x8	4
12	P03005	定位销	SPRING PIN	1
13	P05005	定位销	SPRING PIN	1
14	301981	机头盖板	HEAD COVER	1
15	42112198	油盘前固定板	OIL COVER A FRONT	1
16	42112247	油盘后固定板	OIL COVER A BACK	1
17	421S11008	螺钉M4X10	SCREW M4X10	2
18	42122030	橡胶塞	FACE COVER CAP	4
19	42112199	油盒	OIL COVER B	1
20	421S11008	螺钉M4X10	SCREW M4X10	6
21	42123001	油线	OIL WICK	1
22	N01001	螺母M4	NUT M4	2
23	42112200	油壶支架	OIL MANAGEMENT BRACKET	1
24	421S10001	螺钉M4X8	SCREW M4X8	4
25	40311010	油壶接头	OIL MANAGEMENT	1
26	421S11012	螺钉M3X10	SCREW M3X10	4
27	42137002	绑扎带	CABLE BAND	15
28	42137002	绑扎带	CABLE BAND	15
29	61910020	线夹	CABLE CLAMP	3
30	61910021	线夹	CABLE CLAMP	3
31	61910022	线夹	CABLE CLAMP	4
32	12912002	侧板	REAR COVER	1
33	S04029	螺钉M5X12	SCREW M5X12	4
34	S05028	螺钉M6x14	SCREW M6X14	1
35	42128023	垫圈 M6	WASHER M6	1
36	42113013	导线中支架	THREAD GUIDE M	1
37	421S17010	螺钉M4X7	SCREW M4X7	1
38	4211301100	导线下支架组件	THREAD GUIDE F ASM	1
39	42113014	导线下支架	THREAD GUIDE F	1
40	42123002	毛毡	FELT	1
41	421S10041	螺钉M5X6	SCREW M5X6	1
42	42122038	橡皮塞	CAP	1
43	12922001	橡皮塞12.5	RUBBER CAP 12.5	1
44	12922001	橡皮塞12.5	RUBBER CAP 12.5	2
45	421S11008	螺钉M4X10	SCREW M4X10	2
46	12922001	橡皮塞12.5	RUBBER CAP 12.5	1
47	4211500100	针板10 组件	NEEDLE PLATE 10 ASM.	1
48	4211901200	中刀定刀组件	CONTER KNIFE RIGHT	1
49	421S10034	螺钉 1/8-44X2.5	SCREW 1/8-44X2.5	2

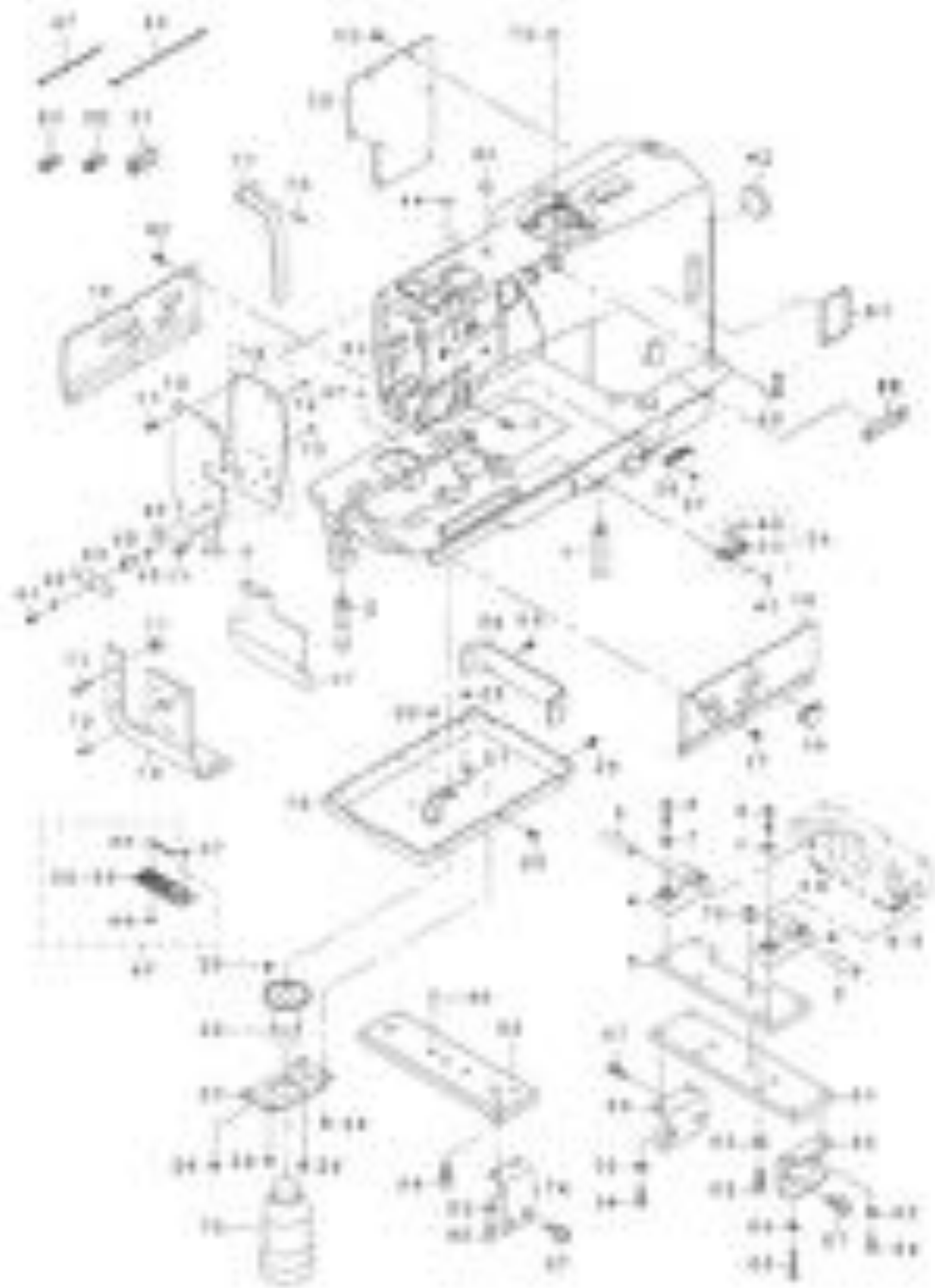

50	42115001	针板10	NEEDLE PLATE 10	1
51	42115002	针板8	NEEDLE PLATE 8	1
52	42115003	针板12	NEEDLE PLATE 12	1
53	42115004	针板14	NEEDLE PLATE 14	1
54	42115005	针板16	NEEDLE PLATE 16	1
55	42115006	针板18	NEEDLE PLATE 18	1
56	42115007	针板20	NEEDLE PLATE 20	1
57	42112201	油盘盖板B	BED OIL COVER B	1
58	42112202	油盘盖板C	BED OIL COVER C	1
59	421S11008	螺钉M4X10	SCREW M4X10	2
60	421S11008	螺钉M4X10	SCREW M4X10	2
61	42101113	机头底板A	HEAD BASE PLATE A	1
62	421S13018	螺钉M8X20	SCREW M8X20	2
63	W01010	垫圈M8	WASHER M8	2
64	S05028	螺钉M6x14	SCREW M6X14	3
65	42128023	垫圈 M6	WASHER M6	5
66	42112203	固定板	FIXING PLATE	2
67	421S13018	螺钉M8x20	SCREW M8X20	6
68	S05083	螺钉M5X30	SCREW M5X30	4
69	N01004	螺母M5	NUT M5	4
70	42112204	机头前固定板	HEAD FRONT BASE	1
71	42108018	管套	FRONT BASE SPACER	2
72	421S10019	螺钉M5x14	SCREW M5X13.5	2
73	421S13077	螺钉M5x30	SCREW M5X30	2
74	42112205	机头固定板	HEAD ROCK PLATE	1
75	40311011	接油壶	OIL CAN	1
76	42126019	定位销	FIXED PIN	1
77	42112234	挑线杆防护罩	THREAD TAKE UP LEVER COVER B	1
78	421S13035	螺钉M4X8	SCREW M4X8	2
79	S10019	螺钉M6X6	SCREW M6X6	2
80	413S13023	螺钉M6X12	BOLT	2
81	42137030	警告标识	WARNING LABEL	1
82	42137031	警告标识	WARNING LABEL	1
83	42137032	警告标识	WARNING LABEL	1
85	400921	支撑固定板	SUPPORTING AND FIXING PLATE	1
86	42126023	固定销	PIN	1
87	407S17015	螺钉	SCREW	2
88	42137033	商标牌	MIDEL NAME PLATE	1
89	42102054	卡轴	ROCK SHAFT	1
90	421S30026	卡轴垫套	FEED BASE SPACER	2
91	421S11008	螺钉M4x10	SCREW M4X10	2
92	12913010	三眼线勾	THREAD RETAINER	2
94	421S13018	螺钉M8X20	SCREW M8X20	2
95	42128053	垫圈	WASHER	2
96	42128054	垫圈	WASHER	2
97	P01020	销3x10	PIN	2
98	421S13027	螺钉M5x12	SCREW M5X12	3

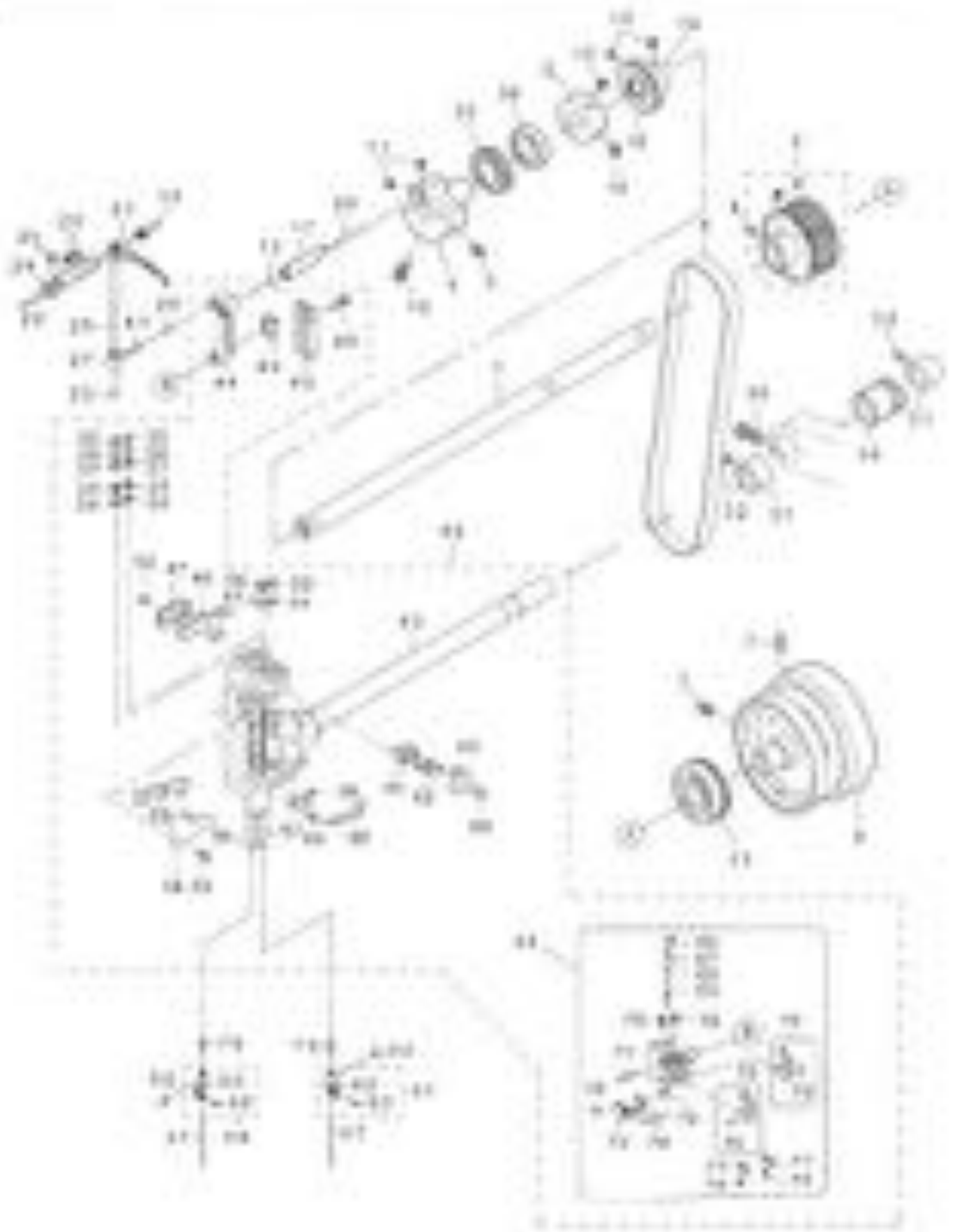

## 2、主轴和挑线组件/MAIN SHAFT&THREAD TAKE-UP LEVER COMPONENTS

序号 Ref.No.	公司件号 Part No.	名 称	Description	数量 Amt.
1	12902014	上轴ST	UPPER SHAFT ST	1
2	12908001	卷线驱动轮	BOBBIN WINDER DRIVING WHEEL	1
3	12935002	同步轮UST组件	TIMING PULLEY ASSY UST	1
4	S10018	螺钉M6X6	SCREW M6X6	2
5	12935003	同步带	TIMING BELT	1
6	301079	手轮	HAND WHEEL	1
7	S10024	螺钉M6X10	SCREW M6X10	2
8	12904006	挑线杆曲柄	THREAD TAKEUP CRANK	1
9	S09017	螺钉M6X10	SCREW M6X10	1
10	129S30005	螺钉M8X6	SCREW M8X6	1
11	S10017	螺钉M6X5	SCREW M6X5	2
12	S10018	螺钉M6X6	SCREW M6X6	2
13	B10009	球轴承6204ZZNR	BALL BEARING 6204ZZNR	1
14	12908002	轴承套座	BALL BEARING BUSH	1
15	B04021	R球轴承60/22ZZ	BALL BEARING RADIAL 60/22ZZ	1
16	S10018	螺钉M6X6	SCREW M6X6	2
17	12926201	针杆曲柄销	CRANKSHAFT NBAR	1
18	11626003	油线盖	PUSHER	1
19	12938002	挑线杆支撑接头	THREAD TAKEUP LEVER SUPPORT JOINT	1
20	12923019	油线	OIL WICK	0.02
21	12938202	挑线杆	TAKE UP LEVER E	1
22	12923019	油线	OIL WICK	0.04
23	12926016	油线盖	RUBBER PLUG	1
24	12938003	挑线架销	THREAD TAKE-UP LEVER PIN	1
25	12923031	油毡	OIL WICK	0.15
26	S10024	螺钉M6X10	SCREW M6X10	2
27	11626004	挑线杆连接柱	TAKE UP LEVER THRUST PIN	1
28	12922015	橡皮塞	PLUG	1
29	12923012	油毡	OIL WICK	2
30	12903002	摆动轴轴套R	BUSH R	1
31	12908003	紧圈	SET SCREW COLLAR	2
32	S10017	螺钉M6X5	SCREW M6X5	4
33	B10002	球轴承6004ZZNR	BALL BEARING 6004ZZNR	1
34	B04022	球轴承6004ZZ	BALL BEARING 6004ZZ	1
35	S10025	螺钉 M8X8	SCREW M8X8	2
36	12928021	衬垫 5.3	SPACER 5.3	2
37	S10025	螺钉 M8X8	SCREW M8X8	2
38	S04016	螺钉 M3.5X6	SCREW M3.5X6	2
39	W01001	垫圈	WASHER	2
40	S05048	螺钉M4x10	SCREW M4X10	2
41	12923021	油线	OIL WICK	0.02
42	4210119400	针杆摆动轴组件	NEEDLE BAR ROCKING COMPONENTS	1
43	4210119300	针杆台组件	NEEDLE BAR ROCKING BASE ASM	1
44	12905016	针杆曲柄连杆	NEEDLE BAR CRANK ROD	1
45	12909001	角滑块槽	SLIDE BLOCK SLIDER	1
46	12909008	角滑块	ROCKING ROD SQUARE BLOCK	1
47	12912101	油毡上支架U	FELT SUPPORT U	1
48	12923029	油毡	FELT	1
49	12923028	油毡	FELT	2





50	129S20005	螺钉SM3.5	SCREW SM3.5	2
51	12912073	针杆定位	ROTATE STOPPER NBAR	2
52	S04041	螺钉 M3.5X5	SCREW M3.5X5	1
53	12909007	滑块组件	SLIDE BLOCK ASSY	1
54	12912070	角滑块导向板	SLIDE BLOCK GUIDE PLATE	1
55	129S30021	螺钉M3.5X8	SCREW M3.5X8	1
56	4210206600	针杆组件L	NEEDLE BAR ASSY L	1
57	4210206700	针杆组件R	NEEDLE BAR ASSY R	1
58	12912074	油毡下支架D	FELT SUPPORT D	1
59	S04016	螺钉 M3.5X6	SCREW M3.5X6	2
60	12923027	油毡	FELT	1
61	12912071	针杆定位	STOPPER NBAR	2
62	11727004	针杆止动器弹簧	SPRING NBAR STOPPER	2
63	12912072	弹簧盖	SPRING COVER	1
64	S04016	螺钉 M3.5X6	SCREW M3.5X6	1
65	12902017	针杆抱箍组件	NEEDLE BAR CLAMP ASSY	1
66	129S30030	螺钉 M2.6X5	SCREW M2.6X5	1
67	1901007	离合销盖	PIN COVER	1
68	11727003	离合销弹簧	SPRING RELEASE PIN	1
69	11726006	销	PIN	1
70	12927019	离合器摆杆弹簧	SPRING CLUTCH LEVER	2
71	11726004	销 2X15.8	PIN 2X15.8	1
72	129S3029	螺钉 M2.6X3	SCREW M2.6X3	2
73	12912067	弹簧支架	SPRING HOLDING	1
74	11726005	销 2X17.8	PIN 2X17.8	1
75	12912068	离合器摆杆组件	CLUTCH LEVER ASSY	2
76	11726003	销 1.5X5.8	PIN 1.5X5.8	2
77	12912065	止动块L	CLUTCH STOPPER L	2
78	11727002	推动板止动簧	SPRING	2
79	421S10035	螺钉M2.5x3.5	SCREW M2.5x5	2
80	S10026	螺钉M3X3	SCREW M3X3	2
81	4213400200	针夹头10组件(右)	NEEDLE CLAMP D 10MM RIGHT	1
82	42134002	针夹头10(右)	NEEDLE CLAMP D 10MM RIGHT	1
83	421S10035	螺钉M2.5X3.5	SCREW M2.5x3.5	1
84	4213400100	针夹头10组件(左)	NEEDLE CLAMP D 10MM LEFT	1
85	42134001	针夹头10(左)	NEEDLE CLAMP D 10MM LEFT	1
86	421S10035	螺钉M2.5X3.5	SCREW M2.5x3.5	1
87	42117001	机针DP×17 #16	NEEDLE DP×17 #16	2
88	S04031	螺钉M6X16	SCREW M6X16	1

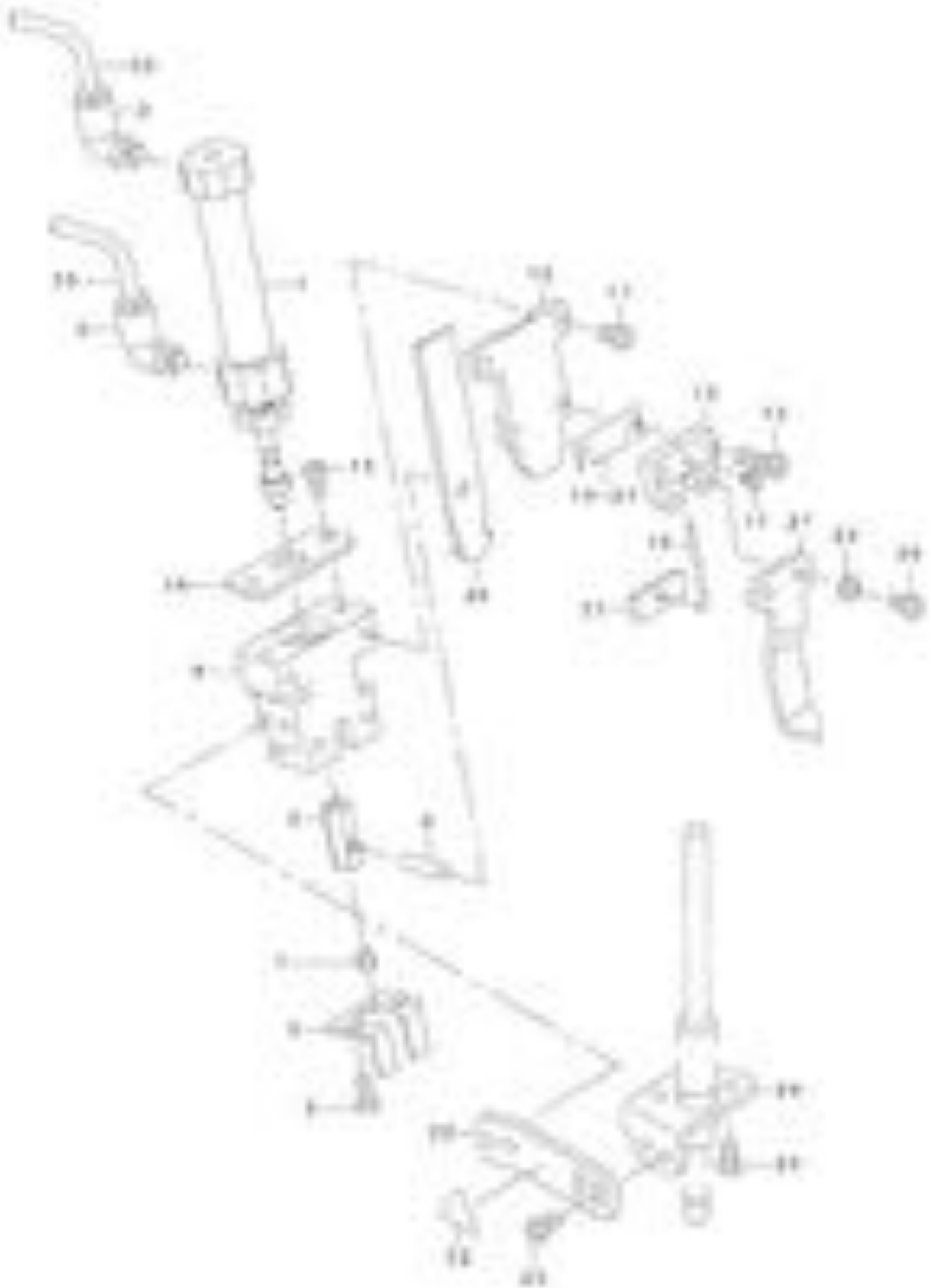

### 3、面线剪刀组件/NEEDLE THREAD TRIMMER COMPONENTS

序号 Ref.No.	公司件号 Part No.	名 称	Description	数量 Amt.
1	42130001	气缸	ARI CYLINDER	1
2	42136001	弯管接头	ELBOW UNION	1
3	42136001	弯管接头	ELBOW UNION	1
4	401758	面线剪刀支架	UPPER KNIFE BASE	1
5	42126001	面线剪刀连接栓	UPPER KNIFE JOINT	1
6	42102001	驱动轴	HINGE SHAFT	1
7	S10006	螺钉M5x6	SCREW M5X6	1
8	42119001	面线定刀	NEEDLE THREAD COUNTER KNIFE	1
9	421S10001	螺钉M4x8	SCREW M4X8	2
10	400733	面线动刀导向板	UPPER KNIFE GUIDE	1
11	421S10001	螺钉M4x8	SCREW M4X8	2
12	400735	夹线夹板	UPPER KNIFE CLAMP BASE	1
13	421S10002	螺钉M4x16	SCREW M4X16	2
14	42112002	气缸固定板	UPPER KNIFE PLATE	1
15	421S10001	螺钉M4x8	SCREW M4X8	2
16	42113001	压线杆	CLAMP SPRING	1
17	421S10003	螺钉M3x4	SCREW	1
18	42113002	夹线片0.2	SPACER 0.2	1
19	42113003	夹线片0.4	SPACER 0.4	1
20	42113004	夹线片0.6	SPACER 0.6	1
21	42113005	夹线片0.8	SPACER 0.8	1
22	42112003	面线机构固定板	UPPER THREAD TRIMMER PLATE	1
23	421S13019	螺钉M4x6	SCREW M4X6	4
24	42112004	面线机构固定架	UPPER THREAD TRIMMER BASE	1
25	101S13012	螺钉M4x10	SCREW M4X10	2
26	42119003	面线动刀10-12	UPPER KNIFE 10-12	1
27	42112005	分布器	CLOTH SPREADER	1
28	421S10001	螺钉M4x8	SCREW M4X8	2
29	42128014	垫圈	WASHER	2
30	61911001	气管	URETHANE HOSE BLACK	2
31	42112006	面线夹	CLAMP PLATE	1
32	42137001	警告标签	ATTENTION SEAL	1

※ 序号18、19、20、21为选用零件。

18、19、20、21 SELECTIVE PARTS.

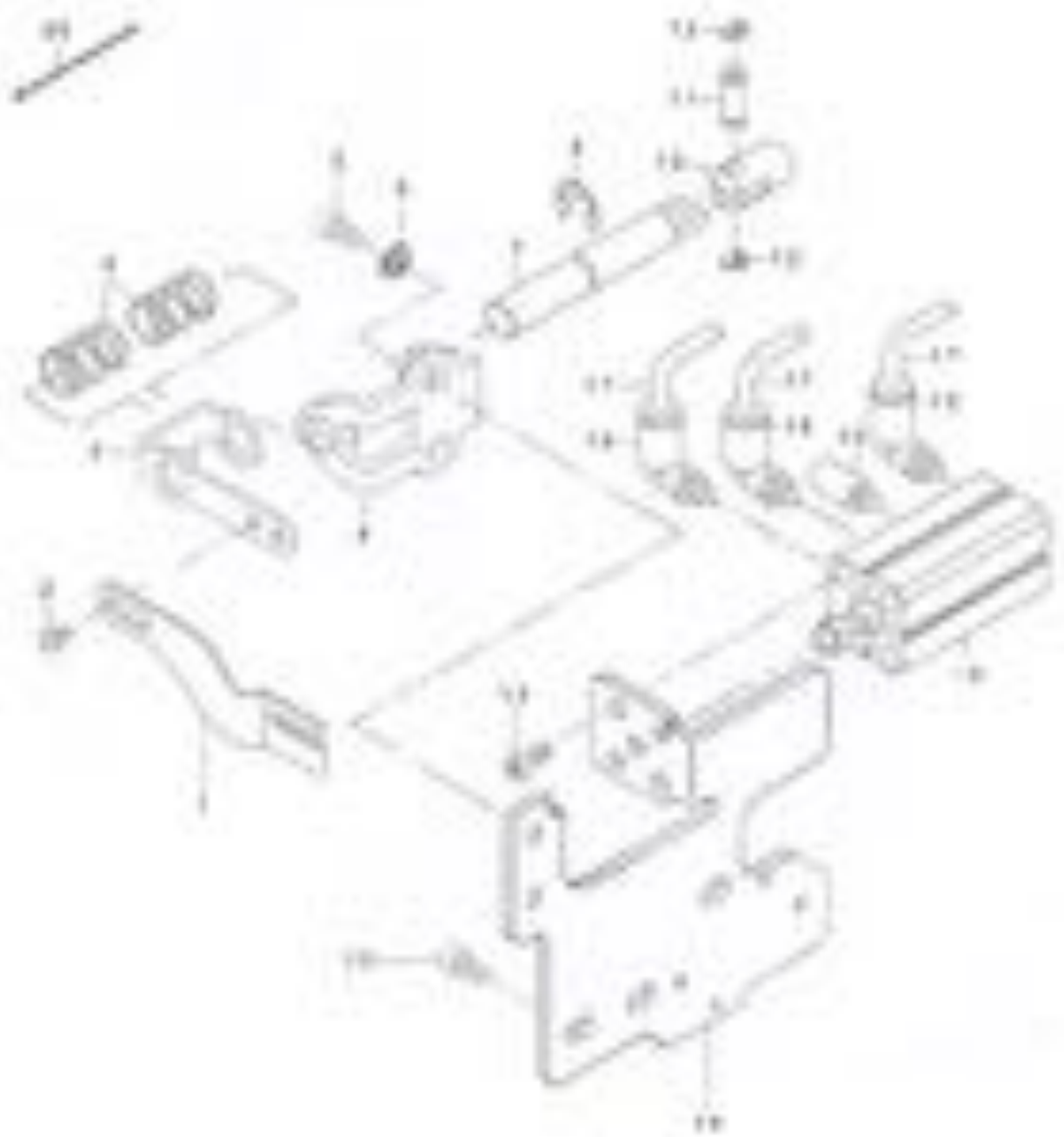

#### 4、针杆分离机构/NEEDLE BAR REVERSAL COMPONENTS

序号 Ref.No.	公司件号 Part No.	名 称	Description	数量 Amt.
1	42112007	分离驱动片	LEAF SPRING	1
2	S04080	螺钉M4x4	SCREW M4X4	2
3	42112008	分离驱动支架	LEAF SPRING PLATE	1
4	42101003	支撑支架	SHAFT GUIDE BASE	1
5	S05067	螺钉M5x10	BOLT	2
6	42128015	垫圈	WASHER	2
7	42102002	驱动轴	CYLINDER SHAFT	1
8	H05008	卡簧8	E-RING 8	1
9	42127001	平衡弹簧	BALANCE SPRING	2
10	42136003	气缸接头	CYLINDER KNUCKLE	1
11	42126002	气缸销	CYLINDER PIN	1
12	H05012	挡圈E4	RETAINING RING E4	2
13	S05087	螺钉M5x12	SCREW M5X12	4
14	42112009	汽缸支架	REVERSAL BASE	1
15	S05067	螺钉M5x10	BOLT	3
16	42128001	消音器	SILENCER	1
17	61911001	气管	URETHANE HOSE BLACK	0.4
18	42136004	弯管接头	ELBOW UNION	3
19	42130004	气缸	AIR CYLINDER	1
20	42137002	绑扎带	CABLE BAND	3

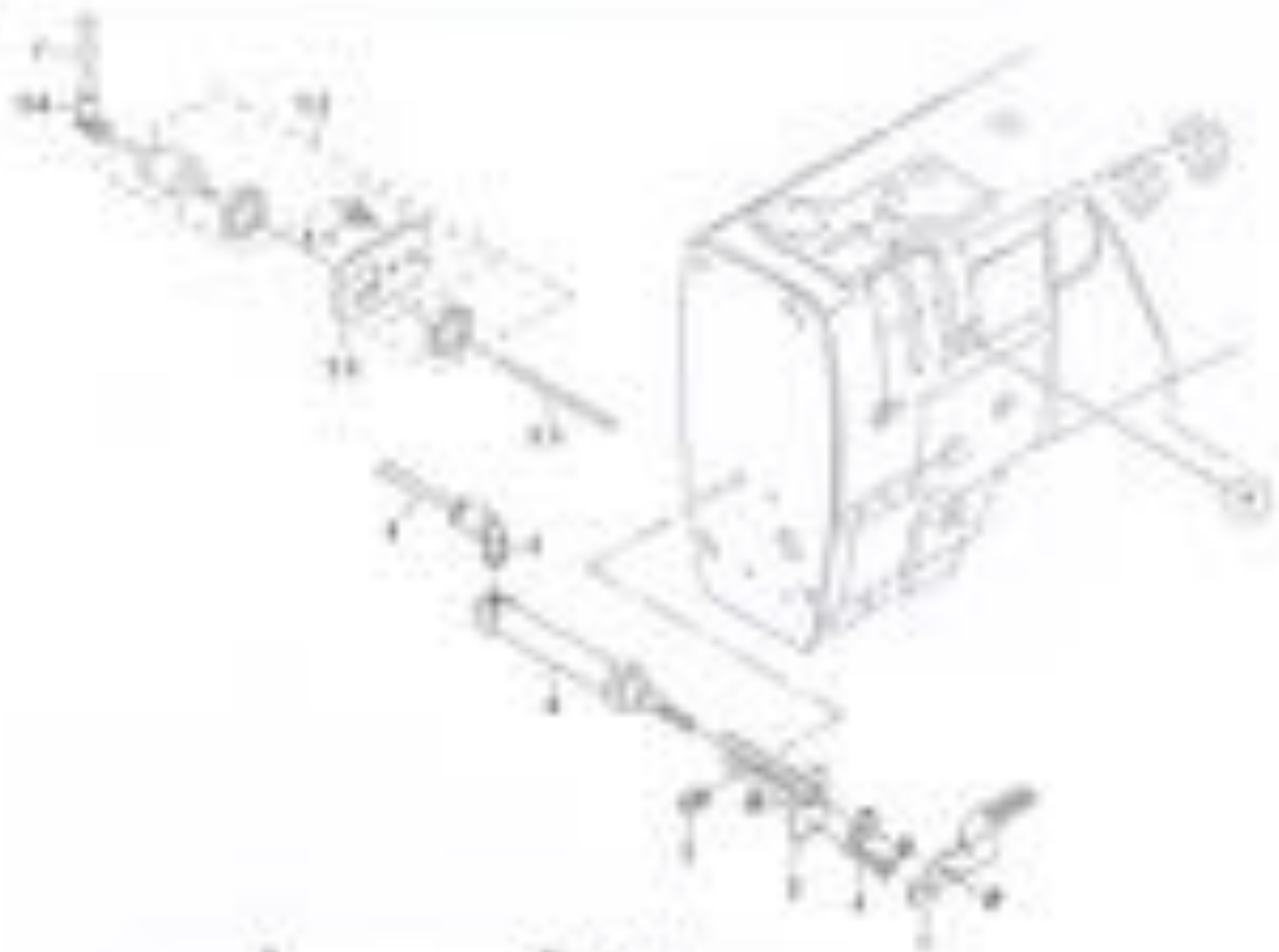

### 5、夹线和过线组件/THREAD TENSION&WIPER COMPONENTS

序号 Ref.No.	公司件号 Part No.	名称	Description	数量 Amt.
1	42112010	送线器	WIPER	1
2	42112011	送线支架	WIPER CYLINDER BASE	1
3	421S13003	螺钉M4x10	BOLT	2
4	42130005	气缸	CYLINDER	1
5	42136001	弯管接头	ELBOW UNION	1
6	421S3000100	限位螺钉	STOPPER BOLT	1
7	61911001	气管	URETHANE HOSE BLACK	3
8	61911001	气管	URETHANE HOSE BLACK	3
9	1291300300	面线调节组件3	UPPER THREAD TENSION ASSY 3	1
10	S04028	螺钉M5x8	SCREW M5X8	2
11	12912043	调整台组件	TENSION PLATE ASSY	1
12	12927008	弹簧L	TENSION SPRING L	2
13	12926010	调整短轴	TENSION STUD	1
14	12927010	弹簧L	TENSION SPRING L	1
15	1291300500	导向组件	GUIDE ASSY	2
16	12928012	垫片	SPACER	1
17	12927011	弹簧R	TENSION SPRING R	1
18	12903014	轴套	COLLAR	1
19	12908006	定位圈	STOPPER SUPPORT	1
20	N01013	螺母M3	NUT M3	1
21	129S15006	螺钉M3.5	SCREW M3.5	1
22	129S11008	固定螺栓	SPRING GUIDE SET SCREW	1
23	12913006	调节旋钮	ADJUSTING THUMB	1
24	129S15006	螺钉M3.5	SCREW M3.5	1
25	12903015	轴套	COLLAR	1
26	129S30018	调线螺母	TENSION NUT	1
27	12912044	弹簧限位板	STOPPER	1
28	129S17004	螺钉M3.5X6	SCREW M3.5X6	1
29	12912084	定位螺钉M3.5	NUT WHIRLSTOP M3.5	1
30	12912045	限位板	STOPPER	1
31	129S30026	螺钉M3.5X5	SCREW M3.5X5	1
32	12913007	夹线盘	DISC TENSION	4
33	12913008	夹线压盘	TENSION DISC PRESSER	2
34	12911008	调节弹簧垫圈	WASHER	2
35	129S30019	调节螺母	TENSION NUT	2
36	12928013	小夹线垫片	THREAD GUIDE DISC	4
37	12927012	小夹线弹簧A	PRETENSION SPRING A	2
38	129S30012	夹线螺母	TENSION NUT	2
39	12913009	松线板	TENSION RELEASE PLATE	1
40	S09049	螺钉M5X5	SCREW M5X5	1
41	12927013	松线弹簧	TENSION SPRING	1
42	129S30020	轴位螺钉M3.5	SHOULDER SCREW M3.5	2
43	12926011	松线销L	TENSION RELEASE PIN L	1
44	12926012	松线销R	TENSION RELEASE PIN R	1
45	12912046	线导向U	THREAD GUIDE U	1
46	129S17004	螺钉M3.5X6	SCREW M3.5X6	2
47	12912047	线调整	THREAD QUANTITY ADJUST	1
48	129S30027	螺钉M3X6	SCREW M3X6	1
49	12911022	盖	CAP	1
50	42112012	松线气缸支架	THREAD TENSION CYLINDER BRACKET	1
51	421S13003	螺钉M4x10	BOLT	2
52	42130006	气缸	AIR CYLINDER	1
53	12902011	松线轴	BAR TENSION RELEASE	1
54	42136001	弯管接头	ELBOW UNION	1

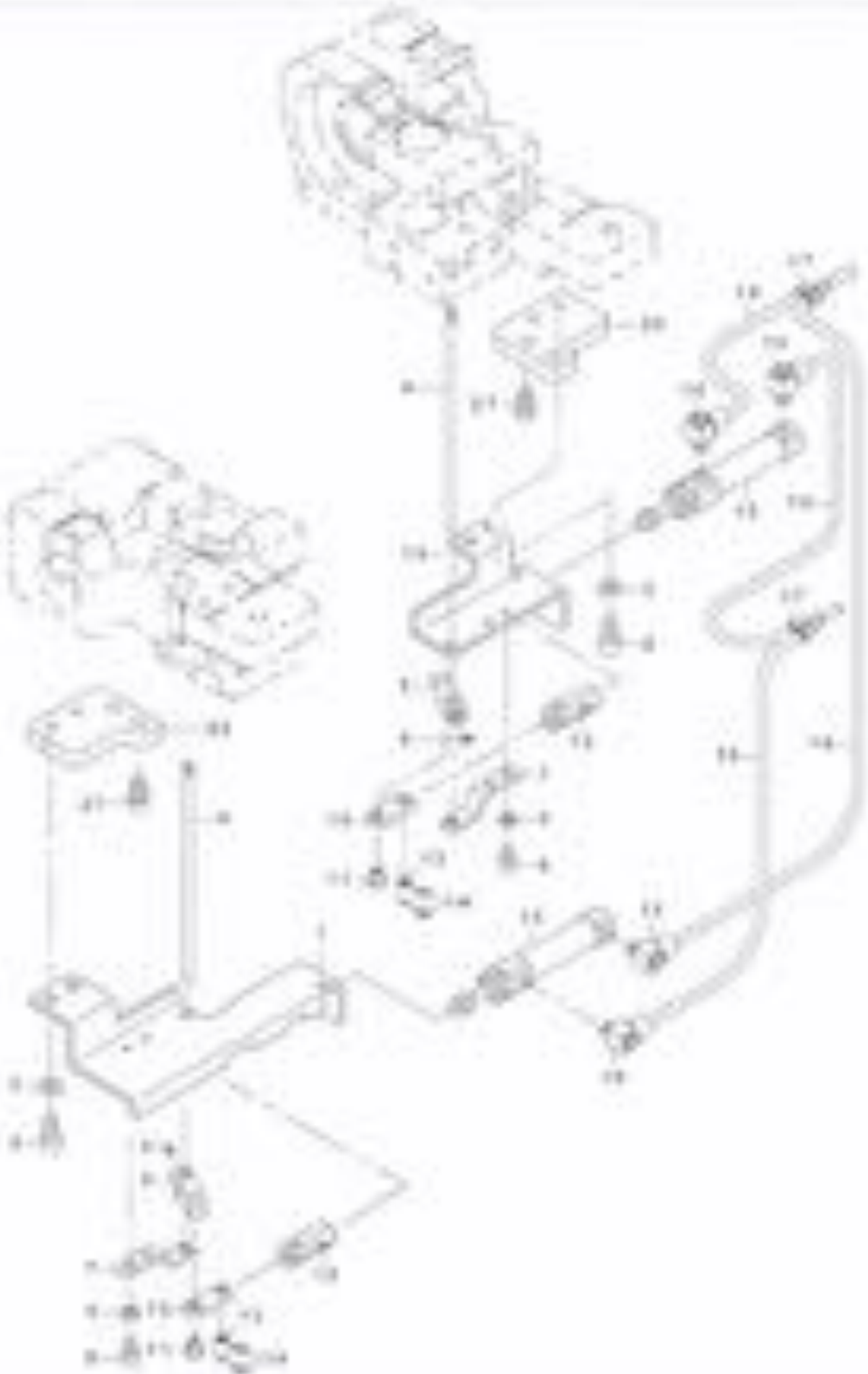



**6、底线剪线组件/LOWER THREAD COMPONENTS**

序号 Ref.No.	公司件号 Part No.	名称	Description	数量 Amt.
1	42112013	左底线剪线支架	LOWER KNIFE BASE L	1
2	421S13059	螺钉M5x20	BOLT	4
3				
4	42119007	底线剪刀	LOWER KNIFE	2
5	401755	旋转驱动块	KNIFE LINK ARM	2
6	421S14003	螺钉	SCREW	2
7	42112014	角刀支撑件	KNIFE PRESSER BASE	2
8	413S13003	螺钉M4x6	SCREW M4X6	4
9	42128014	垫圈	WASHER	4
10	400748	驱动连接块	LOWER KNIFE LINK	2
11	421S20001	轴位螺钉	HINGE SCREW	2
12	42136006	Y型气缸接头	CYLINDER JOINT	2
13	42102004	连接轴	LINK PIN	2
14	H03018	轴用弹性挡圈4	SNAP RING	4
15	42130007	气缸	AIR CYLINDER	2
16	42136007	弯管接头	HOSE ELBOW	4
17	40736036	Y型气管接头	QUICK COUPLING	2
18	61911001	气管	URETHANE HOSE BLACK	6
19	42112016	右底线剪线支架	LOWER KNIFE BASE R	1
20	400922	安装固定块	FIXED BLOCK	2
21	421S13028	螺钉M5x14	SCREW M5x14	4

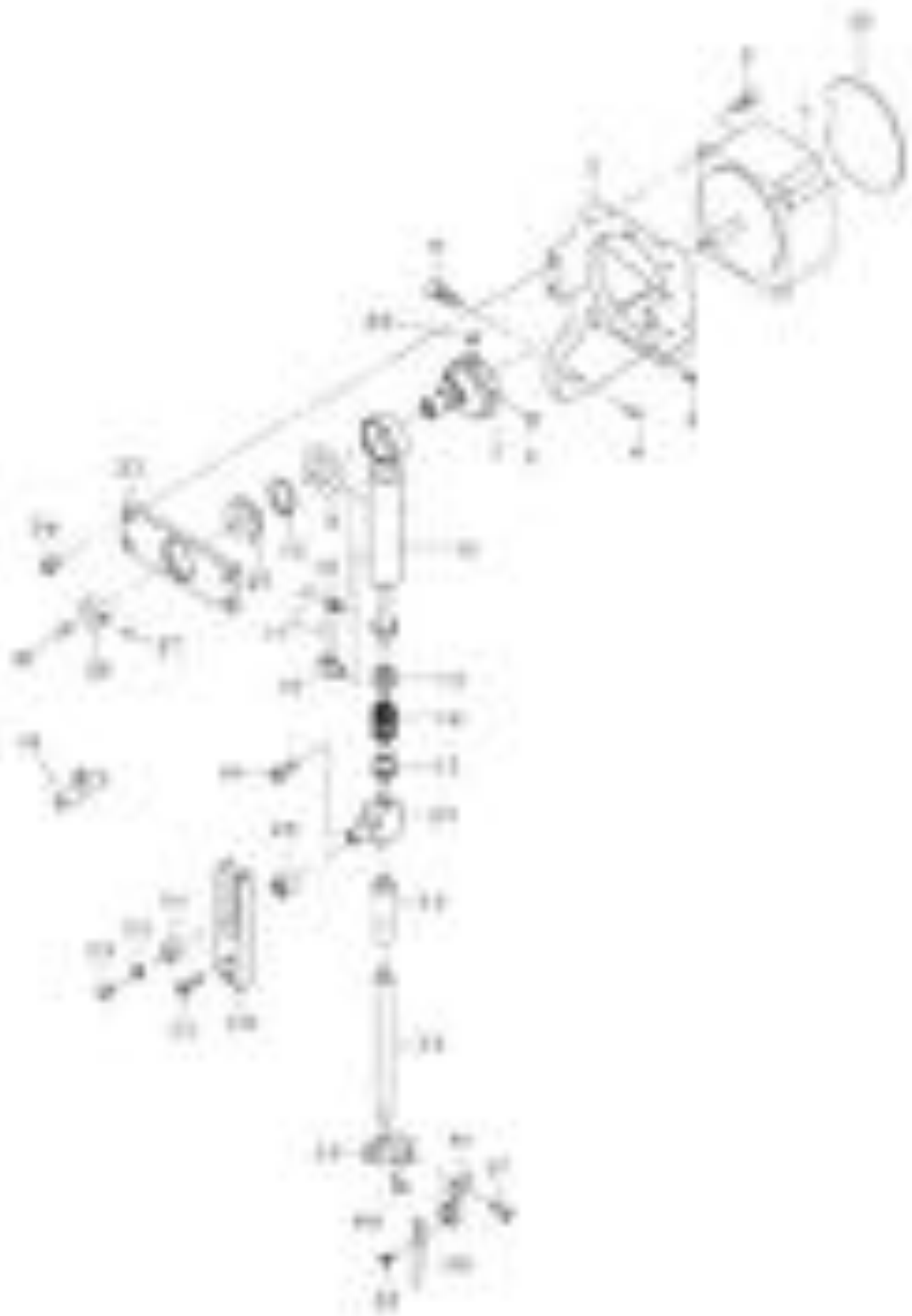

## 7、中刀组件/CENTER KNIFE COMPONENTS

序号 Ref.No.	公司件号 Part No.	名称	Description	数量 Amt.
1	42133001	中刀电机	MOTOR	1
2	S05087	螺钉M5x12	SCREW M5X10	4
3	42101005	电机底座	MOTOR BASE	1
4	S05028	螺钉M6x14	SCREW M6X14	2
5	42126004	定位销1	DOWEL PIN 1	1
6	42126003	定位销2	DOWEL PIN 2	1
7	42110001	偏心轮	KNIFE MOTOR CAM	1
8	421S14005	螺钉M4x6	SCREW M4X6.5	2
9	42124001	轴承	BEARING	1
10	H03034	轴用弹性挡圈16	RETAINING RING 16	1
11	42130008	中刀气缸	CENTER KNIFE AIR CYLINDER	1
12	42102057	气缸球接头1	CYLINDER BALL JOINT1	1
13	42102058	气缸球接头2	CYLINDER BALL JOINT2	1
14	42127013	连接弹簧	CONNECTING SPRING	1
15	42136007	弯管接头	HOSE ELBOW	1
16	40736048	接头	ELBOW UNION	1
17	61911001	气管	URETHANE HOSE BLACK	2
18	S05048	螺钉M4x10	SCREW M4X10	1
19	42130105	节流阀	THROTTLE VALVE	1
20	421S14005	螺钉M4x6	SCREW M4X6	1
21	42137029	中刀电机警告标识	WARM	1
22	421S10005	螺钉M3x0.5x6	SCREW M3X0.5X6	2
23	400923	轴承支撑板	BEARING PLATE	1
24	421S10010	螺钉M5X8	SCREW M5x8	4
25	B10015	轴承	BEARING	1
26	42108001	挡圈	THRUST COLLAR	1
27	421S10037	螺钉SM11/64x40X3.5	SCREW SM11/64x40X3.5	2
28	42103020	管套	PIPE SHROUD	1
29	42104003	中刀轴驱动块	KNIFE BAR CLAMP	1
30	42119008	中刀	KNIFE RIGHT	1
31	42109001	滑块	SLIDE BLOCK	1
32	421S10007	螺钉11/64-40X8	SCREW 11/64-40X8	1
33	42128017	垫圈4.8X8.4X0.8	WASHER 4.8X8.4X0.8	1
34	42109002	滑块座	SLIDE BLOCK GUIDE	1
35	421421S14005	螺钉M5x12	SCREW.M5X12.	2
36	42102006	中刀轴	KNIFE BAR	1
37	S01003	螺钉M4x12	SCREW M4X12	1
38	42103004	中刀轴下套	KNIFE BAR BUSHING	1
39	42104004	中刀支架A	KNIFE BASE A	1
40	S01003	螺钉M4x12	SCREW M4X12	1
41	42101006	中刀支架B	KNIFE BASE B	1
42	42122045	偏心轮孔塞	RUBBER PLUG	1



### 8、下轴组件/LOWER SHAFT COMPONENTS

序号 Ref.No.	公司件号 Part No.	名称	Description	数量 Amt.
1	12903011	旋梭基座轴套L	ROTARY HOOK BASE BUSH L	1
2	12923023	油毡	FELT	1
3	12903012	旋梭基座轴套R	ROTARY HOOK BASE BUSH R	1
4	12923023	油毡	FELT	1
5	4211000500	下轴光栅片组件	SENSOR SLIT ASM	1
6	42102055	下轴	LOWER SHAFT	1
7	421S14005	螺钉M4x6	SCREW M4X6	2
8	B10002	球轴承6004ZZNR	BALL BEARING 6004ZZNR	1
9	12903013	轴承套	BALL BEARING BUSH	1
10	S10020	螺钉M6x10	SCREW M6X10	1
11	42101114	电机座	MOTOR BASE	1
12	421S13057	螺钉M8X30	SCREW M8X30	2
13	W01010	垫圈M8	WASHER M8	2
14	B10009	球轴承6204ZZNR	BALL BEARING 6204ZZNR	1
15	12935004	同步轮D组件	TIMING PULLEY ASSY D	1
16	S10020	螺钉M6x10	SCREW M6X10	1
17	4213007800	联轴器	COUPLING	1
18	421S14024	螺钉M6X15	SCREW M6X15	4
19	42133007	交流电动机	AC SERVO MOTOR	1
20	421S13059	螺钉M5x20	BOLT M5x20	4
21	W02011	弹簧垫圈M8	SPRING WASHER M8	2
22	42112248	传感器固定座	SENSOR FIXING SEAT	1
23	40330010	光电传感器	PHOTO SENSOR	1
24	S05094	螺钉M3X8	SCREW M3X8	1
25	S09017	螺钉M6x10	SCREW M6X10	1
26	S10023	螺钉M6x10	SCREW M6X10	1

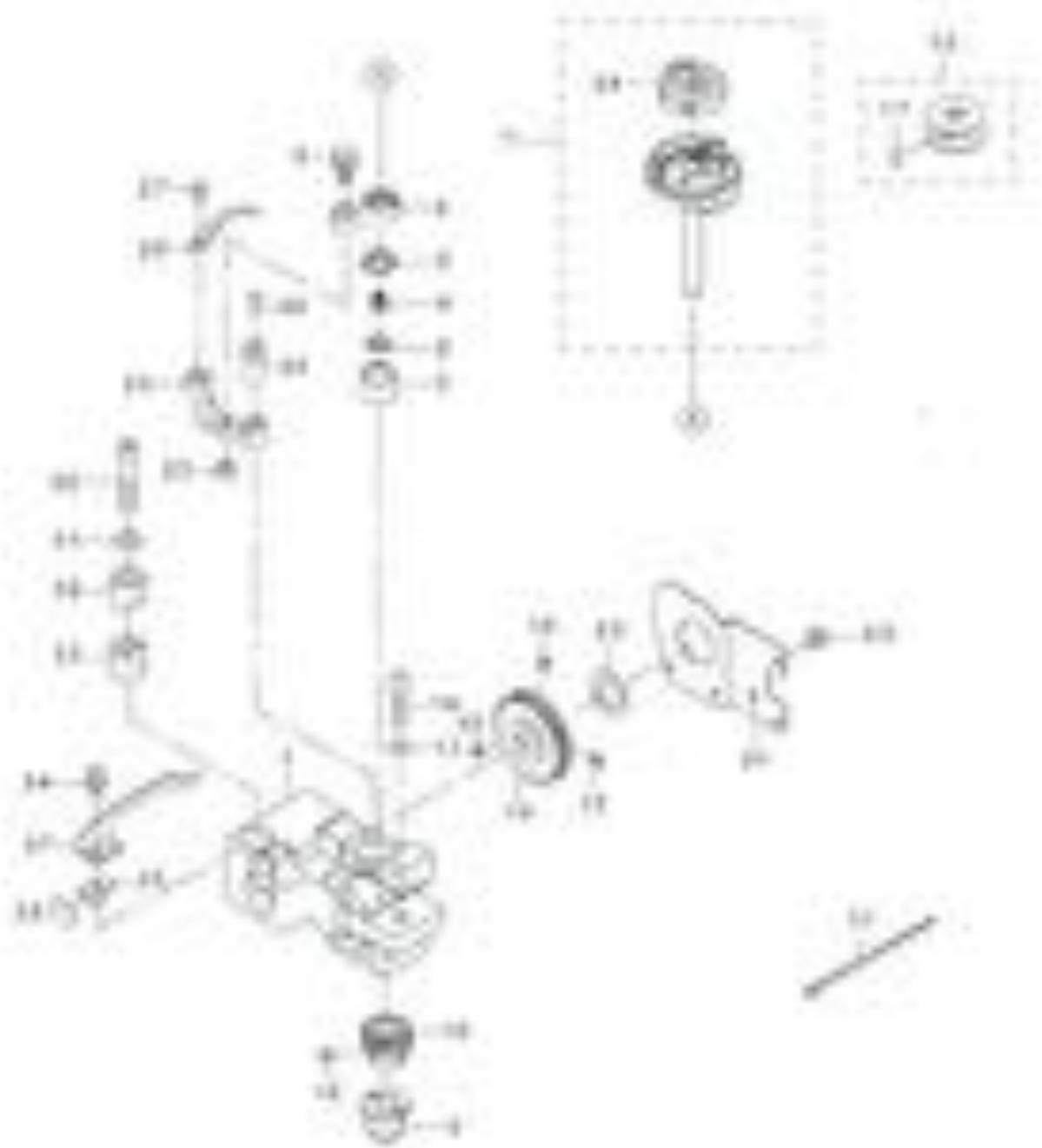

9、左旋梭组件/HOOK DRIVING SHAFT LEFT COMPONENTS

序号 Ref.No.	公司件号 Part No.	名称	Description	数量 Amt.
1	42101115	左梭架	LAGE HOOK SHAFT BASE L	1
2	11629004	止动圈	RETAINING RING	1
3	11803001	旋梭上轴套	THE HOOK SHAFT SLEEVE	1
4	11624004	滚针轴承	NEEDLE BRARING	1
5	12928005	轴向垫圈1.0MM	THRUST RING T=1.0MM	1
6	12905303	分线钩连杆	OPENER LINK	1
7	1291801600	旋梭组件	ROTARY HOOK ASSY	1
8	12902009	分线钩连杆轴	SHAFT OLINK	1
9	12903008	旋梭轴套D	ROTARY HOOK SHAFT BUSH	1
10	12925004	小齿轮	PINION GEAR	1
11	42137002	绑扎带	CABLE BAND	10
12	S08005	螺钉M6	SCREW M6	3
13	42128023	垫圈 M6	WASHER M6	1
14	S05084	螺钉M6X25	SCREW M6X25	1
15	S09033	螺钉M6X6	SCREW M6X6	2
16	42118002	大梭芯	ASSY BOBBIN	1
17	42130079	反光片	REFLECTION SHEET	1
18	S12003	螺钉M6X7	SCREW M6X7	1
19	12925003	大齿轮	SPIRAL GEAR	1
20	12928010	垫圈	SPECER	1
21	12912024	旋梭基座盖L	ROTARY HOOK BASE COVER L	1
22	S04037	螺钉M3X6	SCREW M3X6	4
23	N01004	螺母M5	NUT M5	1
24	42118001	梭壳	ASSY BOBBIN CASE	1
25	12926009	分线钩杆短轴	OLEVER SHAFT	1
26	12923018	油线	WICK	0.1
27	129S13003	螺钉SM3.57X8	SCREW SM3.57X8	1
28	11612014	分线钩	OPENER	1
29	12905304	分线钩杆	OPENER LEVER	1
30	129S11003	螺钉M6X25	SCREW M6X25	1
31	42128023	垫圈 M6	WASHER M6	1
32	12903009	套管A	PINCH SLEEVE A	1
33	12903010	套管B	PINCH SLEEVE B	1
34	421S13012	螺钉M4x10	SCREW	2
35	12923016	油毡	FELT	1
36	12912027	油毡架	FELT SUPPORT	1
37	42112231	左弹簧挡片	NIPPER SPRING L	1

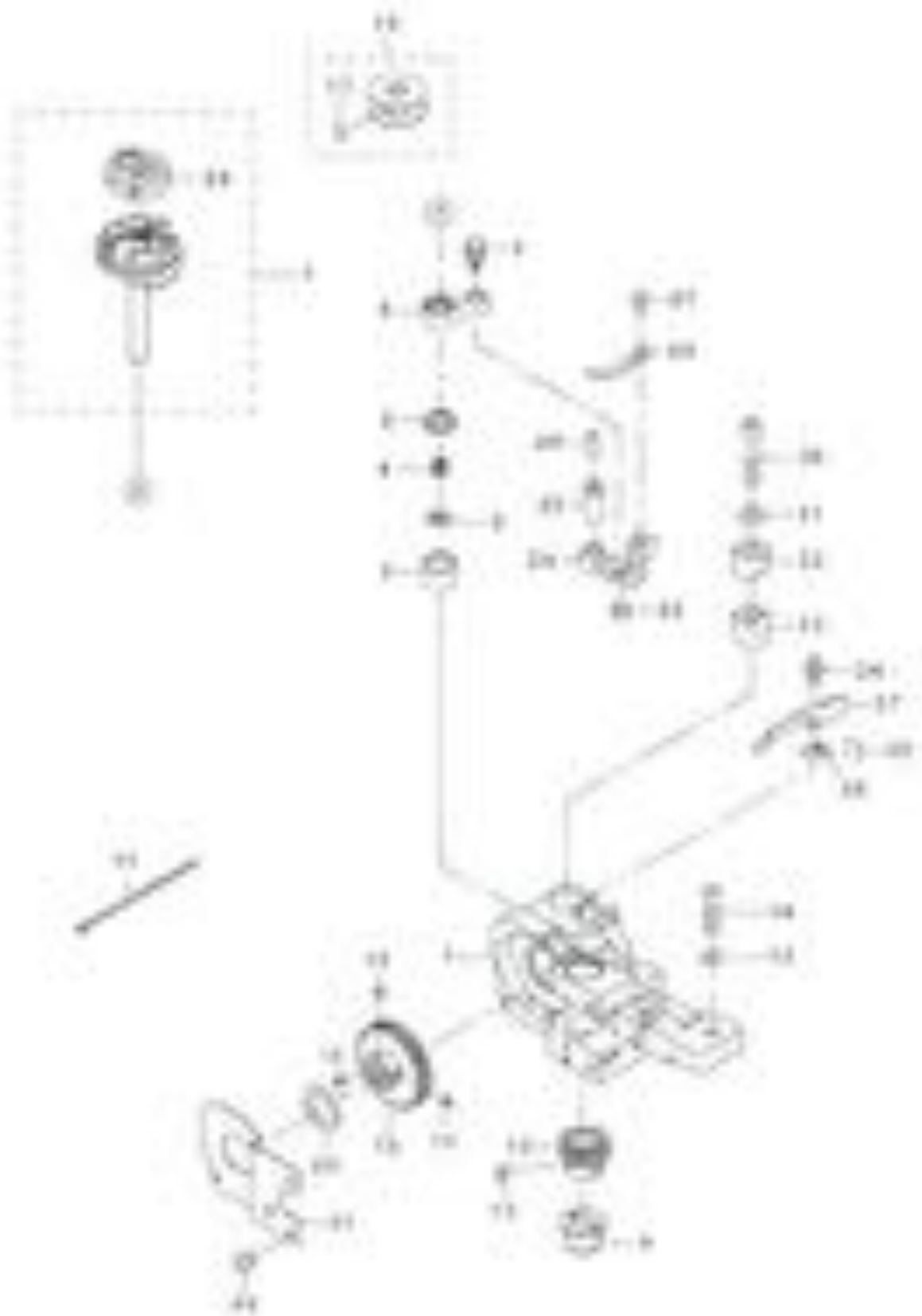



10、右旋梭组件/HOOK DRIVING SHAFT RIGHT COMPONENTS

序号 Ref.No.	公司件号 No.	Part	名称	Description	数量 Amt.
1	42101116		右梭架	LAGE HOOK SHAFT BASE R	1
2	11629004		止动圈	RETAINING RING	1
3	11803001		旋梭上轴套	THE HOOK SHAFT SLEEVE	1
4	11624004		滚针轴承	NEEDLE BRARING	1
5	12928005		轴向垫圈1.0MM	THRUST RING T=1.0MM	1
6	12905303		分线钩连杆	OPENER LINK	1
7	1291801600		旋梭组件	ROTARY HOOK ASSY	1
8	12902009		分线钩连杆轴	SHAFT OLINK	1
9	12903008		旋梭轴套D	ROTARY HOOK SHAFT BUSH	1
10	12925004		小齿轮	PINION GEAR	1
11	42137002		绑扎带	CABLE BAND	10
12	S08005		螺钉M6	SCREW M6	3
13	42128023		垫圈 M6	WASHER M6	1
14	S05084		螺钉M6X25	SCREW M6X25	1
15	S09033		螺钉M6X6	SCREW M6X6	2
16	42118002		大梭芯	ASSY BOBBIN	1
17	42130079		反光片	REFLECTION SHEET	1
18	S12003		螺钉M6X7	SCREW M6X7	1
19	12925003		大齿轮	SPIRAL GEAR	1
20	12928010		垫圈	SPECER	1
21	12912028		旋梭基座盖R	ROTARY HOOK BASE COVER R	1
22	S04037		螺钉M3X6	SCREW M3X6	4
23	N01004		螺母M5	NUT M5	1
24	42118001		梭壳	ASSY BOBBIN CASE	1
25	12926009		分线钩杆短轴	OLEVER SHAFT	1
26	12923018		油线	WICK	0.1
27	129S13003		螺钉SM3.57X8	SCREW SM3.57X8	1
28	11612014		分线钩	OPENER	1
29	12905304		分线钩杆	OPENER LEVER	1
30	129S11003		螺钉M6X25	SCREW M6X25	1
31	42128023		垫圈 M6	WASHER M6	1
32	12903009		套管A	PINCH SLEEVE A	1
33	12903010		套管B	PINCH SLEEVE B	1
34	421S13012		螺钉M4x10	SCREW	2
35	12923016		油毡	FELT	1
36	12912027		油毡架	FELT SUPPORT	1
37	42112232		右弹簧挡片	NIPPER SPRING R	1

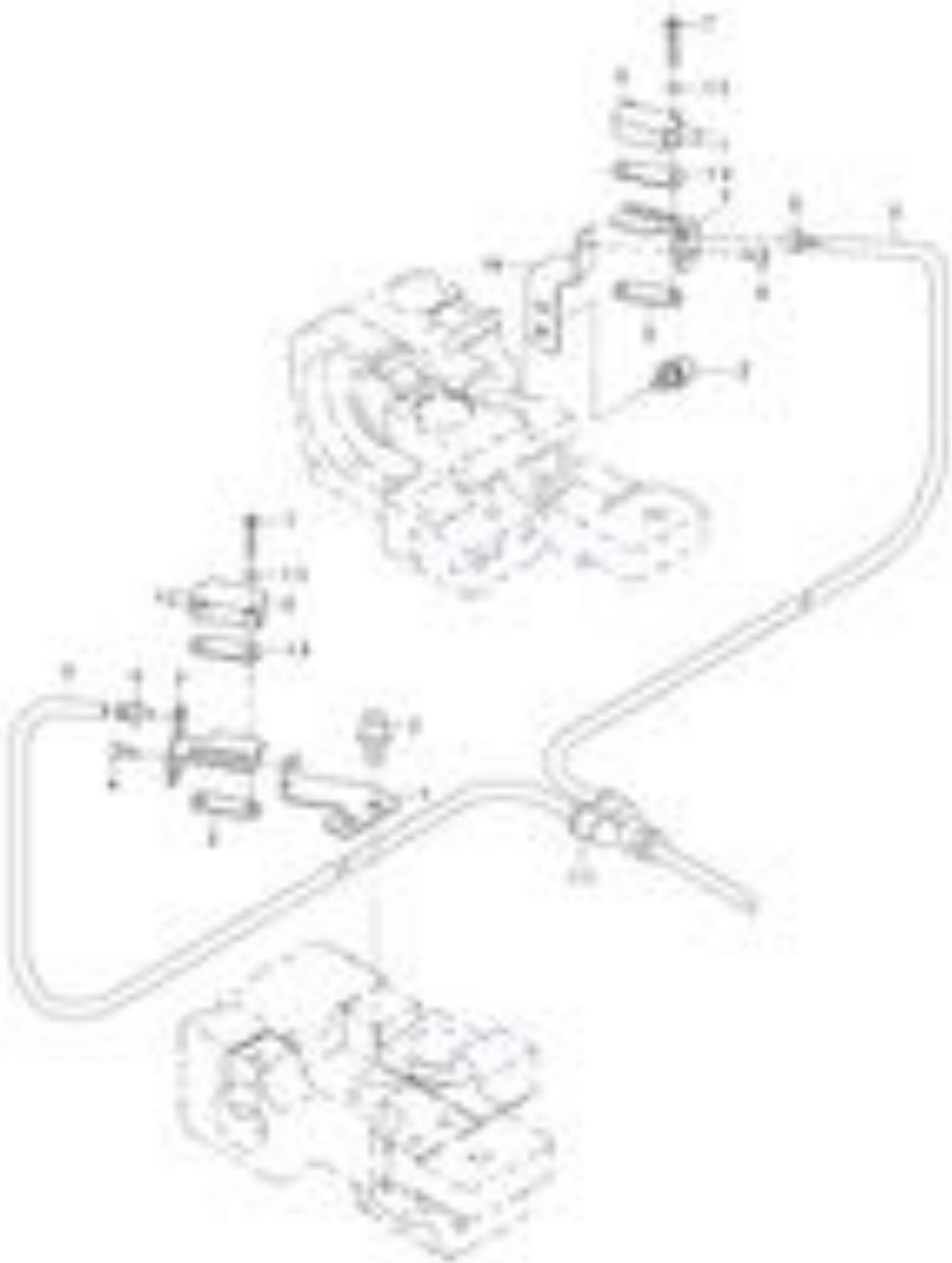

11、底线检测组件/BOBBIN THREAD DETECTING COMPONENTS

序号 Ref.No.	公司件号 Part No.	名 称	Description	数量 Amt.
1	42112019	左支架	FIBER BRACKET L	1
2	421S13012	螺钉M4x10	SCREW	4
3	42112020	支架B	FIBER BRACKET B	2
4	421S13013	螺钉M2.5x5	SCREW M2.5X5	2
5	42112021	支架C	FIBER BRACKET	2
6	42130025	袋盖传感器	FLAP SENSOR N ASM	2
7	421S10011	螺钉M2x12	SCREW M2X12	4
8	42136010	气管接头	CONNECTOR	2
9	61911001	气管	URETHANE HOSE BLACK	6
11	40736036	Y型气管接头	QUICK COUPLING	1
12	42112022	传感器安装板	FIBER BRACKET SPACER	2
13	42128018	垫圈M2	WASHER M2	4
14	42112237	右支架	FIBER BRACKET R	1

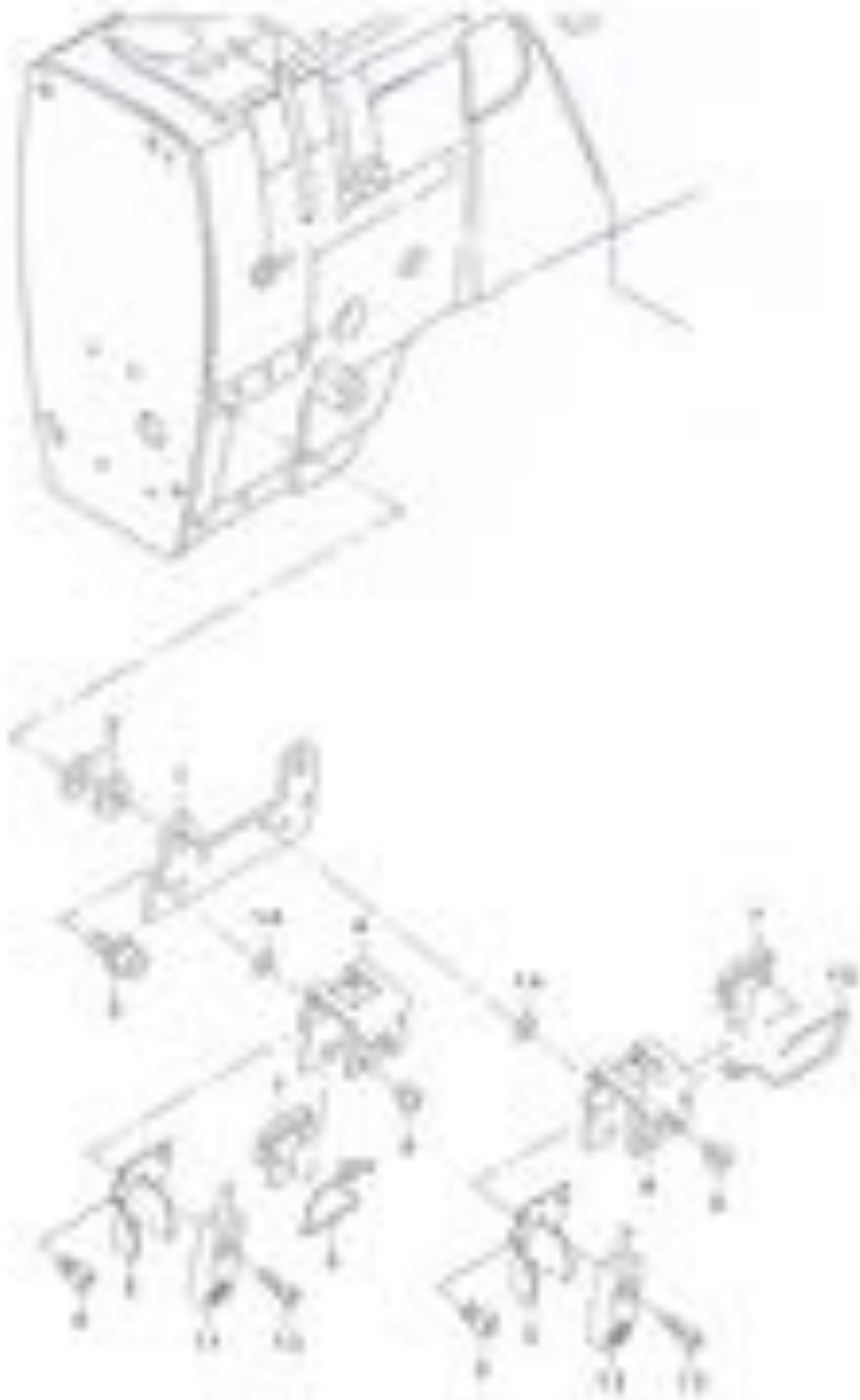

## 12、断线检测组件/THREAD DETECTING COMPONENTS

序号 Ref.No.	公司件号 Part No.	名称	Description	数量 Amt.
1	42112023	检测支架	DETECTING BASE	1
2	421S13012	螺钉M4x10	SCREW	2
3	42128003	垫圈	DETECTING SPACER	4
4	42112024	传感器支架	SENSOR BASE	2
5	42112025	传感器固定座	SENSOR GARDE	2
6	421S13038	螺钉M3x6	SCREW M3X6	4
7	42113006	过线环压板	DETECTING BAR GUIDE	2
8	421S10003	螺钉M3x4	SCREW	4
9	42113007	左过线环	DETECTING BAR L	1
10	42113008	右过线环	DETECTING BAR R	1
11	42130012	断线传感器	THREAD CHECK SENSOR ASM	1
12	42130012	断线传感器	THREAD CHECK SENSOR ASM	1
13	421S13015	螺钉M2.5x8	SCREW M2.5X8	2
14	42128019	垫圈 M3	WASHER M3	4

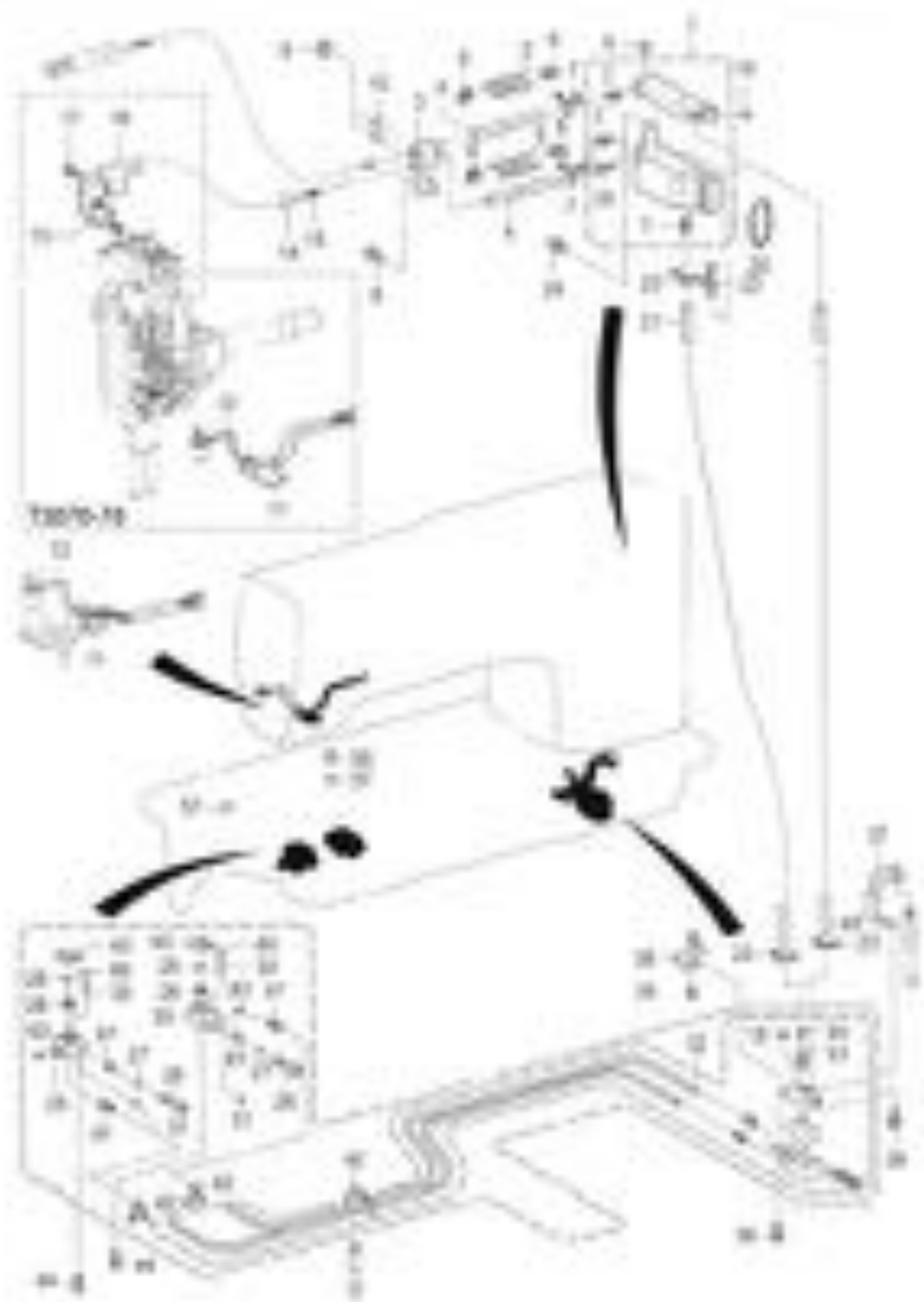

13、供油润滑装置/Lubrication COMPONENTS

序号 Ref.No.	公司件号 Part No.	名称	Description	数量 Amt.
1	12911004	油罐组件	OIL TANK ASSY	1
2	129S30009	油嘴管 8.6	OIL FEEDING PIPE 8.6	4
3	12936002	油管接头	OIL TERMINAL	1
4	12921006	维尼龙油管X135	OIL TUBE,L=135	2
5	12923009	油毡	FELT	4
6	12912334	线夹	CLIP	4
7	12912038	油管夹	TUBE CLIP	4
8	S04028	螺钉M5×8	SCREW M5X8	1
9	12922001	橡皮塞12.5	RUBBER CAP 12.5	4
10	12923010	油毡	ROTARY HOOK SHAFT FELT	2
11	1292301100	油毡组件	FELT ASSY	1
12	12912035	油毡压架	FELT SUPPORT	1
13	11211005	电线夹1.9×80	FASTENING BAND 1.9X80	3
14	12921005	油管X280	TUBEX280	1
15	12923019	油线 6×6X410	WICK 6X6X410	1
16	12912065	油管支架	TUBE SUPPORT	1
17	S04029	螺钉M5X12	SCREW M5X12	1
18	S05079	螺栓M8×12	BOLT SOCKET M8X12	1
19	41222006	橡皮塞8	RUBBER CAP 8	2
20	12922013	O形圈P38	O RING P38	1
21	12921003	维尼龙油管X210	OIL TUBEX210	1
22	12923019	油线X400	WICKX400	1
23	12912038	油管夹	TUBE CLIP	3
24	129S30016	螺栓(带垫圈)M5×10DB	SCREW PAN (S/P WASHER)M5X10	2
25	12901007	集油器L	OIL BLOCK L	1
26	129S20004	油量调整螺栓	OIL ADJUSTING SCREW	2
27	O01004	O形圈P4	O RING P4	2
28	12922007	橡皮垫片	RUBBER PACKING	2
29	12922008	旋梭轴垫片	ROTARY HOOK SHAFT FELT	2
30	12923012	油毡	OIL WICK	2
31	12922009	橡皮塞4.2	RUBBER CAP 4.2	2
32	12911005	副油罐组件	SUBTANK ASSY	1
33	12936004	油嘴管	OIL FEEDING PIPE	1
34	12922010	油门垫片	VALVE PACKING	1
35	12901008	集油器R	OIL BLOCK R	1
36	129S30017	螺栓(带垫圈)M4×8DA	SCREW PAN (S/P WASHER)M4X8	2
37	12912036	副油罐安装架A	SUBTANK SETTING PLATE A	1
38	12912037	副油罐安装架B	SUBTANK SETTING PLATE B	1
39	S04033	螺钉M6×8	SCREW PAN M6X8	2
40	12921003	维尼龙油管X242	OIL TUBEX242	1
41	12936003	油嘴管3.8	OIL FEEDING PIPE 3.8	4
42	12911006	油管固定夹	TUBE SUPPORT	1
43	12928011	旋梭台D垫片	ROTARY HOOK BASE D PACKING	2
44	S04039	螺钉M4×16	SCREW PAN M4X16	5
56	12922012	油盖	OIL CAP	1
57	12923030	油毡	FELT	2
60	12922008	旋梭轴垫片	ROTARY HOOK SHAFT FELT	2
61	12926013	柱塞	RUBBER PRESSER	2
62	12927020	油管夹	TUBE CLIP	4
63	12922016	橡皮塞6.3	RUBBER CAP 6.3	2





#### 14、倒缝组件/BACK TUCK COMPONENTS

序号 Ref.No.	公司件号 Part No.	名称	Description	数量 Amt.
1	42133002	步进电机	MARKING LIGHT MOTOR	1
2	421S11001	螺钉M3X12	SCREW M3X12	4
3	42101008	倒缝电机座架	PULSE MOTOR BASE	1
4	S05087	螺钉M5x12	SCREW M5X12	2
5	42101009	倒缝电机轴保护支架	BACK TACK BEARING PLATE	1
6	421S10012	螺钉M4X12	SCREW M4X12	4
7	42124003	轴承	BEARING	1
8	42128020	垫圈5.1x7.5x0.5	WASHER 5.1X7.5X0.5	2
9	42126003	定位销2	DOWEL PIN 2	1
10	42126004	定位销1	DOWEL PIN 1	1
11	42110002	偏心轴套	BACK TUCK CAM	1
12	421S14005	螺钉M4X6	SCREW M4X6	2
13	42105005	连杆	BACK TUCK LINK	1
14	42124004	轴承	BEARING	1
15	400732	摆轴连杆	BACK FEED ARM	1
16	42128014	垫圈	WASHER	4
17	S05094	螺钉M3X8	SCREW M3X8	1
18	S09042	螺钉M3x4	SCREW M3X4	2
19	42102011	连接轴D	DRIVING PIN D	1
20	S10006	螺钉M5x6	SCREW M5X6	2
21	S05028	螺钉M6x14	SCREW M6X14	1
22	40330010	光电传感器	PHOTO SENSOR	1
23	42112026	光电传感器安装板	PHOTO SENSOR PLATE	1
24	421S10014	螺钉M4X6	SCREW M4X6	2
25	4211000300	光栅片组件	SENSOR SLIT ASM	1

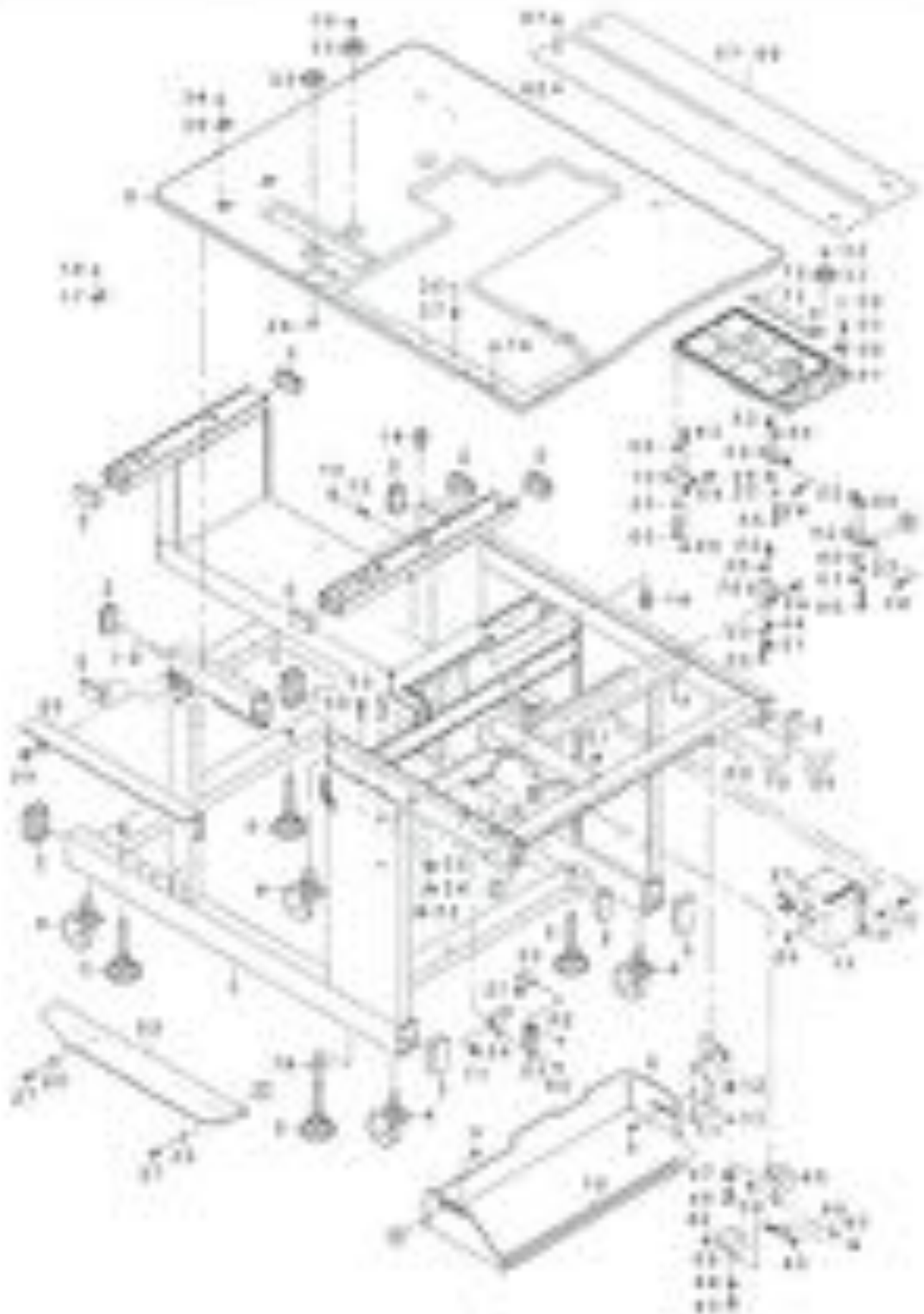

15、机架和台板组件/MECHANISM COMPILATION FRAME & COVER COMPONENTS(1)

序号 Ref.No.	公司件号 Part No.	名称	Description	数量 Amt.
1	301787	机架	FRAME	1
2	40711013	橡胶塞	CAP	10
3	42122004	大橡胶塞	CAP LARGE	4
4	42132001	脚轮	CASTER	4
5	42132002	可调高度支撑轮	ADJUST BOLT	4
6	42132003	台板	MAIN TABLE	1
7	421S30002	木螺钉4.5x16	WOOD SCREW D=4.5X16	14
8	42132004	衬布盘	BOX PLATE	1
9	421S10013	螺钉M5X8	SCREW M5X8	4
10	42122005	衬布盘橡胶	BOX PLATE RUBBER	1
11	42112027	主电源支架	MAIN SWITCH BRACKET	1
12	421S13017	螺钉M5x10	BOLT	2
13	421S10014	螺钉M4X6	SCREW M4X6	2
14	421S13018	螺钉M8x20	SCREW M8X20	3
15	61807032	间隔	SPACER	8
16	421S11003	螺钉M3X8	SCREW M3X8	8
17	61910021	线夹	CABLE CLAMP	7
18	S05115	螺钉M4x6	BOLT	7
19	42112028	安全罩	INT COVER	1
20	421S11003	螺丝M3X8	SCREW M3X8	4
21	61910013	线套	BUSHING L	0.13
22	42112029	扩展板	SUB TABLE	1
23	42128015	垫圈	WASHER	8
24	421S17001	螺钉M4X12	SCREW M4X12	1
25	42128015	垫圈	WASHER	4
27	S05067	螺钉M5x10	BOLT	4
28	42112030	收衣架扩展板	STACKER FLAT PLATE	1
29	421S13017	螺钉M5x10	BOLT	4
30	4211203100	滑动板定位组件	PIVOT PLATE	2
31	421S10015	螺钉M3X8	SCREW M3X8	4
32	42126006	定位销	POSITION PIN	2
33	4213001500	磁铁组件	MAGNET	4
34	421S30004	木螺钉3.8x13	WOOD SCREW D=3.8X13	4
35	421S10015	螺钉M3X8	SCREW M3X8	2
36	42130016	磁铁	BU MAGNET	2
37	421S30005	木螺钉3.5x16	WOOD SCREW D=3.5X16	2
38	42101010	滑动板定位块C	PIVOT PLATE C	2
39	421S30006	木螺钉2.7x13	WOOD SCREW D=2.7X13	1
40	42126007	滑动板定位销	POSITION BOSS	2
41	421S17002	螺钉M4X8	SCREW M4X8	2
42	42112032	气弹簧机头支架	GAS SPRING BRACKET	1
43	S05028	螺钉M6x14	SCREW M6X14	2
44	42128023	垫圈 M6	WASHER M6	2
45	42112033	气弹簧底座支架	GAS SPRING BRACKET	1
46	421S13022	螺钉M8X16	BOLT M8X16	3
47	W01010	垫圈M8	WASHER M8	3
48	42127002	气弹簧	GAS SPRING A	1
49	421S20006	轴位螺钉	SHOULDER SCREW	2
50	N01004	螺母M5	NUT M5	2

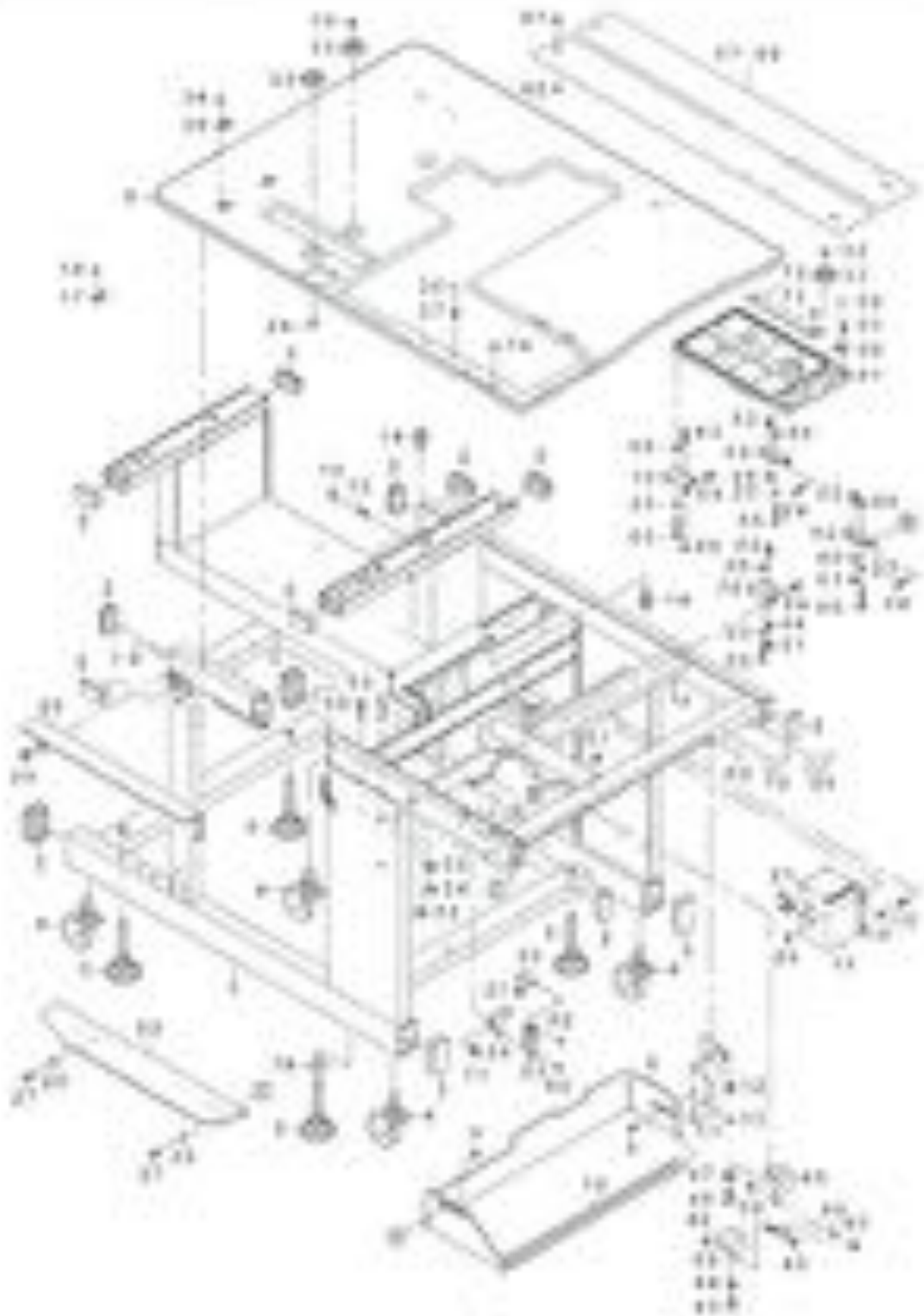

51	407S16008	帽形螺母M5	NUT M5	4
52	421S3000700	机头限位螺栓组件	STOPPER BOLT	2
53	42126008	机头导柱	HEAD GUIDE PIN	1
54	N01008	螺母M8	NUT M8	1
55	W01010	垫圈M8	WASHER M8	1
56	42112034	铰链头支架	CLIP BRACKET	1
57	421S13003	螺钉M4x8	SCREW M4x8	2
58	42112035	铰链座支架	CLIP BRACKET	1
59	42131001	铰链	CATCH CLIP	1
60	421S10016	螺钉	SCREW	4
61	400924	吸风盘	SUCTION BOX	1
62	42112036	吸风盘支架(右)	SUCTION BOX BRACKET R	2
63	421S30008	吸风盘高度调节螺栓	SUCTION BOX ADJUST BOLT	4
64	S05004	螺钉M5X14	HEXAGONAL-HOLE BOLT M5X14	8
65	S05083	螺钉M5X30	SCREW M5X30	8
66	N01004	螺母M5	NUT M5	12
67	4211203700	滑动板8 -14	SEWNING TABLE UNIT 8 -14	1
68	4211203800	滑动板16-20	SEWNING TABLE UNIT 16-20	1
71	421S13017	螺钉M5x10	BOLT	2
72	42112039	衬布支撑板	SUCTION SUPPORT PLATE	1
73	421S17002	螺钉M4X8	SCREW M4X8	2
74	N01003	螺母M16	NUT M16	4
75	42112238	吸风盘支架(左)	SUCTION BOX BRACKET L	2
76	W01014	垫圈M16	WASHER M16	

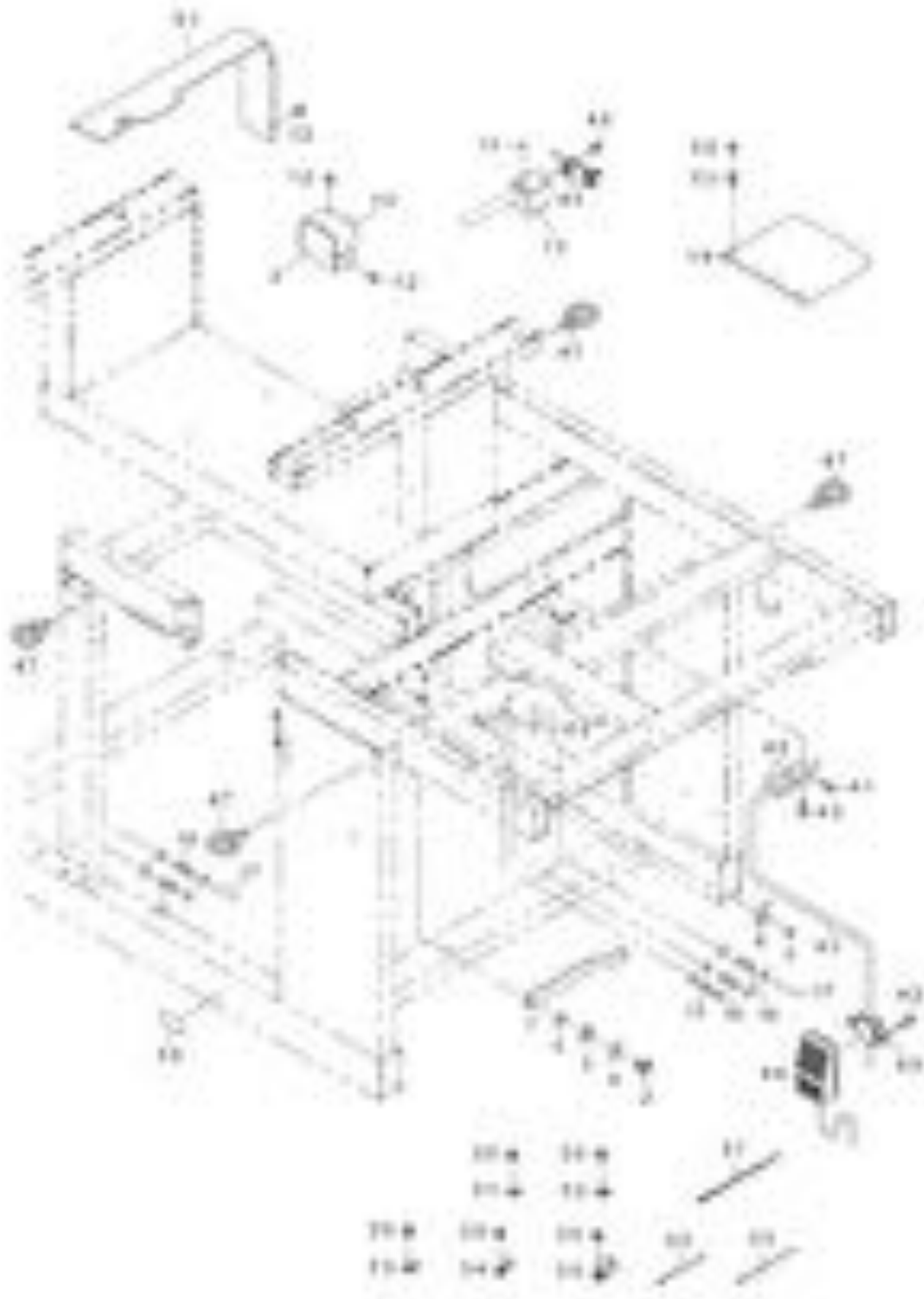

16、机架和台板组件(2) /MECHANISM COMPILATION FRAME &COVER COMPONENTS(2)

序号 Ref.No.	公司件号 Part No.	名称	Description	数量 Amt.
1	42112040	机头支撑杆	ROCK BAR	1
2	421S20007	轴位螺钉	SHOULDER SCREW	1
3	42128025	垫圈10.2x18x1	WASHER 10.2X18X1	1
4	42128025	垫圈10.2x18x1	WASHER 10.2X18X1	1
5	42128027	波纹垫圈10.5x14.5x0.3	WAVED WASHER 10.5X14.5X0.3	2
6	42112041	机头支撑杆挡板	ROCK BAR SUPPORT PLATE	1
7	S05067	螺钉M5x10	BOLT	2
8	S05067	螺钉M5x10	BOLT	1
9	301833	中刀罩壳1	KNIFE SHELL1	1
10	301834	中刀罩壳2	KNIFE SHELL2	1
11	421S14005	螺钉M4X6	SCREW M4X6	1
12	421S10022	螺钉M4X6	SCREW M4X6	9
13	400926	急停开关连接板	SWITCH ASM.	1
14	42112042	绕线器盖板	MOTOR COVER	1
15	40736034	带螺纹气管转接头4	UNION	1
16	40736035	带螺纹气管转接头6	UNION	4
17	42136017	堵头6	PLUG	2
40	400925	脚靠安装块1	NEE SWITCH BASE 1	2
41	421S10019	螺钉M5X14	SCREW M5X14	4
42	421S10009	螺钉M5X16	SCREW M5X16	6
43	42102012	脚靠轴	SWITCH SHAFT	1
44	40730002	脚踏开关	NEE SWITCH ASSY	1
45	4213001800	紧急停车开关	SWITCH ASM.	1
46	421S13003	螺钉M4x10	BOLT	2
47	421S30012	吊环M12	EYE BOLT M12	4
48	400734	脚靠安装块2	NEE SWITCH BASE 2	1
51	61910018	线夹	CABLE CLAMP	3
52	61910019	线夹	CABLE CLAMP	5
53	61910020	线夹	CABLE CLAMP	6
54	61910021	线夹	CABLE CLAMP	6
55	61910022	线夹	CABLE CLAMP	1
56	421S11008	螺钉M4X10	SCREW M4X10	21
57	42137002	绑扎带	CABLE BAND	3
58	42137002	绑扎带	CABLE BAND	40
59	42137002	绑扎带	CABLE BAND	20
60	42137014	重力点标签	GRAVITY SEAL	2
61	301980	中刀盖板	ARM COVER	1
62	421S11009	螺钉M4X6	SCREW M4X6	3
63	421S30014	定位螺钉	SPACER	3

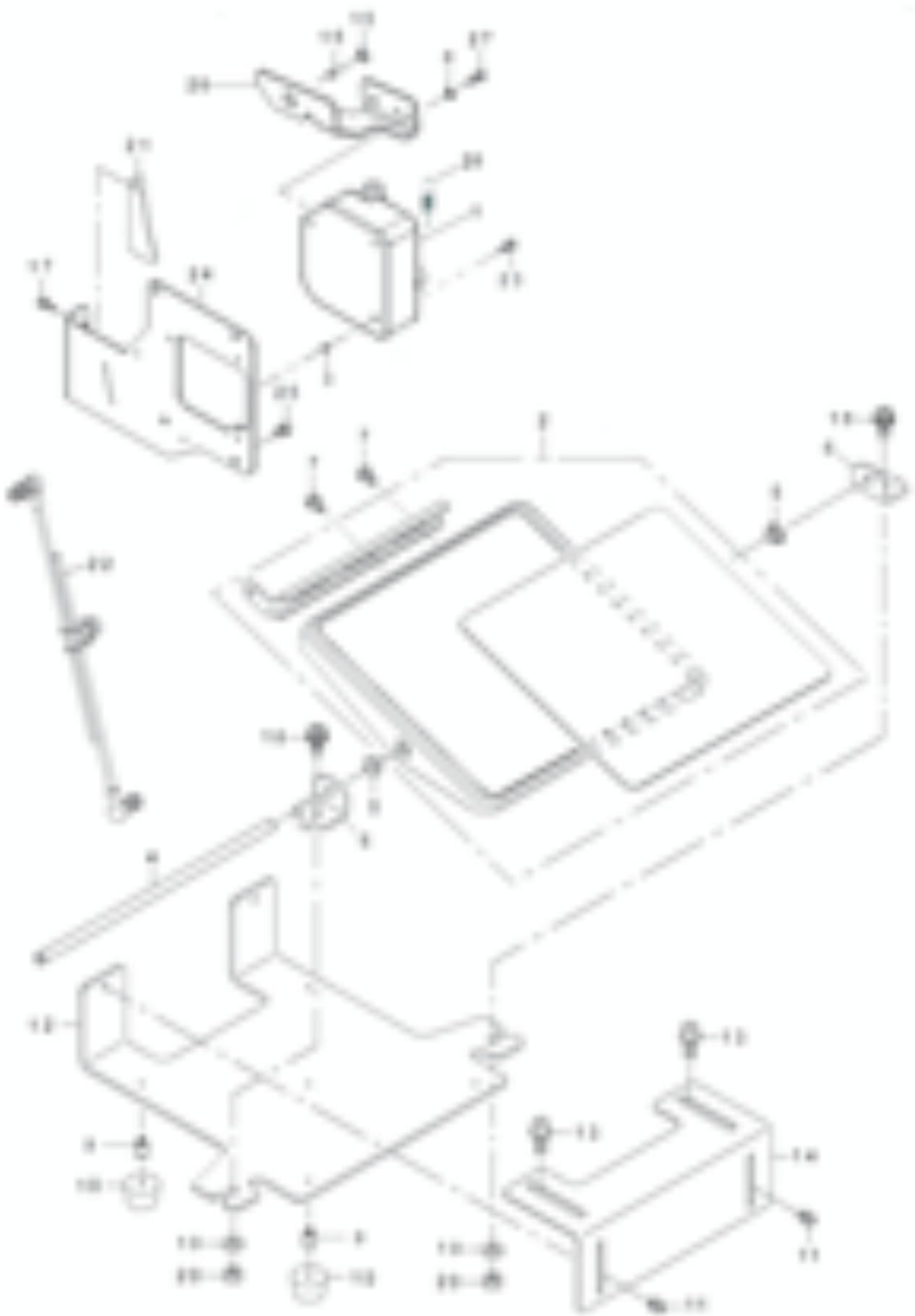



### 17、脚踏开关组件/PEDAL SWITCH COMPONENTS

序号 Ref.No.	公司件号 Part No.	名称	Description	数量 Amt.
1	808095	脚踏板组件	PEDAL SENSOR B ASM.	1
2	4213203600	大踏板组件	PEDAL ASM	1
3	42128032	垫圈4.8x11.5x2	WASHER 4.8X11.5X2	3
4	42102014	踏板轴	PEDAL SHAFT	1
5	42103006	踏板衬套	PEDAL BUSHING	2
6	42112054	踏板轴支架	PEDAL SHAFT BRACKET	2
7	421S12002	螺钉M6X12	BOLT M6X12	2
8	42128015	垫圈	WASHER	2
9	421S30027	橡胶支柱	SCREW	5
10	30122029	油盘减震垫	RUBBER LEGS RUBBER STUD	5
11	421S13017	螺钉M5x10	BOLT	2
12	42112051	踏板支撑板	PEDAL STAY	1
13	421S13018	螺钉M8x20	SCREW M8X20	2
14	42112050	机架脚踏安装板	PEDAL STAY	1
15	N01009	螺母M10	NUT M10	1
16	42102013	柱塞	PLUNGER	1
17	421S13012	螺钉M4x10	SCREW	2
18	421S12001	组合螺栓M8x20	WASHER HEXAGONAL BOLT	2
19	W01010	垫圈M8	WASHER M8	2
20	N01008	螺母M8	NUT M8	2
21	42112049	踏板导向板	PEDAL LEVER SPPORT GUIDE	1
22	42131002	连杆	CONNECTING ROD ASM.	1
23	421S13012	螺钉M4x10	SCREW	3
24	42112047	踏板安装板	PEDAL BASE	1
25	421S13017	螺钉M5x10	BOLT	4
26	4211204800	踏板加长支架组件	PEDAL LEVER BRACKET	1
27	S05087	螺钉M5x12	SCREW M5X12	2
28	42127014	踏板弹簧	SPRING	1

# T5878-78/688

16. 3D VIEW (TOP/LEFT SIDE)  
CORNER/END COMPONENTS FOR T5878

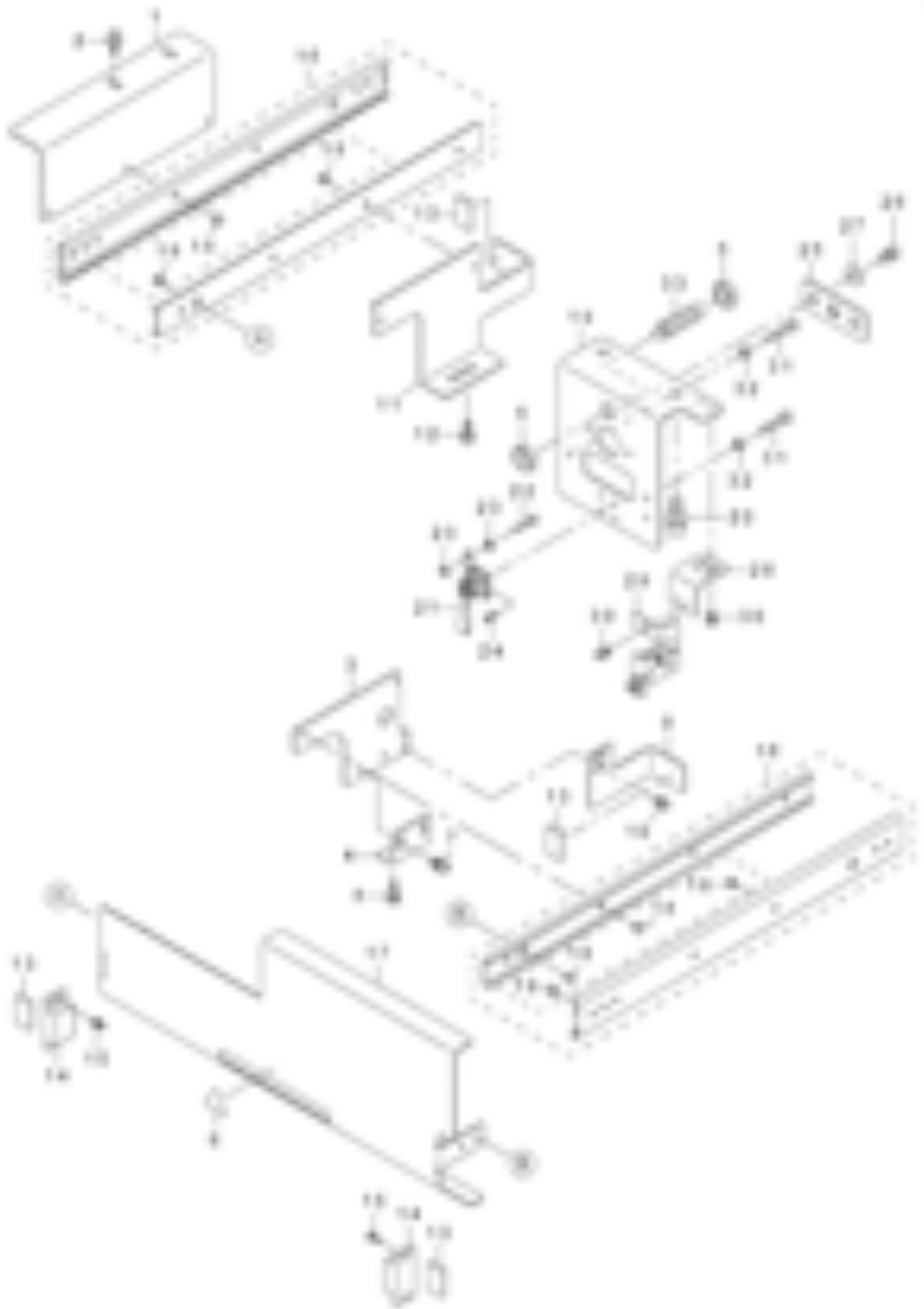

18、角刀组件(T5878-68B专用) /CORNER KNIFE COMPONENTS (FOR T5878-68B)

序号 Ref.No.	公司件号 Part No.	名称	Description	数量 Amt.
1	42112251	滑轨安装板	SLIDE BASE	1
2	421S13028	螺钉M5x14	SCREW M5x14	2
3	42112252	滑动支架A	SLIDE BRACKET A	1
4	42112253	滑动支架C	SLIDE BRACKET C	1
5	N01010	螺母M12	NUT M12	2
6	42137028	警告标示	CAUTION LABEL(25)	1
7	421S13017	螺钉M5x10	BOLT	2
8	421S13028	螺钉M5x14	SCREW M5x14	2
9	42112254	固定板	UNIT FIXED BKT	1
10	421S13003	螺钉M4x10	BOLT	2
11	42112255	滑动支架B	SLIDE BRACKET B	1
12	421S13028	螺钉M5x14	SCREW M5x14	2
13	42123003	衬垫	CUSHION	4
14	42130019	门吸	MAGNET CATCH	2
15	421S13053	螺钉M3x6	BOLT	4
16	4210900600	滑轨	SLIDE RAIL	2
17	42112060	角刀抽屉板	CORNER KNIFE UNIT COVER	1
18	421S13008	螺钉M4x4	SCREW	13
19	42112256	电磁阀安装板	FRAME BRACKET	1
20	421S13018	螺钉M8X20	SCREW M8X20	2
21	42131004	铰链	TOGGLE CLAMP	1
22	S05119	螺钉M4x18	SCREW M4X18	1
23	N01001	螺母M4	NUT M4	2
24	421S13019	螺钉M4x6	BOLT	4
25	42112074	导板	GUIDE PLATE	1
26	421S13027	螺钉M5x12	BOLT	2
27	42128036	垫圈	WASHER	2
28	42112257	安全开关支架	OPEN SENSOR BRACKET	1
29	1143002300	安全开关组件	HEAD DETECT SWITCH ASM	1
30	421S13003	螺钉带垫M4x8	BOLT	3
31	S05035	螺钉M5X25	HEXAGONAL-HOLE BOLT	2
32	N01004	螺母M5	NUT M5	2
33	42127006	弹簧柱塞	SPRING PLUNGER	1

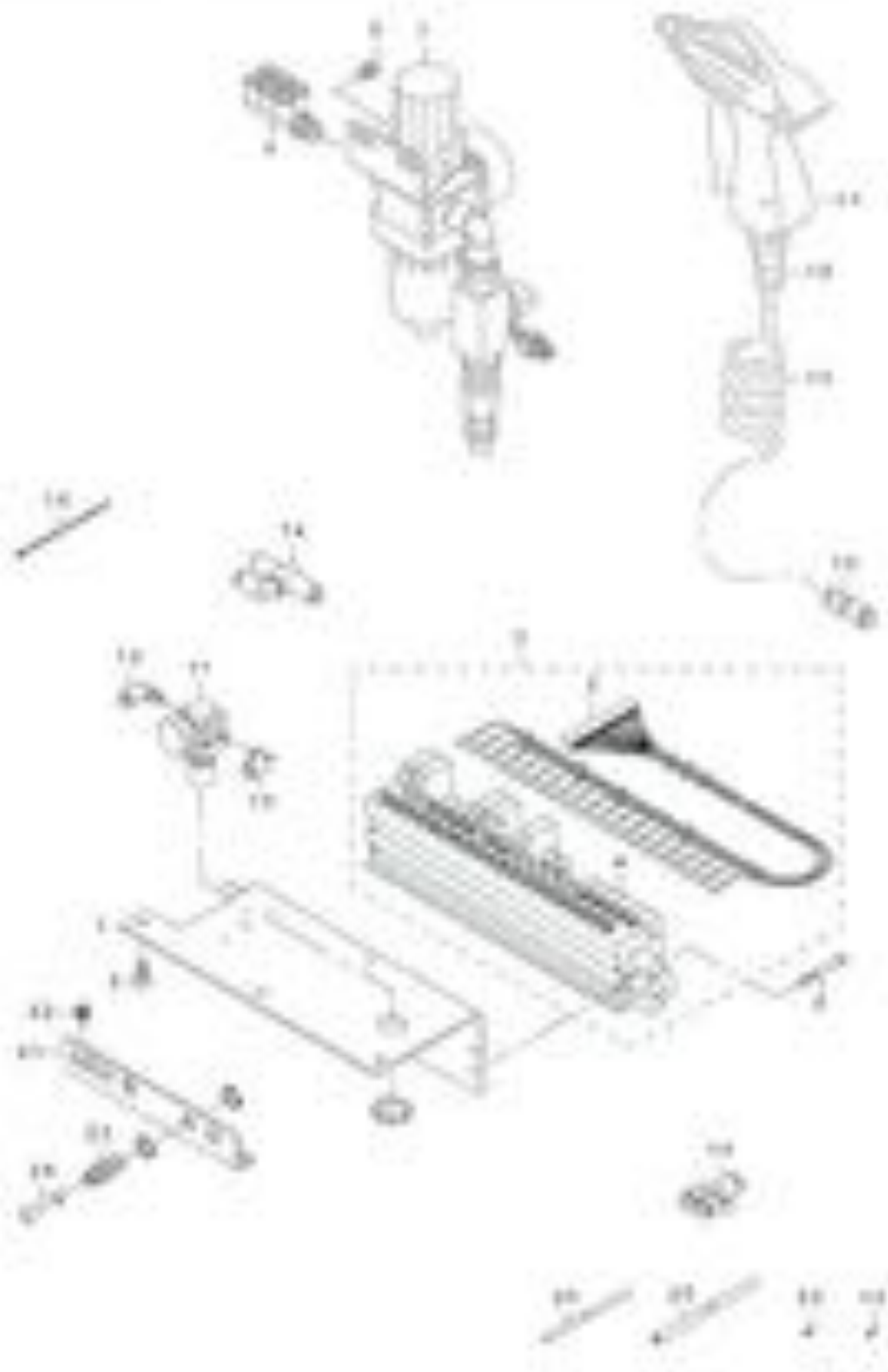

19、气动组件/AIR EQUIPMENT COMPONETS

序号 Ref.No.	公司件号 Part No.	名 称	Description	数量 Amt.
1	42112235	安装板	MANIFOLD VALVE BASE	1
2	S05033	螺钉M6X12	BOLT	3
3	4213009300	电磁阀组件	MANIFOLD ASSY	1
4	4213009400	电磁阀组件	MANIFOLD VALVE ASSY	1
5	62800016	电线	AIR SORENOID VALVE CORD	1
6	421S10036	螺钉M4X25	SCREW M4X35	4
7	4213008800	过滤器	FILTER REGULATER ASM.	1
8	421S13017	螺钉M5x10	BOLT	2
9	42136018	六分插头	TRIPLE BRANCH UNIVERSAL ELBOW	1
10	42136024	气管插头	STRAIGHT UNION	1
11	42130102	气枪	AIR GUN	1
12	40736018	气管接头	HALF UNION 6XPT1/4	1
13	42130103	螺旋管	COIL TUBE	1
14	42130087	梭阀	SHUTTLE VALVE	1
15	42121004	插入环(小)	INSERT RING	4
16	42137002	绑扎带	CABLE BAND	20
17	40730090	调压阀	AIR REGULATOR	1
18	42136001	弯型接头	ELBOW UNION	2
19	42136015	Y接头	Y UNION	3
20	42121004	插入环(小)	INSERT RING	2
21	42112236	滚布轮插头支架	PLUG BRACKET	1
22	421S11008	螺钉M4X10	SCREW M4X10	3
23	42136016	带螺纹气管转接头6	UNION	1
24	42136017	堵头6	PLUG	2
25	61911001	气管	URETHANE HOSE BLACK	50
26	61911002	气管	TUBE HOSE BLUE	50

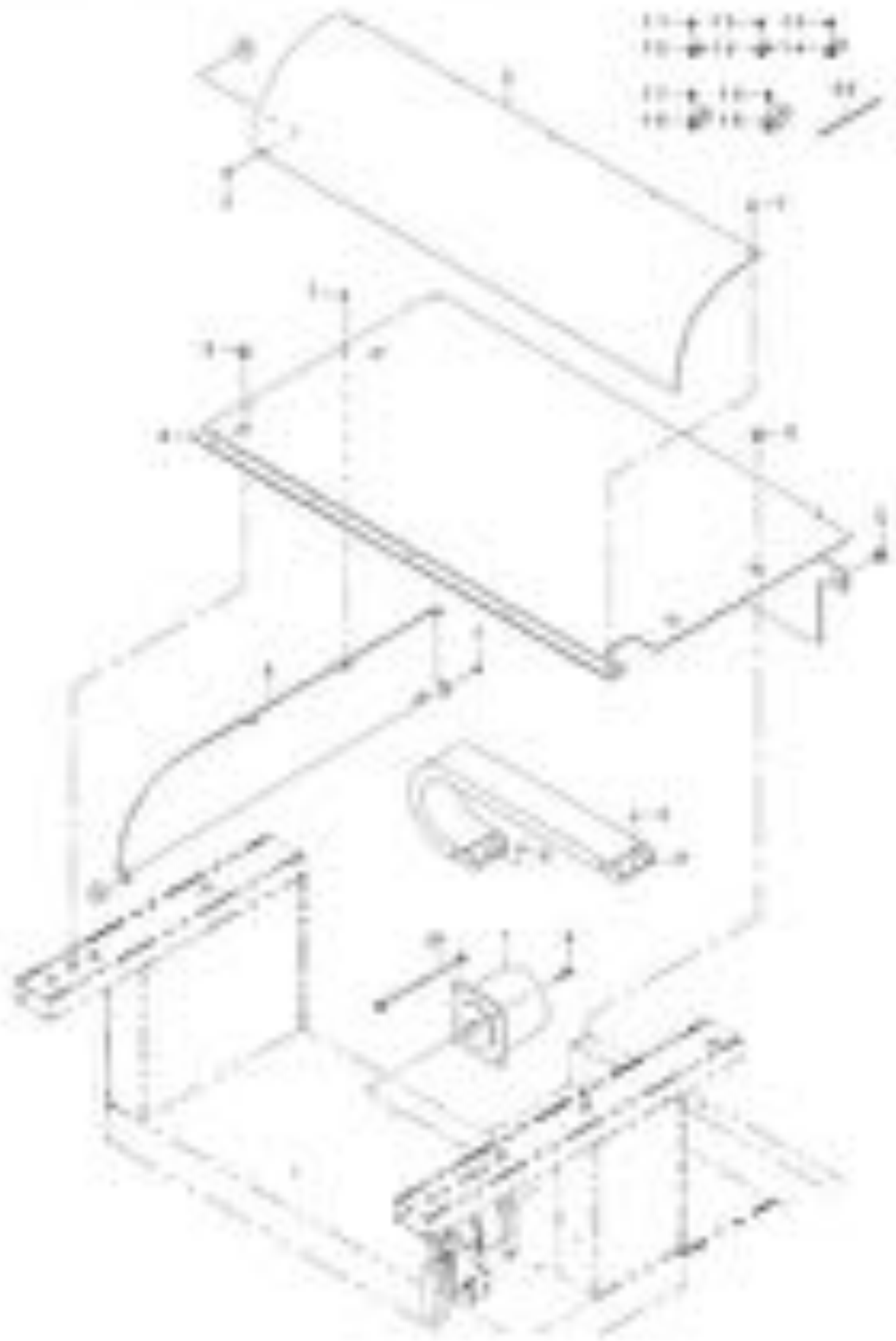

**20、盖板组件/CLAMP FOOT COMPONENTS**

序号 Ref.No.	公司件号 Part No.	名 称	Description	数量 Amt.
1	42133004	压脚电机	BIG PRESSER MOTOR	1
2	421S13059	螺钉M5x20	BOLT M5x20	4
3	42111008	有机玻璃板罩	CLAMP FOOT COVER	1
4	301979	盖板	CLAMP FOOT PLATE	1
5	421S10021	螺钉M8X10	SCREW M8X10	6
6	303878	后盖板	CLAMP FOOT PLATE	1
7	421S10022	螺钉M4X6	SCREW M4X6	10
8	42131003	拖链	CABLE BEARER	1
9	421S17003	螺钉M3X6	SCREW M3X6	8
10	61910018	线夹	CABLE CLAMP	5
11	421S11008	螺钉M4X10	SCREW M4X10	5
12	61910019	线夹	CABLE CLAMP	4
13	421S11008	螺钉M4X10	SCREW M4X10	4
14	61910020	线夹	CABLE CLAMP	2
15	421S11008	螺钉M4X10	SCREW M4X10	2
16	61910021	线夹	CABLE CLAMP	1
17	421S11008	螺钉M4X10	SCREW M4X10	1
18	61910022	线夹	CABLE CLAMP	1
19	421S11008	螺钉M4X10	SCREW M4X10	1
20	42137002	绑扎带	CABLE BAND	20
21	42130113	闭环电机编码器转接线	ENCODER TRANSIT LINE	1

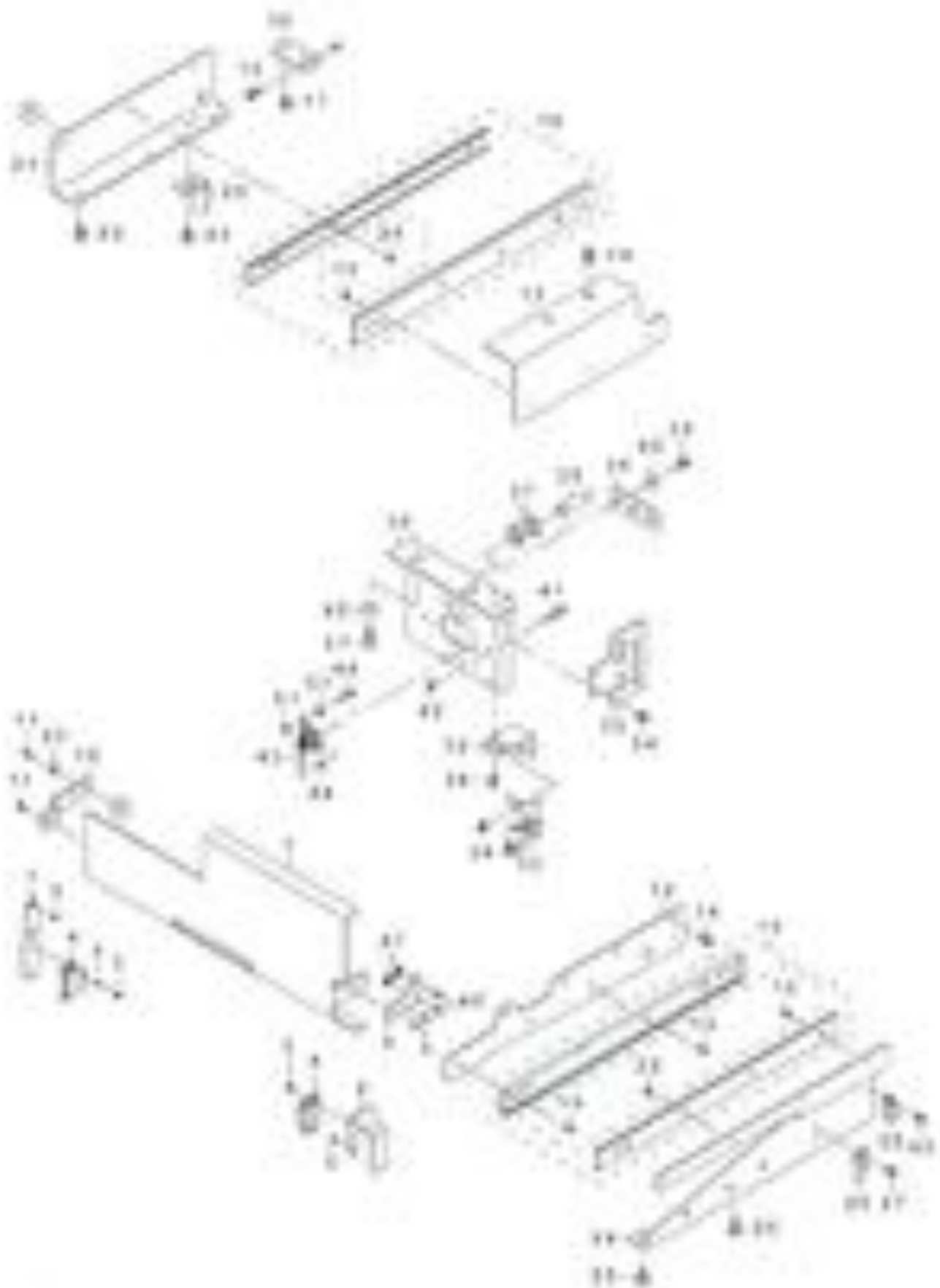



21、角刀组件/CORNER KNIFE COMPONENTS

序号 Ref.No.	公司件号 No.	Part	名称	Description	数量 Amt.
1	42112058		磁铁安装支架A	MAGNET PLATE A	1
2	42112059		磁铁安装支架B	MAGNET PLATE B	1
3	421S17003		螺钉M3X6	SCREW M3X6	4
4	42130019		门吸	MAGNET CATCH	2
5	421S11004		螺钉M3X5	SCREW M3X5	4
6	42128034		垫圈3.7X8X0.3	WASHER 3.7X8X0.3	2
7	301984		角刀抽屉板	CORNER KNIFE UNIT COVER	1
8	42112061		连接板A	COVER PLATE A	1
9	421S13026		螺钉M4x6	SCREW	2
10	42112062		连接板B	COVER PLATE B	1
11	421S13026		螺钉M4x6	SCREW	4
12	42112063		左滑轨安装板	SLIDE RAIL BASE L	1
13	42112064		右滑轨安装板	SLIDE RAIL BASE R	1
14	421S13027		螺钉M5x12	BOLT	6
15	421S12003		限位螺钉M5x16	STOPPER BOLT	1
16	42112065		底板	BASE PLATE	1
17	421S13017		螺钉M5x10	BOLT	2
18	4210900600		滑轨	SLIDE RAIL	2
19	421S13026		螺钉M4x6	SCREW	11
20	421S13008		螺钉M4x4	SCREW	3
21	42112066		左滑动支架	SLIDE BRACKET L	1
22	421S13028		螺钉M5x14	SCREW M5x14	3
23	42128035		垫圈4.3x12x1	PLAIN WASHER 4.3X12X1	2
24	42112067		右滑动支架	SLIDE BRACKET R	1
25	421S13029		螺钉M6x12	SCREW	2
26	42112068		右挡板	STOPPER PLATE R	1
27	421S13003		螺钉M4x10	BOLT	2
28	42112069		左挡板	STOPPER PLATE L	1
29	421S13028		螺钉M5x14	SCREW M5x14	2
30	42112070		电磁法安装板	FRAME BRACKET	1
31	421S13022		螺钉M8X16	BOLT M8X16	2
32	42112071		安全开关支架	OPEN SENSOR BKT	1
33	1143002300		安全开关组件	HEAD DETECT SWITCH ASM	1
34	421S13003		螺钉M4x10	BOLT	5
35	42112073		插头支架	PLUG BRACKET	1
36	42127006		弹簧柱塞	SPRING PLUNGER	1
37	N01010		螺母M12	NUT M12	2
38	42112074		导板	GUIDE PLATE	1
39	421S13027		螺钉M5x12	BOLT	2
40	42128036		垫圈	WASHER	2
41	S05035		螺钉M5X25	HEXAGONAL-HOLE BOLT	2
42	N01004		螺母M5	NUT M5	2
43	42131004		铰链	TOGGLE CLAMP	1
44	421S13019		螺钉M4x6	BOLT	4
45	W01010		垫圈M8	WASHER M8	2
46	421S13031		螺钉M4x10	SCREW	2
47	421S16001		垫块	ROLL	2
48	S05077		螺钉M4x18	SCREW M4X18	1
49	421S11008		螺钉M4X10	SCREW M4X10	1
50	61910021		线夹	CABLE CLAMP	1
51	N01001		螺母M4	NUT M4	2

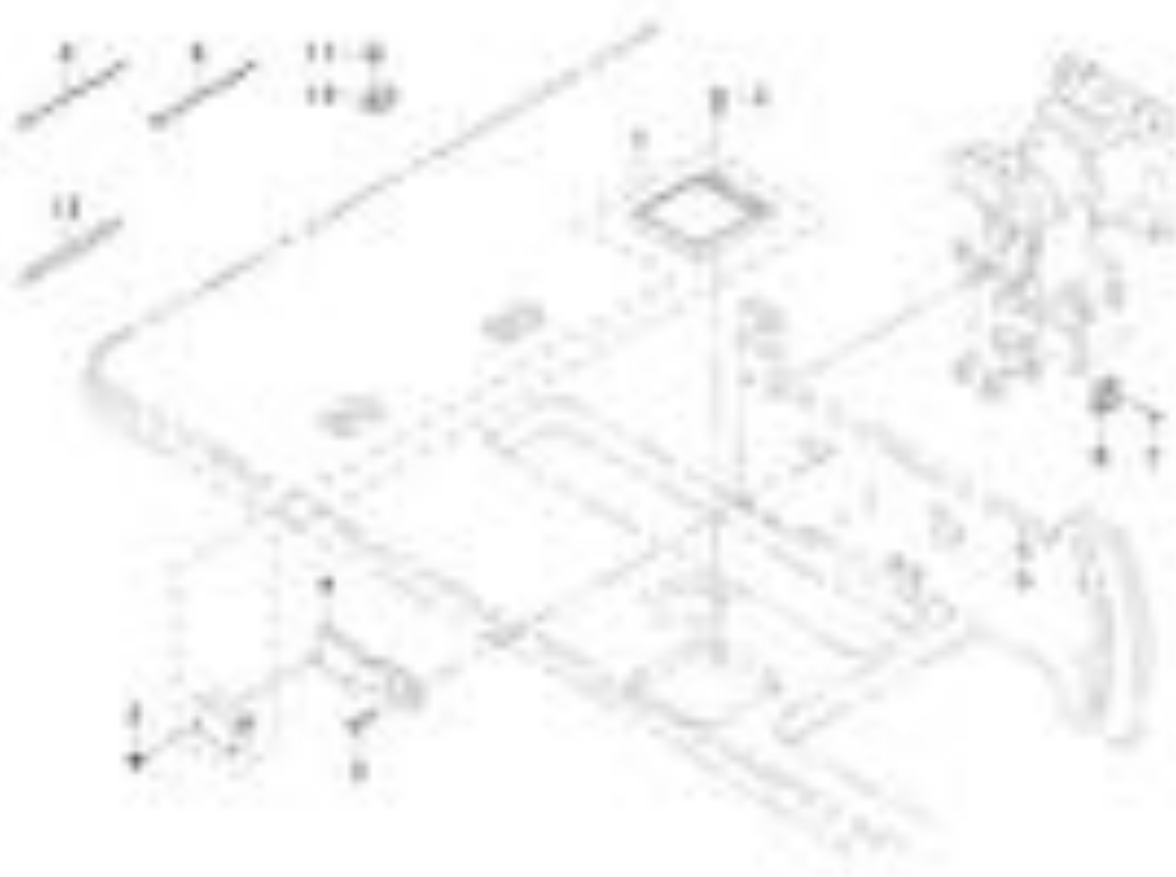

**22、测布组件/BINDER COMPONENTS**

序号 Ref.No.	公司件号 Part No.	名 称	Description	数量 Amt.
1	4213007300	反光板	SENSOR ASM	1
2	421S11002	螺钉M3X10	SCREW M3X 10	2
3	421S30004	木螺钉3.8x13	WOOD SCREW D=3.8X13	2
4	42112075	传感器固定板	SENSOR PLATE	1
5	S05067	螺钉M5x10	BOLT	2
6	61801002	微动开关SS-01	BINDER OPEN SWITCH ASM	1
7	421S13033	螺钉M2X8	SCREW M2X8	2
8	42137002	绑扎带	CABLE BAND	1
9	42137002	绑扎带	CABLE BAND	2
10	61910019	线夹	CABLE CLAMP	1
11	421S11008	螺钉M4X10	SCREW M4X10	1
12	61910028	螺旋管	SPIRAL TUBE	0.35

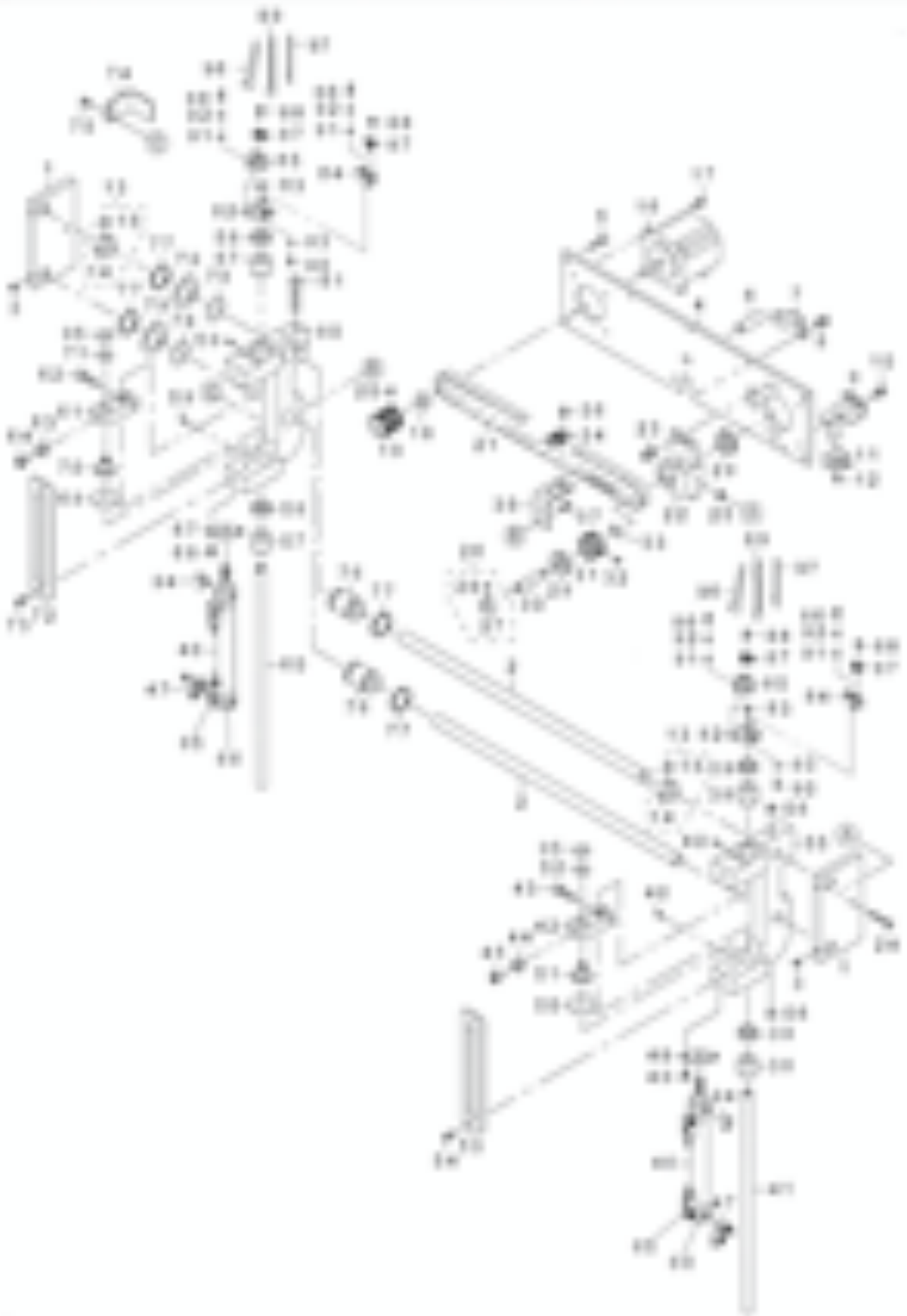

23、角刀组件(T5878-68B专用)/CORNER KNIFE UNIT(FOR T5878-68B)

序号 Ref.No.	公司件号 Part No.	名称	Description	数量 Amt.
1	400915	角刀纵板	BASE	2
2	42102059	滑轴	SLIDE SHAFT	2
3	S09008	螺钉M5x5	SCREW M5X6	4
4	400916	角刀横板	BASE A	1
5	S05129	螺钉M5x16	BOLT	4
6	400947	定位销	PIN 10X33	1
7	42112116	固定板	FIXED PLATE	1
8	421S13017	螺钉M5x10	BOLT	2
9	42112258	传感器支架	SENSOR BRACKET	1
10	421S13012	螺钉M4x10	SCREW	2
11	40330010	光电传感器	PHOTO SENSOR	1
12	421S10015	螺钉M3X8	SCREW M3X8	1
13	4210802000	挡圈组件	THRUST COLLAR ASM.	2
14	42108020	挡圈	THRUST COLLAR	1
15	S09008	螺钉M5x5	SCREW M5X6	2
16	42133006	角刀电机	CORNER KNIFE MOTOR	1
17	421S13012	螺钉M4x10	SCREW M4X10	4
18	42124017	轴承	BEARING	1
19	42135004	前角刀同步轮	DRIVE SPROCKET	1
20	S09010	螺钉M6X5	SCREW M6X5	2
21	42135006	同步带	TIMING BELT	1
22	42112114	角刀同步轮支架	CORNER KNIFE FEED BRACKET	1
23	421S13027	螺钉M5x12	BOLT	4
24	S05063	螺钉M4X25	SCREW M4X25	1
25	N01001	螺母M4	NUT M4	1
26	4210800700	挡圈组件	THRUST COLLAR ASM.	1
27	42108007	挡圈	THRUST HOLDER	1
28	421S14005	螺钉M4X6	SCREW M4X6	2
29	42124013	轴承	RADIAL BEARING	2
30	42102027	后角刀同步轮轴	LIFTING LEVER SHAFT	1
31	42135005	后角刀同步轮	DRIVEN SPROCKET	1
32	421S14005	螺钉M4x6	SCREW M4X6	1
33	H05013	卡簧6	E-RING 6	1
34	42112115	角刀同步带压块	BELT RECEIVER	1
35	42112259	角刀同步带固定板	BELT HOLDER	1
36	421S13019	螺钉M4x6	BOLT	2
37	421S13035	螺钉M4X8	SCREW M4X8	2
38	42103022	铜套	METAL	2
39	42122035	油封	DUST SEAL	2
40	421S14005	螺钉M4X6	SCREW M4X6	2
41	42102024	角刀轴	ELEVATING SHAFT	1
42	42101136	连杆	LIFTING BRACKET	1
43	S05071	螺钉M6X20	SCREW M6X20	1
44	42109007	滑块	ROLLER	1
45	421S20014	轴位螺钉	SHOULDER SCREW	1
46	42130037	气缸	AIR CYLINDER	2
47	42130032	节流阀	SPEED CONTROLLER	2
48	42112260	气缸固定板	CYLINDER BRACKET	1
49	S05048	螺钉M4x10	BOLT	2

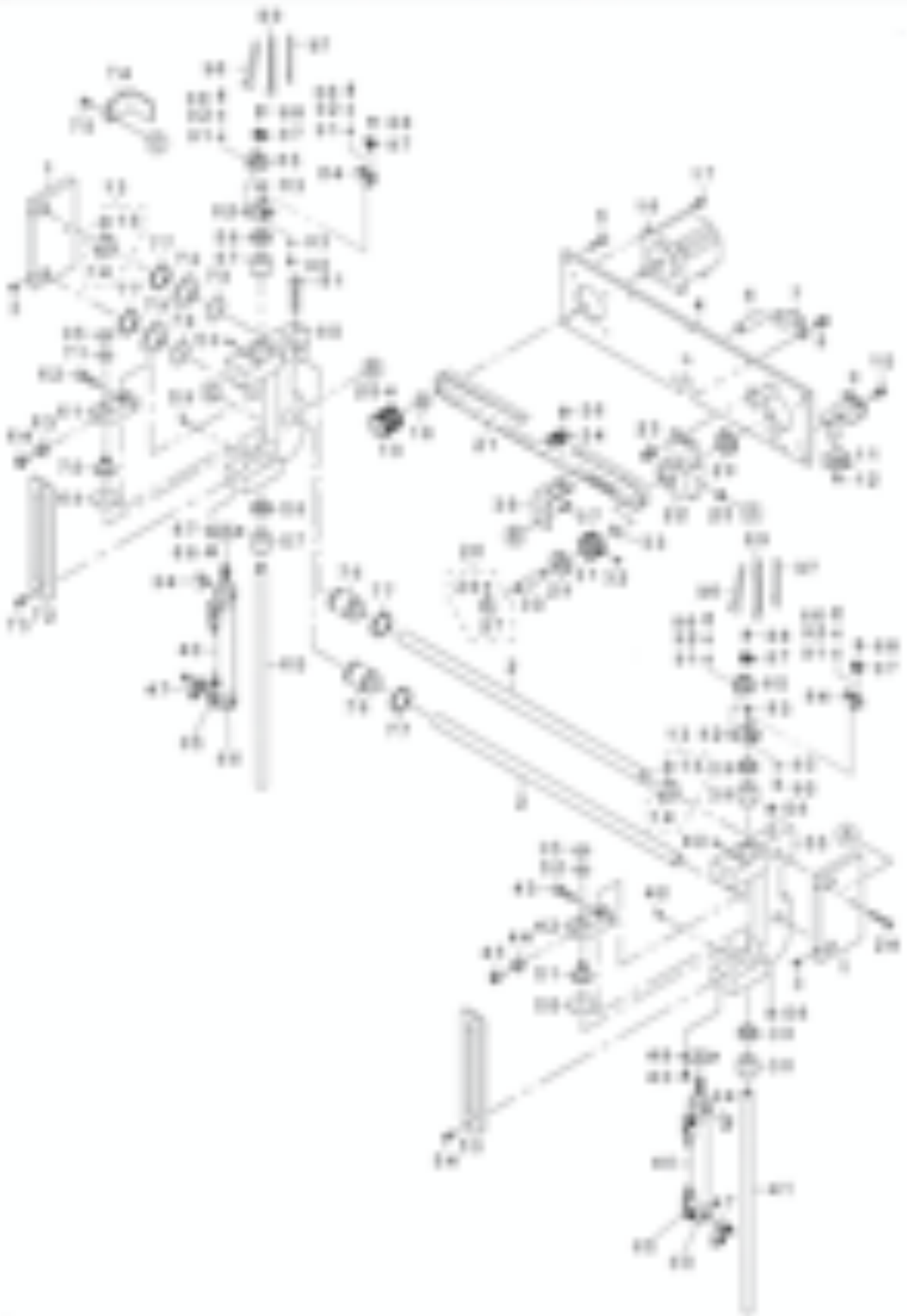

50	42122036	橡胶垫	CUSHION	1
51	42122037	气缸螺母	CYLINDER NUT	1
52	42128015	垫圈	WASHER	1
53	42112261	角刀导向支架	ELEVATING GUIDE PLATE	1
54	S05067	螺钉M5×10	SCREW M5×10	2
55	42101137	角刀支架	ELEVATING BRACKET	1
56	421S13028	螺钉M5×14	SCREW M6X8	2
57	42103022	铜套	METAL	2
58	42122035	油封	DUST SEAL	2
59	421S14005	螺钉M4X6	SCREW M4X6	2
60	42102024	角刀轴	ELEVATING SHAFT	1
61	42101136	连杆	LIFTING BRACKET	1
62	S05071	螺钉M6X20	SCREW M6X20	1
63	42109007	滑块	ROLLER	1
64	421S20014	轴位螺钉	SHOULDER SCREW	1
65	42130089	磁开关	MAGNETIC SWITCH	4
66	61300007	固定夹	FIXED CLAMP	4
67	42112260	气缸固定板	CYLINDER BRACKET	1
68	S05048	螺钉M4x10	BOLT	2
69	42122036	橡胶垫	CUSHION	1
70	42122037	气缸螺母	CYLINDER NUT	1
71	42128015	垫圈	WASHER	1
72	42112261	角刀导向支架	ELEVATING GUIDE PLATE	1
73	S05067	螺钉M5×10	SCREW M5×10	2
74	42112262	感应器安装板	SENSOR PLATE	1
75	421S13019	螺钉M4x6	BOLT	2
76	42124025	轴承	BEARING	2
77	H03035	轴用弹性挡圈22	RETAINING RING	4
78	42128057	波形垫圈26.4x33.9x3.5	WAVED WASHER 26.4X33.9X3.5	2
79	42129014	止推轴环	THRUST COLLAR	2
80	42101138	滑动支架	ELEVATING BRACKET B	1
81	421S13081	内六角圆柱头螺钉	HEXAGONAL HOLE BOLT	1
82	42101139	角刀架支座	KNIFE HOLDER BASE	2
83	421S13050	螺钉M4x8	SCREW M4X8	2
84	400831	左刀架	KNIFE HOLDER A	2
85	400832	右刀架	KNIFE HOLDER B	2
86	421S13049	螺钉M3X12	SCREW M3X12	4
87	42101047	压片支架	KNIFE HOLDER	4
88	421S30021	轴位螺钉	ECCENTRIC PIN	4
89	42101041	冲头	KNIFE GUIDE	2
90	421S13048	螺钉M3X8	SCREW M3X0.5X8	2
91	42128034	垫圈 M3	WASHER M3	4
92	W02025	弹簧垫圈M3	SPRING WASHER M3	4
93	42128034	垫圈 M3	WASHER M3	2
94	42136007	弯管接头	HOSE ELBOW	2
95	N01004	螺母M5	NUT M5	2
96	42119011	左角刀	CORNER KNIFE L	2
97	42119010	右角刀	CORNER KNIFE R	2

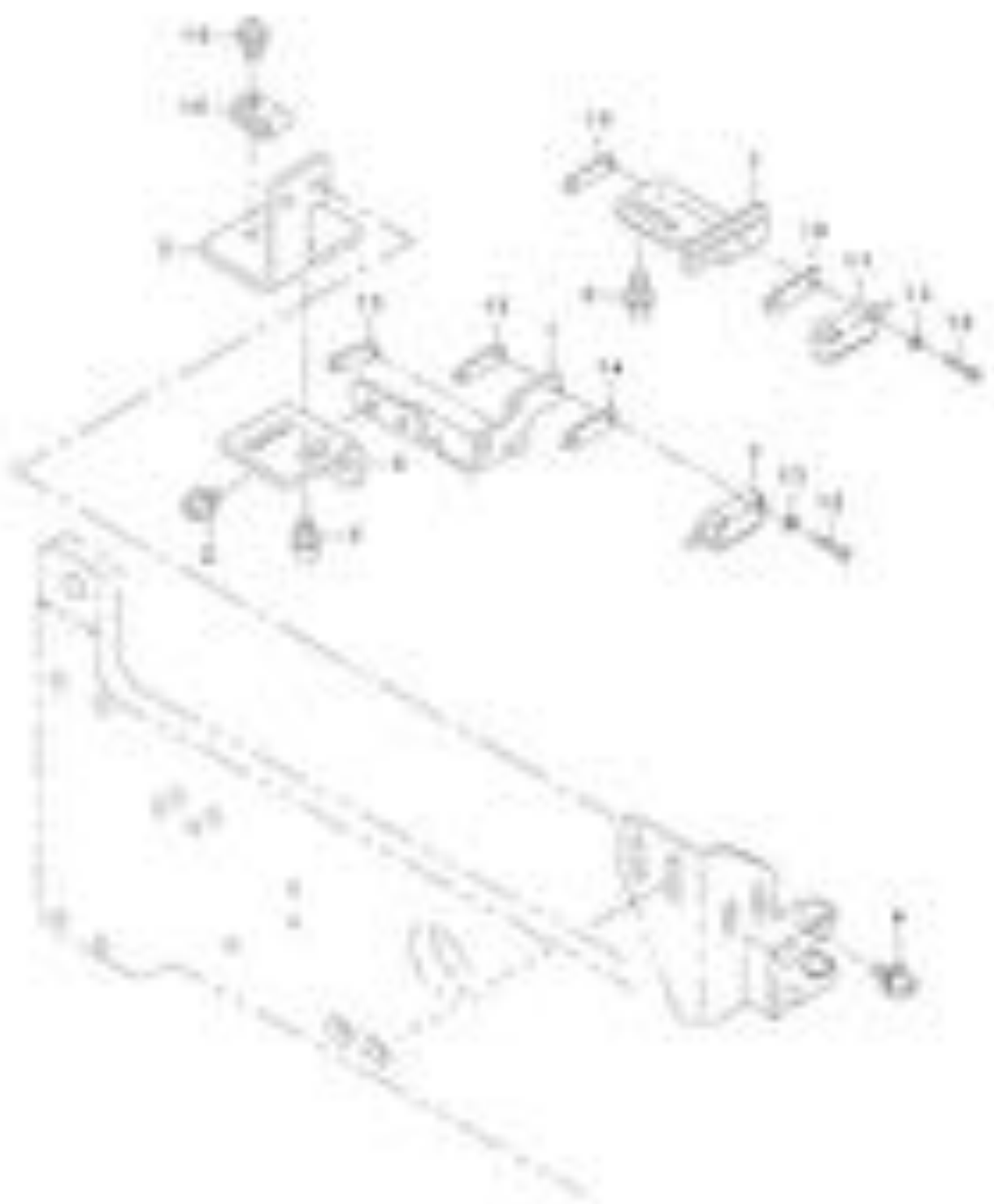



## 24、袋盖传感器部件/FLAP PHOTOTUBE COMPONENTS

序号 Ref.No.	公司件号 Part No.	名称	Description	数量 Amt.
1	42112076	袋盖传感器支架	SLANT FLAP SENSOR BRACKET	1
2	421S13003	螺钉M4X8	SCREW M4X8	2
3	42112077	左传感器支架	FLAP SENSOR BRACKET L	1
4	421S13012	螺钉M4x10	SCREW M4x10	2
5	42112078	传感器固定架	SLANT FLAP SENSOR BRACKET	1
6	421S13003	螺钉M4X8	SCREW M4X8	2
7	42112079	右传感器支架	FLAP SENSOR BRACKET R	1
8	421S13012	螺钉M4x10	SCREW M4x10	2
9	42130025	袋盖传感器	FLAP SENSOR N ASM	1
10	421S11008	十字带垫螺钉M4X10	SCREW M4X10	1
11	42130025	袋盖传感器	FLAP SENSOR N ASM	1
12	421S10011	螺钉M2x12	SCREW M2X12	4
13	42128018	垫圈M2	WASHER M2	4
14	42112022	传感器安装板	FIBER BRACKET SPACER	2
15	42112021	传感器固定板	FIBER BRACKET	2
16	41711014	线夹	CABLE CLAMP	1

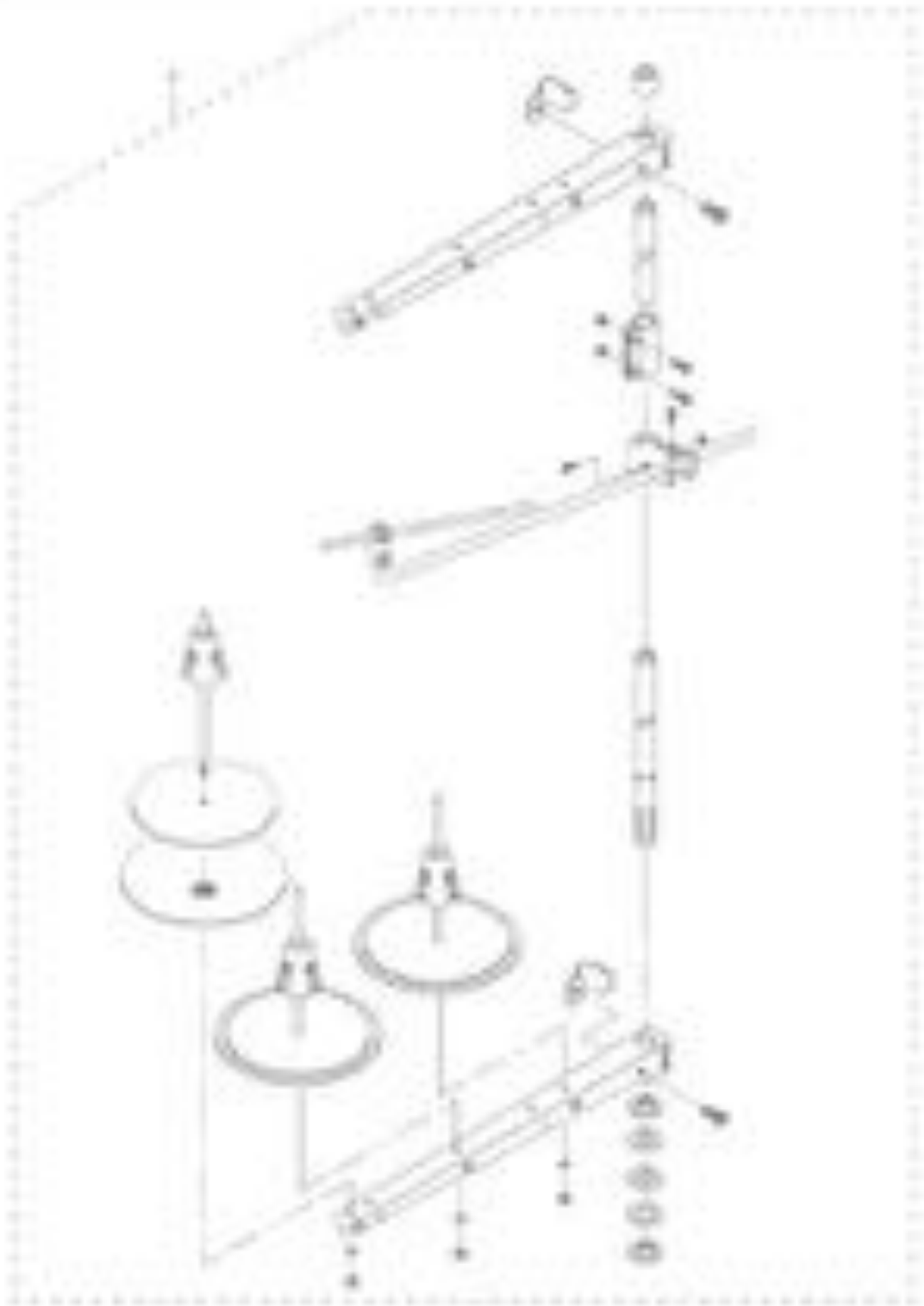

**25、线架组件/THREAD SHAFT COMPONENTS**

序号 Ref.No.	公司件号 Part No.	名 称	Description	数量 Amt.
1	1293100400	线架组件3DRTHF	THREAD SHAFT COMPONENTS	1



26、附件清单/ACCESSORIE PART COMPONENTS

序号 Ref.No.	公司件号 Part No.	名称	Description	数量 Amt.
1	42118002	大梭心	ASSY BOBBIN	2
2	42119008	中刀	KNIFE RIGHT	1
3	900777	缝纫机油	DEFRIX OIL NO.1	1
4	20131038	油壶	OILER ASM.	1
5	20131051	镊子	TWEEZERS	1
6	10131002	大螺丝刀	SCREW DRIVER LARGE	1
7	10131004	小螺丝刀	SCREW DRIVER SMALL	1
8	10131003	中螺丝刀	SCREW DRIVER MIDDLE	1
9	61700004	保险丝8A	FUSE WIRE	2
10	40731002	塑料包装袋	ACCESSORIE BAG	1
11	42130028	反射纸	REFLECTION SHEET	2
12	42122031	服装橡胶压脚	GARMENT CLAMP RUBBER	2
13	42122010	袋盖橡胶	FLAP PRESSER RUBBER	2
14	42137034	T5878-68B/78说明手册	T5878-68B/78 INSTRUCTION MANUAL	1
15	42137035	T5878-68B/78操作说明(中文)	T5878-68B/78 OPERATING INSTRUCTION(CHINESE)	1
16	42137036	T5878-68B/78操作说明(英文)	T5878-68B/78 OPERATING INSTRUCTION(ENGLISH)	1
17	40717002	机针MT190 16#	NEEDLE MT190 16#	10
18	20131044	直柄1.5内六角扳手	STRAIGHT SHANK ALLEN KEY 1.5MM	1
19	4073100600	L形扳手	L-SHAPED WRENCH ASM.	1
20	40731015	十字螺丝刀	RECESSED HEAD DRIVER	1
21	30131005	扳手6X7	WRENCH 6X7	1
22	30131006	扳手8X10	WRENCH (8X9)	1
23	42122019	压脚橡胶(海绵)	GARMENT CLAMP RUBBER(SPONGE)	4
24	42130034	反光纸	REFLECTION SHEET B	1
25	42119010	角刀8-10-12(右)	CORNER KNIFE 8-10-12 R	1
26	42119011	角刀8-10-12(左)	CORNER KNIFE8-10-12 L	1
27	42119013	角刀14-16(右)	CORNER KNIFE 14-16 R	1
28	42119014	角刀14-16(左)	CORNER KNIFE 14-16 L	1
29	42119015	角刀18-20(右)	CORNER KNIFE 18-20 R	1
30	42119016	角刀18-20(左)	CORNER KNIFE 18-20 L	1



27、电控箱组件 /TRANSMISSION BOX COMPONENTS

序号 Ref.No.	公司件号 Part No.	名称	Description	数量 Amt.
1	42100051	电控箱68B组件	CTL BOX 68B ASM	1
2	42100027	电控箱78组件	CTL BOX 78 ASM	1
3	42112279	后盖板	REAR COVER	1
4	61807036	铜柱16mm	PILLARS 16mm	12
5	603410	电路板	CIRCUIT BOARD	1
6	61807037	铜柱36mm	PILLARS 36mm	4
7	42133011	驱动板	DRIVE PLATE	1
8	421S11012	螺钉M3X10	SCREW M3X10	24
9	61301014	开关电源	SWITCHING POWER SUPPLY	1
10	421S11011	螺钉M4X8	SCREW M4X8	12
11	40733008	750W驱动器	750V DRIVER	1
12	421S13018	螺钉M8X20	SCREW M8X20	4
13	42112282	吊装板(右)	LIFTING PLATE RIGHT	1
14	42112281	吊装板(左)	LIFTING PLATE LEFT	1
15	421S13018	螺钉M8X20	SCREW M8X20	3
16	301798	控制箱	CONTROL BOX	1
17	42128060	垫圈	WASHER	4
18	61600008	风扇金属网罩	MASK	2
19	421S11013	螺钉M4X35	SCREW M4X35	4
20	W01010	垫圈M8	WASHER M8	4
21	N01008	螺母M8	NUT M8	4
22	61600006	风扇	FAN	1
23	42112277	右侧梭板	SHUTTLE PLATE	1
24	N01001	螺母M4	NUT M4	14
25	61600005	防尘罩	DUST COVER	1
26	42133009	电机驱动器	MOTOR DRIVER	1
27	61910015	插销式扣线套	BOLT TYPE BUCKLE LINE SET	3
28	60900025	电源转接板	POWER SUPPLY ADAPTER PLATE	1
29	42112278	前盖板	FRONT COVER PLATE	1
30	403S11043	螺钉M4X12	SCREW M4X12	4
31	403S11043	螺钉M4X12	SCREW M4X12	4
32	40730004	主电源开关	SWITCH	1
33	42137001	接地标识	GROUNDING MARK	1
34	4211229200	变压器支架	VOLTAGE TRANSFORMER BRACKET	1
35	42130111	变压器	VOLTAGE TRANSFORMER	1
36	S05085	螺钉M6X15	SCREW M6X15	1
37	W01003	垫片M6	WASHER M6	8
38	N01012	螺母M6	NUT M6	4
39	42130110	闭环驱动器	CLOSED LOOP DRIVER	1
40	W01001	垫片M4	WASHER M4	2
41	N01001	螺母M4	NUT M4	2
42	S05059	螺钉M4X12	SCREW M4X12	2
43	42133010	LED灯	LED LAMPS	1
44	40712344	穿线灯支架	LED LAMPS BRACKET	1

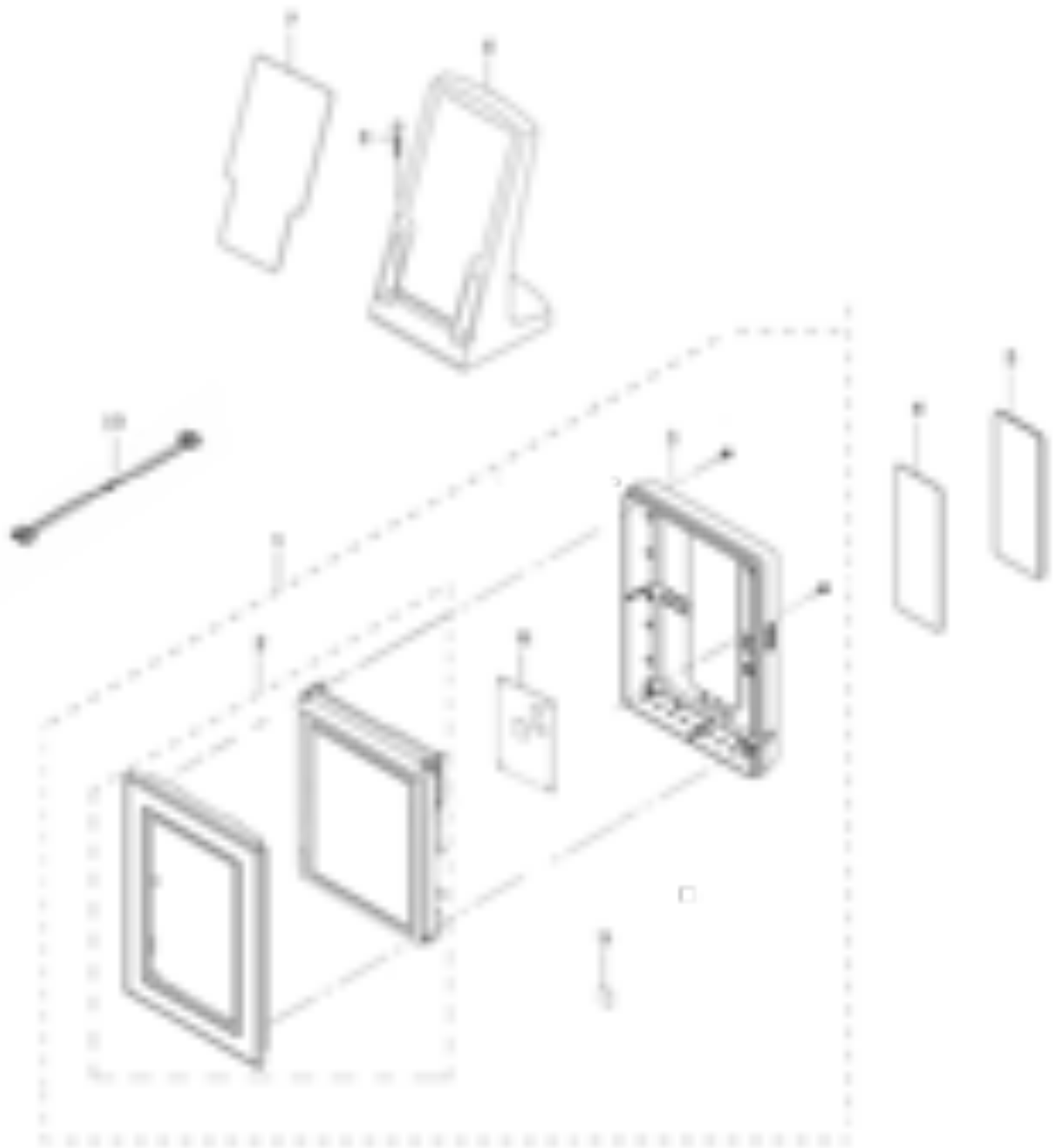



28、操作面板组件 /OPERATION PANEL COMPONENTS

序号 Ref.No.	公司件号 Part No.	名称	Description	数量 Amt.
1	4213008500	操作屏组件	OPERATION SCREEN ASSEMBLY	1
2	42130085	显示屏 (HMI)	FRONT CASE ASSY	1
3	42111006	操作屏后盖	REAR CASE ASSY	1
4	42112287	吸附粘板	ADSORPTION OF STICKY BOARD	1
5	42130101	磁贴	MAGNETIC PLASTER	1
6	42111007	操作屏座	OPERATION BOX FIXED PLATE(B)ASM	1
7	42112249	吸附板	ADSORPTION PLATE	1
8	421S30028	木螺钉D=4.1X32	WOOD SCREW D=4.1X32	2
9	42130106	SD卡	SD CARD	1
10	42130107	显示屏导线	POWER LINE	1
11	42130116	操作屏核心板	CORE BOARD	1

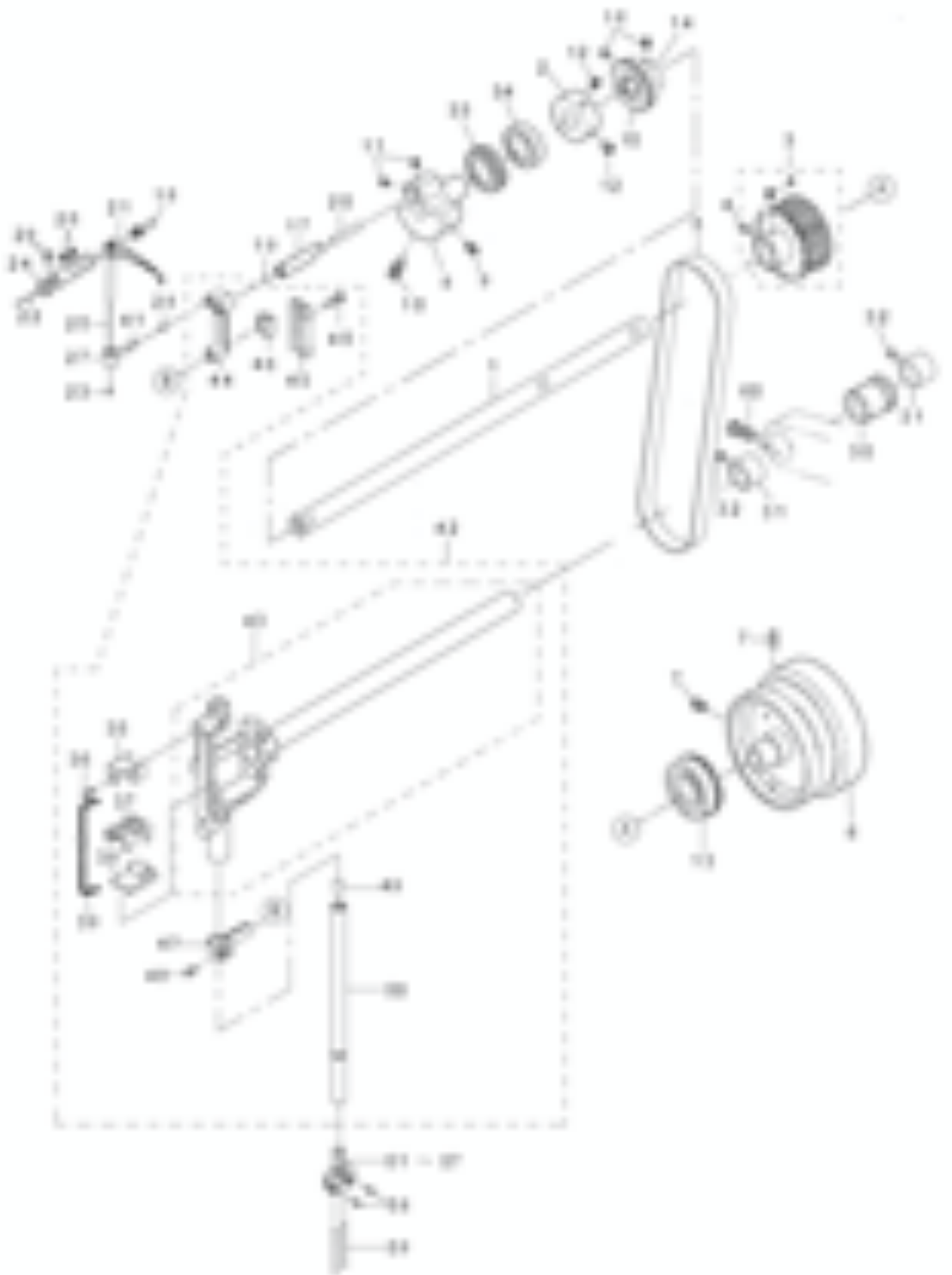

29、主轴和挑线组件(T5878-68B专用)/MAIN SHAFT&THREAD TAKE-UP LEVER COMPONENTS (FOR T5878-68B)

序号 Ref.No.	公司件号 Part No.	名称	Description	数量 Amt.
1	12902001	上轴ST	UPPER SHAFT ST	1
2	12908001	卷线驱动轮	BOBBIN WINDER DRIVING WHEEL	1
3	12935002	同步轮UST组件	TIMING PULLEY ASSY UST	1
4	S10018	螺钉M6X6	SCREW M6X6	2
5	12935003	同步带	TIMING BELT	1
6	302624	手轮	HAND WHEEL	1
7	S10024	螺钉M6X10	SCREW M6X10	2
8	12904006	挑线杆曲柄	THREAD TAKEUP CRANK	1
9	S09017	螺钉M6X10	SCREW M6X10	1
10	129S30005	螺钉M8X6	SCREW M8X6	1
11	S10017	螺钉M6X5	SCREW M6X5	2
12	S10018	螺钉M6X6	SCREW M6X6	2
13	B10009	球轴承6204ZZNR	BALL BEARING 6204ZZNR	1
14	12908002	轴承套座	BALL BEARING BUSH	1
15	B04021	R球轴承60/22ZZ	BALL BEARING RADIAL 60/22ZZ	1
16	S10018	螺钉M6X6	SCREW M6X6	2
17	12926201	针杆曲柄销	CRANKSHAFT NBAR	1
18	12938002	挑线杆支撑接头	THREAD TAKEUP LEVER SUPPORT JOINT	1
19	11626003	油线盖	PUSHER	1
20	12923019	油线	OIL WICK	0.02
21	12938202	挑线杆	TAKE UP LEVER E	1
22	12923019	油线	OIL WICK	0.04
23	12926016	油线盖	RUBBER PLUG	1
24	12938003	挑线架销	THREAD TAKE-UP LEVER PIN	1
25	12923031	油毡	OIL WICK	0.15
26	S10024	螺钉M6X10	SCREW M6X10	2
27	11626004	挑线杆连接柱	TAKE UP LEVER THRUST PIN	1
28	12922015	橡皮塞	PLUG	1
29	12923012	油毡	OIL WICK	2
30	12903002	摆动轴轴套R	BUSH R	1
31	12908003	紧圈	SET SCREW COLLAR	2
32	S10017	螺钉 M6X5	SCREW M6X5	4
33	B10002	球轴承6004ZZNR	BALL BEARING 6004ZZNR	1
34	B04022	球轴承6004ZZ	BALL BEARING 6004ZZ	1
35	12912007	油毡上支架U	FLAT SUPPORT U	1
36	S04030	螺钉M5X6	SCREW M5X6	1
37	12912008	油毡下支架D	FELT SUPPORT D	1
38	12923003	油毡	FLAT	1
39	12923021	油线	OIL WICK	0.02
40	S05048	螺钉M4x10	SCREW M4X10	2
41	12923021	油线	OIL WICK	0.02
42	4210119200	针杆摆动轴组件	NEEDLE BAR ROCKING COMPONENTS	1
43	4210119100	针杆台组件	NEEDLE BAR ROCKING BASE ASM	1
44	12905003	针杆曲柄连杆	NEEDLE BAR CRANK ROD	1
45	12909001	角滑块槽	SLIDE BLOCK SLIDER	1
46	12909002	角滑块	ROCKING ROD SQUARE BLOCK	1
47	12905002	针杆抱箍	NEEDLE BAR CLAMP	1
48	129S30021	螺钉M3.5X8	SCREW M3.5X8	1
49	12923002	针杆塞	CAP NBAR	1

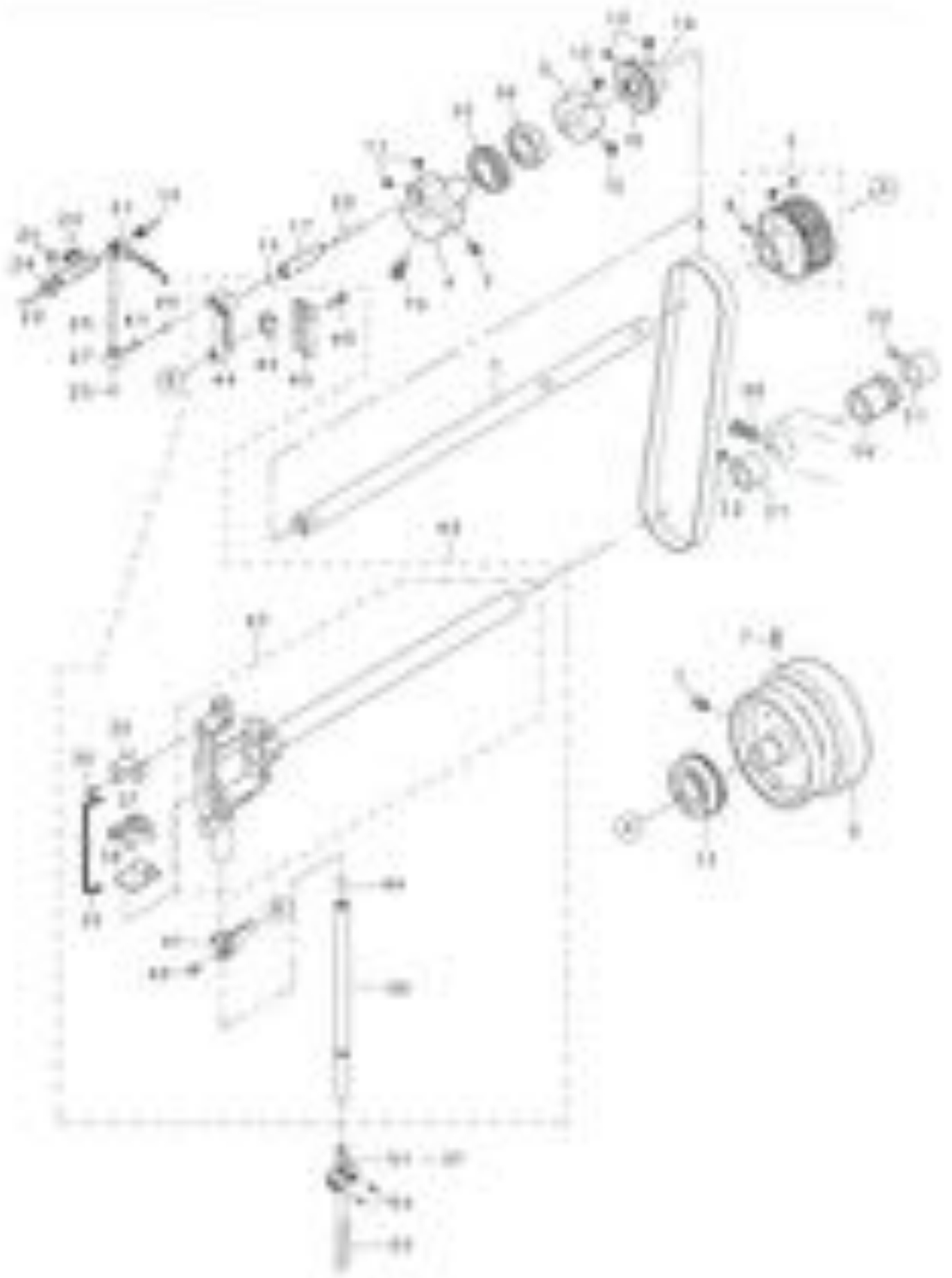

50	42102062	针杆	NEEDLE BAR	1
51	4213401800	针夹头8mm	NEEDLE CLAMP 8MM	1
52	4213401900	针夹头10mm	NEEDLE CLAMP 10MM	1
53	4213402000	针夹头12mm	NEEDLE CLAMP 12MM	1
54	4213402100	针夹头14mm	NEEDLE CLAMP 14MM	1
55	4213401500	针夹头16mm	NEEDLE CLAMP 16MM	1
56	4213401600	针夹头18mm	NEEDLE CLAMP 18MM	1
57	4213401700	针夹头20mm	NEEDLE CLAMP 20MM	1
58	421S10035	螺钉M2.5X3.5	SCREW M2.5X3.5	2
59	40717002	机针MT190 16#	NEEDLE MT190 16#	2
60	S04031	螺钉M6X16	SCREW M6X16	1

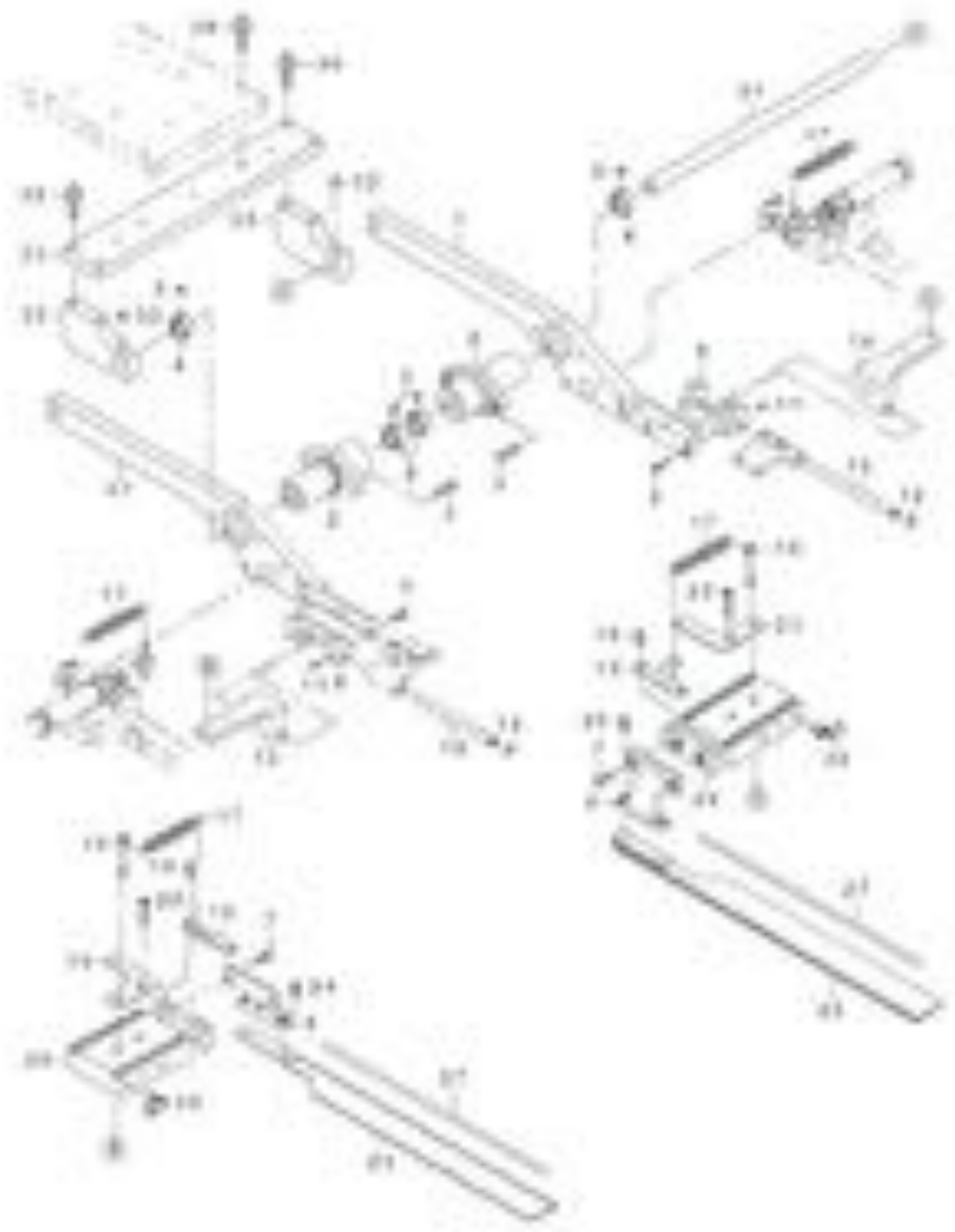

30、压脚组件(1)/ UNIT MECHANISM COMPILATION CLAMP FOOT UNIT(1)

序号 Ref.No.	公司件号 Part No.	名称	Description	数量 Amt.
1	42101013	右夹臂	BASE PRESSER ARM R	1
2	400927	滑动套	FULCLUM BOSS	2
3	S05068	螺钉M5x18	BOLT	4
4	42108003	挡圈	THRUST COLLAR	4
5	S09008	螺钉M5X5	SCREW M5X5	4
6	42101014	折唇支架	FOLDING PLATE BKT	2
7	S05067	螺钉M5x10	BOLT	4
8	400694	袋盖压脚座	TURNING BASE SUPPORT	2
9	S05048	螺钉M4x10	SCREW M4X10	4
10	42102016	袋盖活动轴	TURNING BASE SHAFT	2
11	S09012	螺钉M4X4	SET SCREW M4X4	4
12	H05006	卡簧 5	E-RING	2
13	42101016	左折唇基座	TURNING BASE L	1
14	42101017	右折唇基座	TURNING BASE R	1
15	42112081	折唇板弹簧支架	FOLDING PLATE SPRING BKT	2
16	421S13012	螺钉M4x10	SCREW M4x10	4
17	42127007	拉簧	FOLDING PLATE SPRING	2
18	421S30015	弹簧支柱	SPRING HOLD PIN	2
19	42112082	左弹簧支架	SPRING HOLD PLATE L	1
20	421S17004	螺钉M4X25	SCREW M4X25	1
21	42112083	右弹簧支架	SPRING HOLD PLATE R	1
22	421S17004	螺钉M4X25	SCREW M4X25	1
23	4211208400	右折唇板组件	FOLDING PLATE R	1
24	421S13035	螺钉M4X8	SCREW M4X8	2
25	4211208500	左折唇板组件	FOLDING PLATE L	1
26	421S13035	螺钉M4X8	SCREW M4X8	2
27	42130028	反射纸	REFLECTION SHEET	2
28	42130029	双杆气缸	FOLDING PLATE CYLINDER	1
29	42130029	双杆气缸	FOLDING PLATE CYLINDER	1
30	42136001	弯管接头	ELBOW UNION	2
31	42102017	大压脚支撑轴	PIVOT SHAFT	1
32	421S14009	螺钉M6X6	SCREW M6X6	2
33	400928	大压脚支架	PIVOT BASE	1
34	421S13036	螺钉M6x25	SCREW	2
35	400929	压脚轴支撑架	PIVOT BKT	2
36	421S13036	螺钉M6x25	SCREW	4
37	42101020	左夹臂	BASE PRESSER ARM L	1

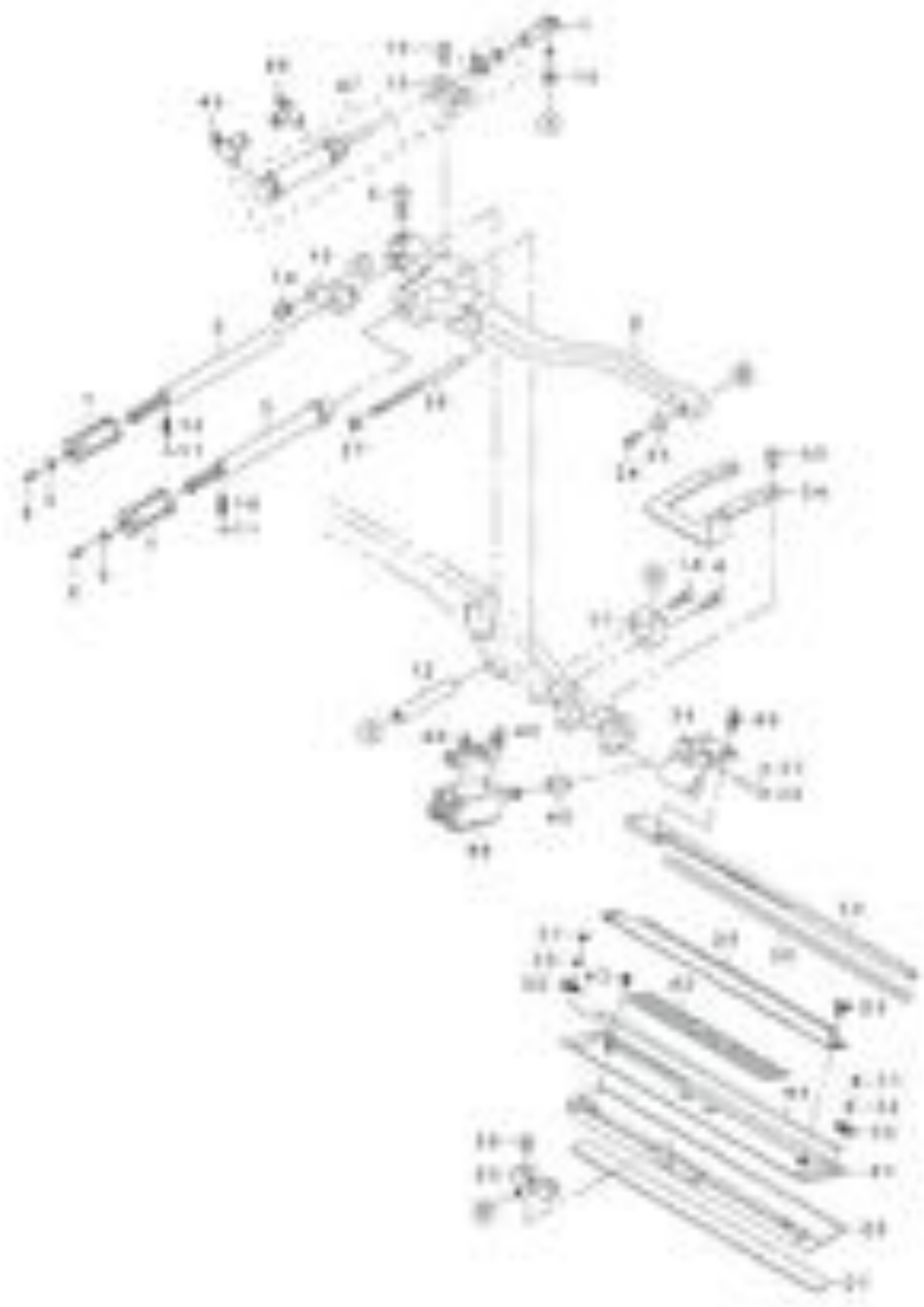



31、压脚组件(2)/CLAMP FOOT UNIT(2)

序号 Ref.No.	公司件号 Part No.	名称	Description	数量 Amt.
1	40736042	鱼眼接头	FEED ADJUSTING JOINT	1
2	400930	左压脚臂	GARMENT CLAMP ARM L	1
3	42102018	左里滑动轴	SLIDING SHAFT L	1
4	S05004	螺钉M5X14	HEXAGONAL-HOLE BOLT M5X14	1
5	42102019	左外滑动轴	SLIDING SHAFT L	1
6	S05111	螺钉M6x20	BOLT	1
7	400750	旋钮	RATCHET KNOB	2
8	421S13038	螺钉M3X6	HEX SCREW M3X 6	2
9	42128004	垫圈	WASHER	2
10	42127008	旋转弹簧	RATCHET SPRING	2
11	42109003	滚珠	BALL	4
12	421S30016	螺栓	STOPPER STAD	2
13	42112086	挡板	STOPPER PLATE	1
14	417S30306	螺钉M5x15	BOLT	2
15	401753	气缸支架	SLIDE CYLINDER BKT	1
16	S05067	螺钉M5x10	BOLT	2
17	42101022	挡块	JYJOINT PIN BKT	1
18	S05004	螺钉M5X14	HEXAGONAL-HOLE BOLT M5X14	1
19	421S30017	拉杆	JOINT PIN	1
20	400931	左压脚板	GARMENT CLAMP L	1
21	42122031	服装橡胶压脚	GARMENT CLAMP RABBER RIGHT	1
22	421S10023	螺钉M5X8	SCREW M5X8	2
23	42101024	压脚支架	CLAMP PIVOT PIN	1
24	421S13035	螺钉M4X8	SCREW M4X8	1
25	42128026	垫圈	WASHER	1
26	421S30018	螺杆	FOLDING PLATE STOPPER	1
27	N01004	螺母M5	NUT M5	1
28	42112088	折唇片压板	FLAP SCALE	1
29	421S30019	旋钮螺钉	KNOB SCREW	2
30	42101025	袋盖挡块	SLANT FLAP STOPPER	2
31	S04036	螺钉M3X4	SCREW M3X4	2
32	42128034	垫圈 M3	WASHER M3	2
33	400932	袋盖连杆	FLAP PRESSER ARM	1
34	42112089	袋盖连杆支架	FLAP-P-CYLINDER-BKT	1
35	S05067	螺钉M5x10	BOLT	2
36	42126009	轴	FLAP PRESSER PIN	1
37	S09042	螺钉M3x4	SCREW M3X4	2
38	42122010	袋盖橡胶	FLAP PRESSER RUBBER	1
39	400933	袋盖压脚	FLAP PRESSER	1
40	421S13012	螺钉M4x10	SCREW	2
41	42112090	左袋盖板	SLANT FLAP BASE L	1
42	42122011	斜袋反光纸	SLANT FLAP SCALE SEAL	1
43	421S17002	螺钉M4X8	SCREW M4X8	2
44	42130031	气缸	AIR CYLINDER	1
45	42101028	连接套	FLAP PRESSER JYJOINT	1
46	42130032	节流阀	SPEED CONTROLLER	2
47	42130033	气缸	AIR CYLINDER	1
48	42130032	节流阀	SPEED CONTROLLER	2
49	42130034	反光纸	REFLECTION SHEET	1

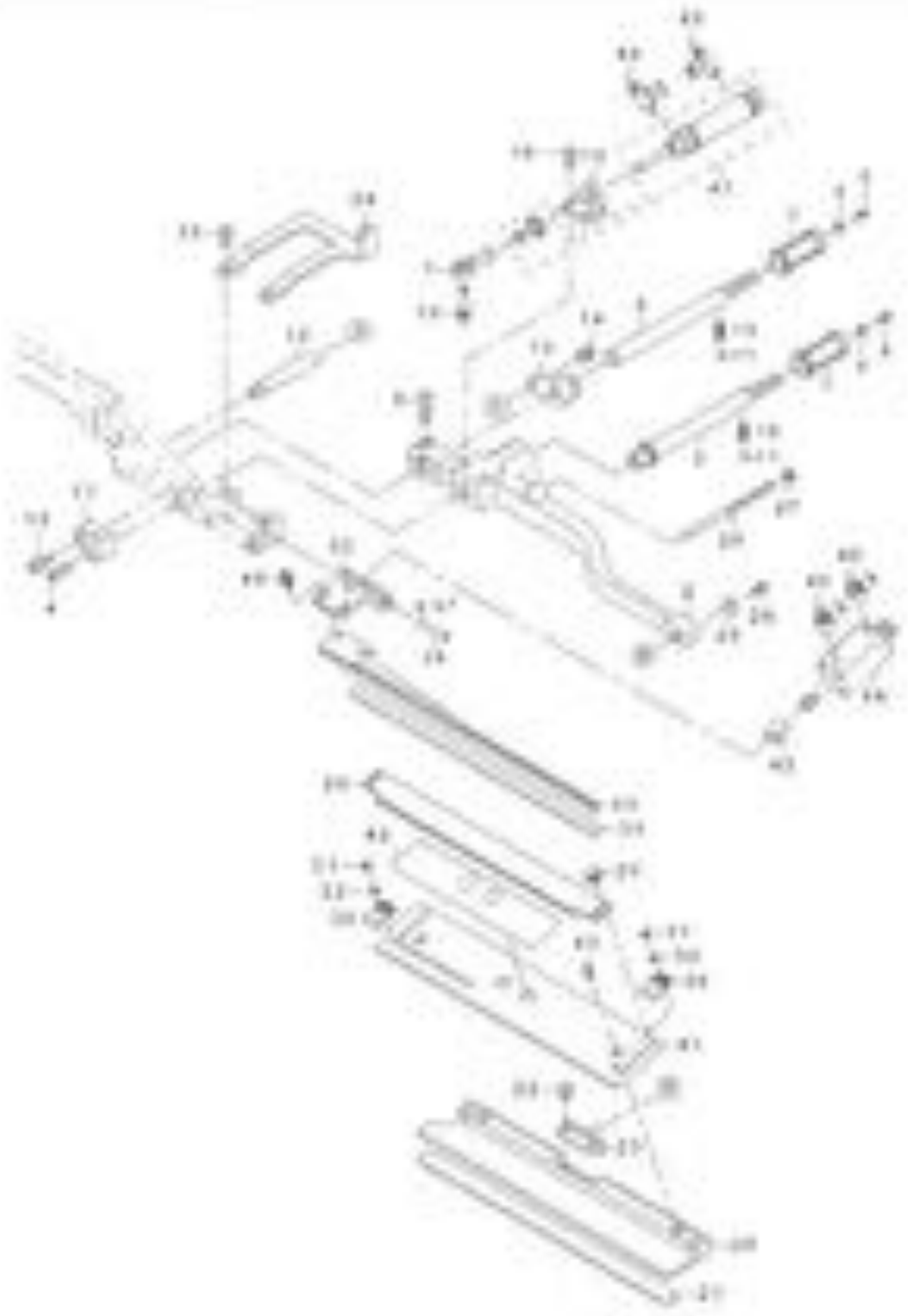

### 32、压脚组件(3)/CLAMP FOOT UNIT(3)

序号 Ref.No.	公司件号 Part No.	名称	Description	数量 Amt.
1	40736042	鱼眼接头	FEED ADJUSTING JOINT	1
2	400934	右压脚臂	GARMENT CLAMP ARM R	1
3	42102018	左里滑动轴	SLIDING SHAFT L	1
4	S05004	螺钉M5X14	HEXAGONAL-HOLE BOLT M5X14	1
5	42102019	左外滑动轴	SLIDING SHAFT L	1
6	S05111	螺钉M6x20	BOLT	1
7	400750	旋钮	RATCHET KNOB	2
8	421S13038	螺钉M3X6	HEX SCREW M3X 6	2
9	42128004	垫圈	WASHER	2
10	42127008	旋转弹簧	RATCHET SPRING	2
11	42109003	滚珠	BALL	4
12	421S30016	螺栓	STOPPER STAD	2
13	42112086	挡板	STOPPER PLATE	1
14	417S30306	螺钉M5x15	BOLT	2
15	401753	气缸支架	SLIDE CYLINDER BKT	1
16	S05067	螺钉M5x10	BOLT	2
17	42101030	挡块	JYJOINT PIN BKT R	1
18	S05004	螺钉M5X14	HEXAGONAL-HOLE BOLT M5X14	1
19	421S30017	拉杆	JOINT PIN	1
20	400935	右压脚板	GARMENT CLAMP R	1
21	42122031	服装橡胶压脚	GARMENT CLAMP RABBER RIGHT	1
22	421S10023	螺钉M5X8	SCREW M5X8	2
23	42101024	压脚支架	CLAMP PIVOT PIN	1
24	421S13035	螺钉M4X8	SCREW M4X8	1
25	42128026	垫圈	WASHER	1
26	421S30018	螺杆	FOLDING PLATE STOPPER	1
27	N01004	螺母M5	NUT M5	1
28	42112088	折唇片压板	FLAP SCALE	1
29	421S30019	旋钮螺钉	KNOB SCREW	2
30	42101032	袋盖挡块	FLAP STOPPER	2
31	S04036	螺钉M3X4	SCREW M3X4	2
32	42128034	垫圈 M3	WASHER M3	2
33	400932	袋盖连杆	FLAP PRESSER ARM	1
34	42112264	袋盖连杆支架	FLAP P CYLINDER BKT	1
35	S05067	螺钉M5x10	BOLT	2
36	42126009	轴	FLAP PRESSER PIN	1
37	S09042	螺钉M3x4	SCREW M3X4	2
38	42122010	袋盖橡胶	FLAP PRESSER RUBBER	1
39	400936	袋盖压脚	FLAP PRESSER	1
40	421S13012	螺钉M4x10	SCREW	2
41	42112092	右袋盖板	FLAP BASE R	1
42	42122013	斜袋反光纸	FLAP SCALE SEAL	1
43	421S17002	螺钉M4X8	SCREW M4X8	2
44	42130031	气缸	AIR CYLINDER	1
45	42101028	连接套	FLAP PRESSER JYJOINT	1
46	42130032	节流阀	SPEED CONTROLLER	2
47	42130033	气缸	AIR CYLINDER	1
48	42130032	节流阀	SPEED CONTROLLER	2

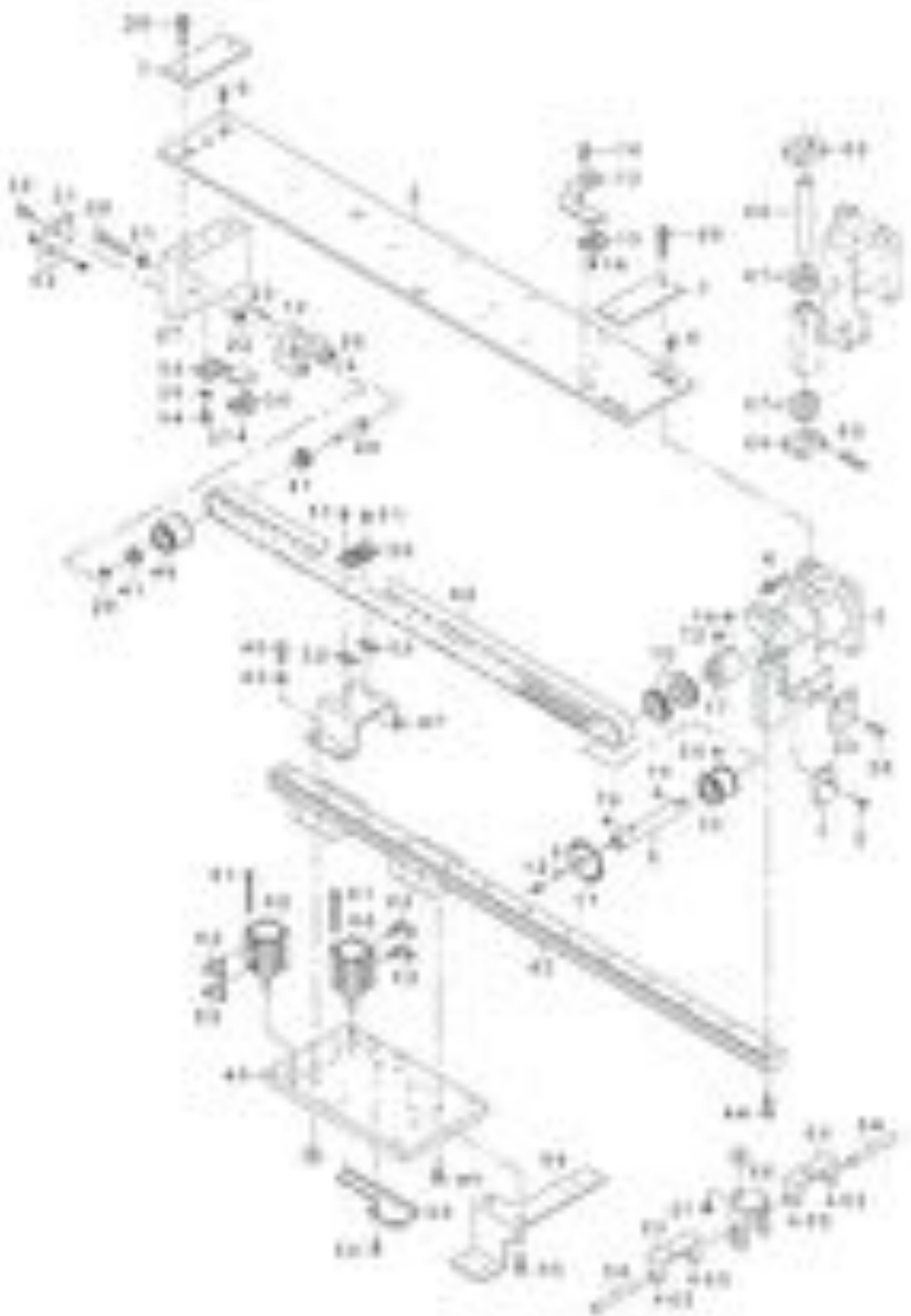

### 33、压脚驱动单元/CLAMP FOOT FEED UNIT

序号 Ref.No.	公司件号 Part No.	名称	Description	数量 Amt.
1	42112093	安全开关安装板	SENSOR PLATE	1
2	S05067	螺钉M5x10	BOLT	2
3	42101034	电机座	CLAMP FOOT BASE	1
4	421S13059	螺钉M5×20	SCREW M6X30	4
5	400937	压脚竖板	CLAMP FOOT PLATE	1
6	421S17005	螺钉M5X16	SCREW M5X16	7
7	42112094	压脚吊板	CLAMP FOOT SPACER	2
8	42102020	传动轴	CLAMP FOOT MAIN SHAFT	1
9	P03015	销2×8.5	SPRING PIN	1
10	B10018	轴承	BALL BEARING	2
11	42112095	光栅盘	CLAMP FEED DETECTIVE PLATE	1
12	421S13028	螺钉M5X14	SCREW M4X8	1
13	42112096	压脚前传感支架	CLAMP FEED SENSOR BKT	1
14	413S13023	螺钉M6x12	BOLT	2
15	40330010	光电传感器	PHOTO SENSOR	1
16	421S10015	螺钉M3X8	SCREW M3X8	1
17	42108005	连轴器	COUPLING	1
18	S09007	螺钉M6X8	SCREW M6X8	2
19	400938	皮带轮支架	FOLLOW PULLEY BKT	1
20	421S13042	螺钉M8x35	SCREW	1
21	W01010	垫圈M8	WASHER M8	1
22	N01011	螺母M8	NUT M8	1
23	P03018	定位销	SPRING PIN	1
24	42102021	后滑轮轴	FOLLOW PULLEY SHAFT	1
25	421S14005	螺钉M4X6	SCREW M4X6	2
26	42128007	垫圈	WASHER	1
27	400939	后壁	CLAMP FOOT BLOCK	1
28	421S13039	螺钉M6X30	SCREW M6X30	4
29	42112097	导轨前挡板	LM STOPPER F	1
30	413S13023	螺钉M6x12	SCREW M6X14	2
31	400940	导轨后挡板	LM STOPPER R	1
32	S05028	螺钉M6x14	SCREW M6X14	2
33	42112099	后传感支架	SENSOR BKT	1
34	413S13023	螺钉M6x12	BOLT	2
36	40330010	光电传感器	PHOTO SENSOR	1
37	421S10015	螺钉M3X8	SCREW M3X8	1
38	4213500100	前同步轮组件	DRIVING PULLEY	1
39	S09007	螺钉M6X8	SCREW M6X6	2
40	4213500200	后同步轮组件	FOLLOW PULLEY	1
41	42124007	轴承	BEARING	2
42	42135003	同步带	TIMING BELT	1
43	42109004	导轨	LM GUIDE	1
44	S05031	螺钉M6X20	SCREW M6X20	2
45	400917	压脚基座	SLIDE BASE	1
46	413S13023	螺钉M6x12	BOLT	4
47	42112100	皮带支架	BELT CLAMP BASE	1
48	413S13023	螺钉M6x12	SCREW M6X16	4
49	42128040	垫圈	WASHER	4
50	42112101	皮带扣	BELT CLAMP	1
51	S05067	螺钉M5x10	BOLT	4

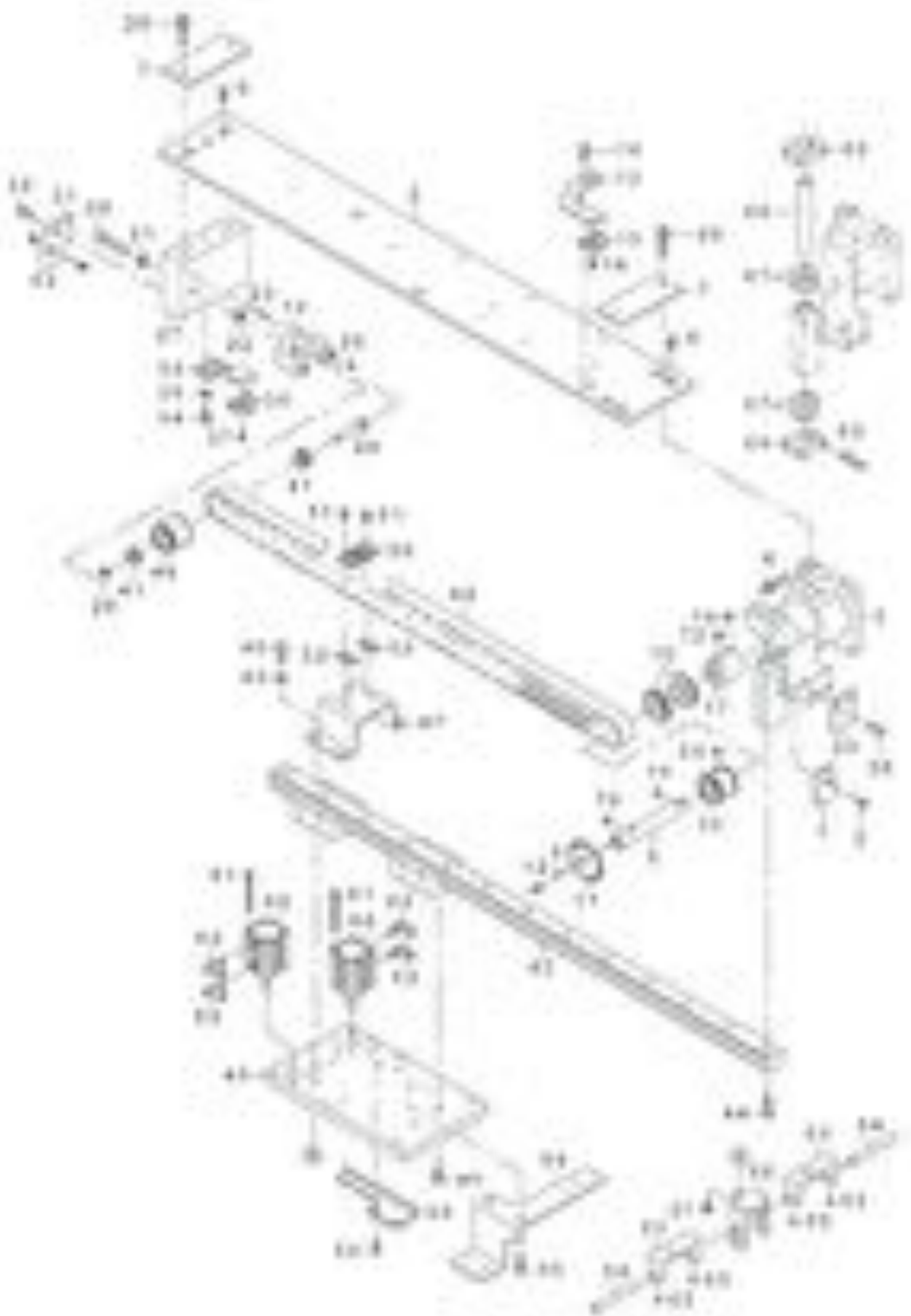

52	42112102	皮带扣压板	BELT CLAMP SPACER	2
53	400941	压脚驱动支架	LIFTING BLOCK	2
54	42102022	吊轴	LIFTING SHAFT	2
55	421S14005	螺钉M4X6	SCREW M4X6	4
56	42112103	吊杆导向	LIFTING GUIDE	1
57	S05067	螺钉M5x10	BOLT	2
58	42112104	传感器板	SENSOR PLATE	1
59	S05067	螺钉M5x10	BOLT	2
60	42130035	气缸	AIR CYLINDER	2
61	421S13046	螺钉M5X45	SCREW M5X45	8
62	42130032	节流阀	SPEED CONTROLLER	4
63	421S30020	限位螺栓	STOPPER BOLT	1
64	42112105	拖链支架	PAVING PLATE BASE	1
65	413S13023	螺钉M6x12	SCREW M6X14	2
66	42102023	中压板转轴	PIVOT SHAFT	1
67	42128010	垫圈	THRUST WASHER	4
68	400918	中压板挡块	BINDER PIVOT BASE A	2
69	S05083	螺钉M5X30	HEXAGONAL-HOLE BOLT	2
70	S09007	螺钉M6X8	SCREW M6X8	2

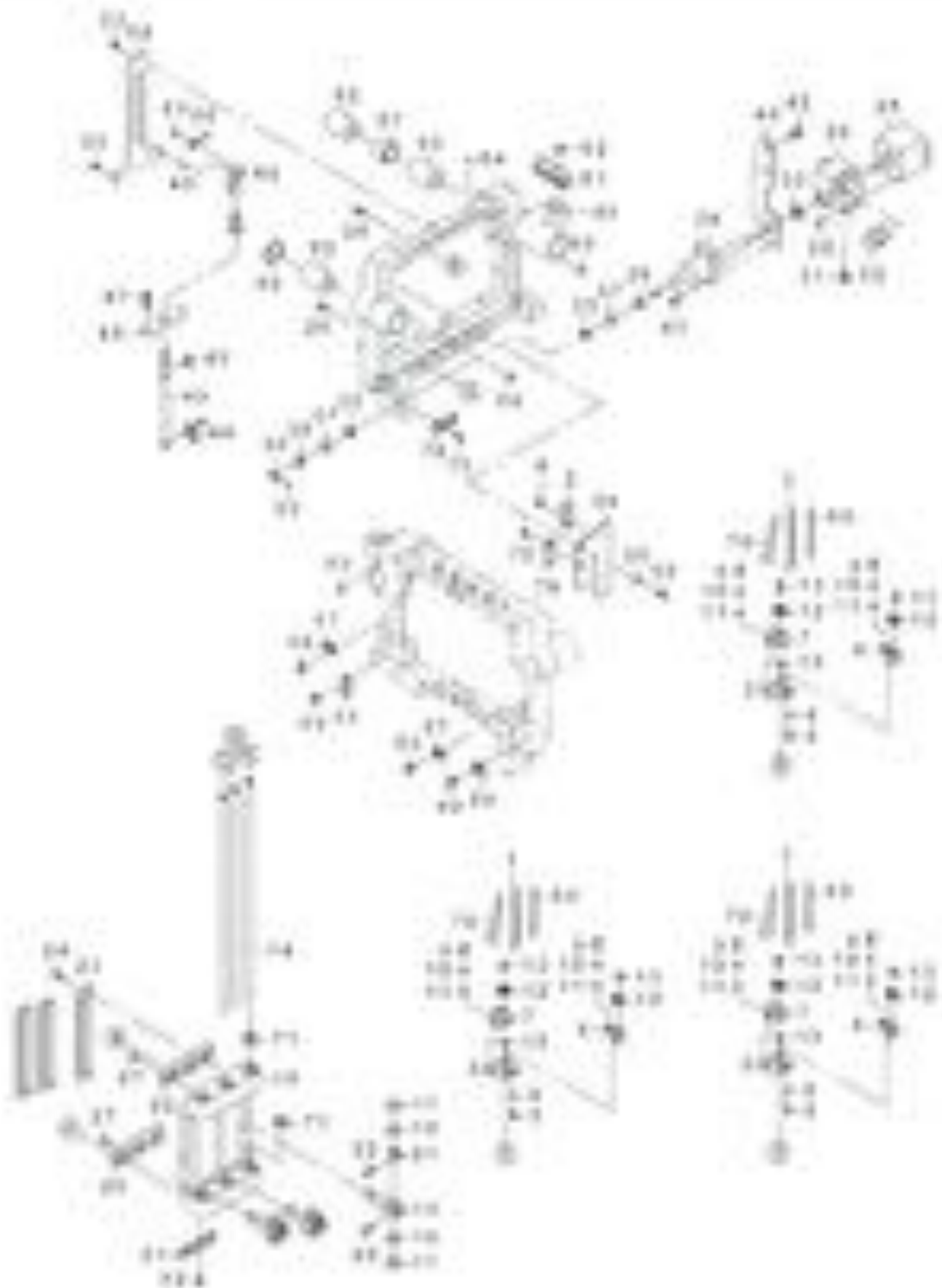



### 34、角刀组件(1)/CORNER KNIFE UNIT(1)

序号 Ref.No.	公司件号 Part No.	名称	Description	数量 Amt.
1	42101041	冲头	KNIFE GUIDE	3
2	42130040	传感器	AIRCYLINDER SENSOR	1
3	42101043	角刀架支座	KNIFE HOLDER BASE	3
4	421S10015	螺钉M3X8	SCREW M3X 8	1
5	421S13048	螺钉M3X8	SCREW M3X8	3
6	42128019	垫圈 M3	WASHER M3	3
7	400832	右刀架	KNIFE HOLDER R	3
8	400831	左刀架	KNIFE HOLDER L	3
9	421S13049	螺钉M3X12	SCREW M3X12	6
10	42128019	垫圈 M3	WASHER M3	6
11	W02025	弹簧垫圈M3	SPRING WASHER M3	6
12	400730	压片支架	KNIFE HOLDER	6
13	421S30021	轴位螺钉	ECCENTRIC PIN	6
14	42102024	角刀轴	ELEVATING SHAFT	3
15	421S13050	螺钉M4x8	SCREW M4X8	3
16	400942	角刀支架	ASSY INDEX	1
17	42122014	橡胶垫圈	CUSHION	6
18	W01010	垫圈M8	WASHER M8	6
19	42101049	角刀驱动架	LIFTING BRACKET	3
20	S01003	螺钉M4x12	SCREW M4X12	3
21	400731	挡块	STOPPER COLLOR	3
22	421S13049	螺钉M3X12	SCREW M3X12	3
23	42112106	角刀导向支架	INDEX KNIFE GUIDE	3
24	421S13031	螺钉M4x10	SCREW	6
25	42101050	滚叉滚柱导轨副	CROSS ROLLER	1
26	S05048	螺钉M4x10	SCREW M4X10	6
27	S05094	螺钉M3X8	SCREW M3X8	8
28	42133005	步进电机	ROLLER STACKER MOTOR	1
29	42112107	电机支架	BALL SCREW BRACKET	1
30	421S13038	螺钉M3X6	HEX SCREW M3X 6	4
31	421S13027	螺钉M5x12	BOLT	2
32	42130036	联轴器	COUPLING	1
33	42124008	轴承	BEARING	1
34	42102025	滚珠螺杆	BALL SCREW	1
35	42124009	轴承	BEARING	2
36	42124010	推力轴承	THRUST BEARING	2
37	42129006	止推环	THRUST RING	2
38	42108006	挡圈	AT SOL COLLAR	1
39	S09042	螺钉M3x4	SCREW M3X4	2
40	42112108	滚珠丝杆固定板	BALL SCREW DRIVE PLATE	1
41	S05059	螺钉M4x12	SCREW M4X12	4
42	421S13027	螺钉M5x12	BOLT	2
43	42130037	气缸	AIR CYLINDER	1
44	42130038	节流阀	SPEED CONTROLLER	1
45	42136007	弯管接头	HOSE ELBOW	1
46	42112109	角刀气缸安装架	KNIFE DRIVE CYLINDER BRACKET	1
47	421S13052	螺钉M4X18	SCREW M4X18	2
48	400693	驱动角刀卡槽	CYLINDER NUT	1
49	42126012	角刀驱动导轴	PARALLEL PIN TYPE	1

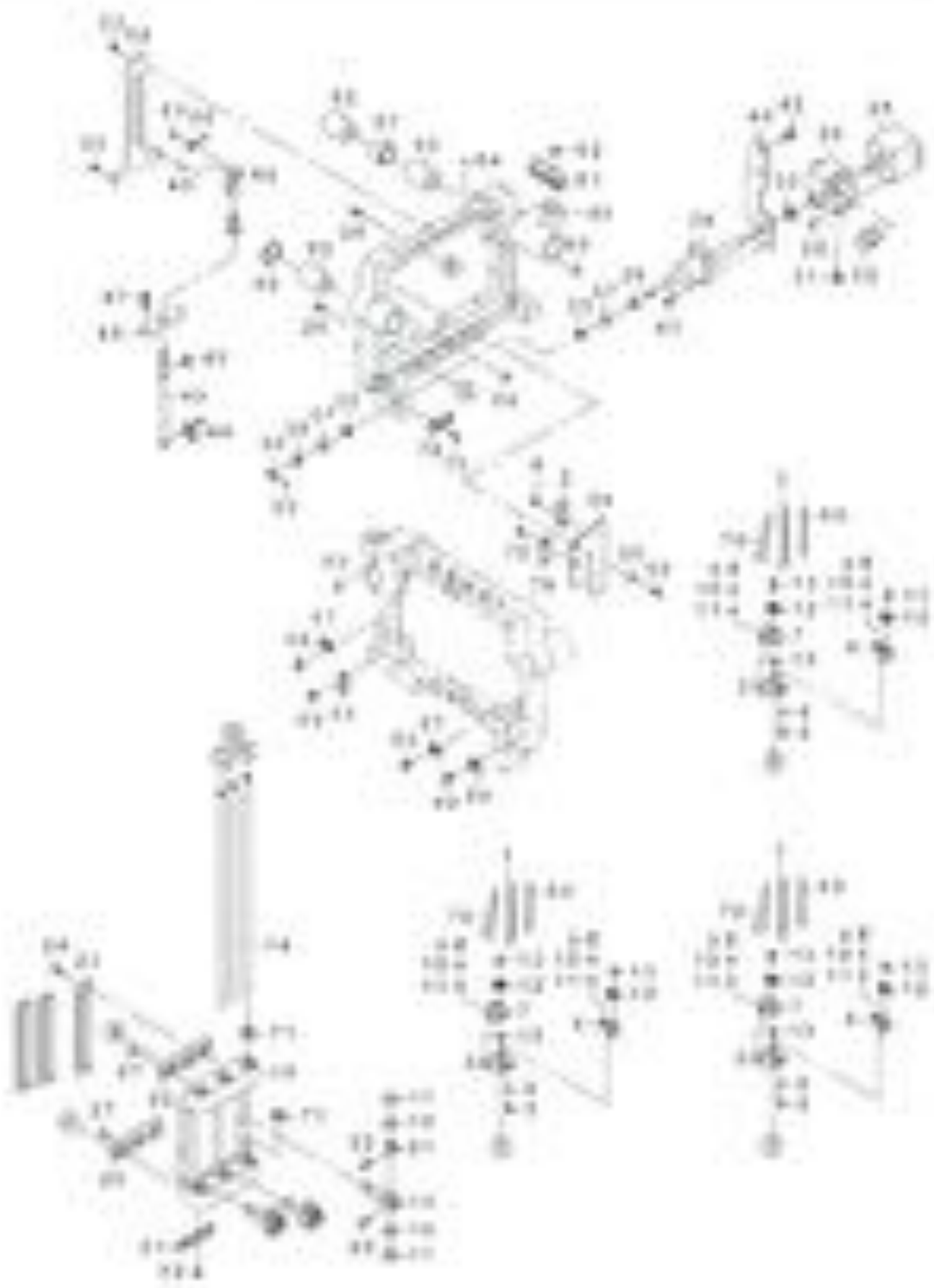

50	42112110	传感器感应板	SENSOR SLIT	1
51	S04037	螺钉M3X6	SCREW M3X6	2
52	42112111	角刀驱动导轴架	NUT GUIDE PLATE	1
53	421S10014	螺钉M4X6	SCREW M4X6	3
54	42112112	传感器支架	SENSOR BRACKET	1
55	421S13031	螺钉M4x10	SCREW	2
56	42128042	垫圈4.3x9x0.8	WASHER 4.3X9X0.8	2
57	61910019	线夹	CABLE CLAMP	2
58	61910020	线夹	CABLE CLAMP	1
59	61910021	线夹	CABLE CLAMP	1
60	421S11008	螺钉M4X10	SCREW M4X10	4
61	42112113	左右传感器板	SENSOR PLATE	2
62	421S13053	螺钉M3x6	BOLT	4
63	400943	角刀滑动支架	INDEX BASE	1
64	S09042	螺钉M3x4	SCREW M3X4	4
65	42124011	轴承	BEARING	3
66	42129007	卡簧	C-RING	1
67	400185	挡套	METAL	1
68	421S10022	螺钉M4X6	SCREW M4X6	6
69	42119010	右角刀	CORNER KNIFE R	3
70	42119011	左角刀	CORNER KNIFE L	3
71	42122015	油封	DUST SEAL	6
72	42130040	传感器	AIRCYLINDER SENSOR	1
73	421S10015	螺钉M3X8	SCREW M3X 8	1
74	42130040	传感器	AIRCYLINDER SENSOR	1
75	421S10015	螺钉M3X8	SCREW M3X 8	1

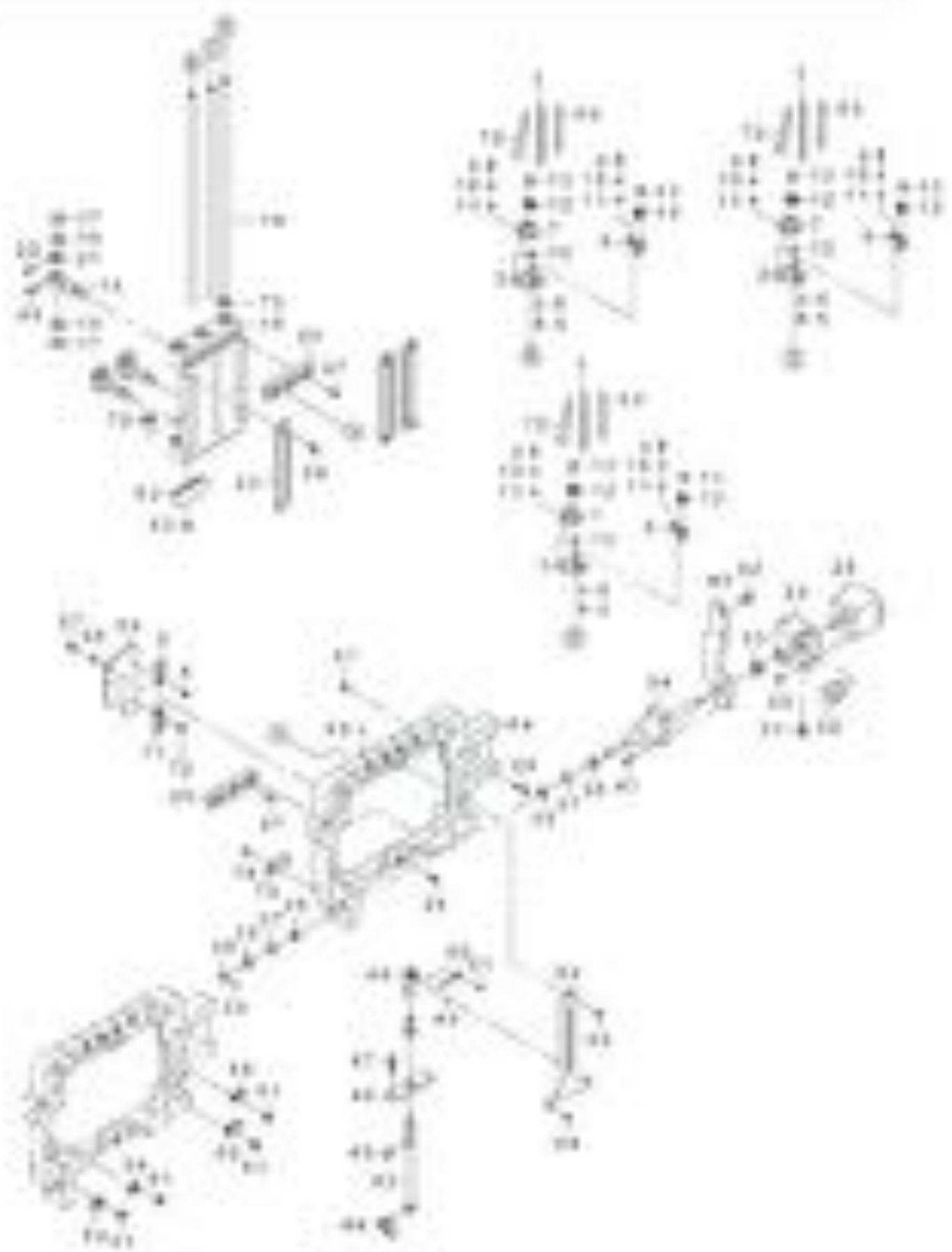

35、角刀组件(2) / CORNER KNIFE UNIT(2)

序号 Ref.No.	公司件号 Part No.	名称	Description	数量 Amt.
1	42101041	冲头	KNIFE GUIDE	3
2	42130040	传感器	AIRCYLINDER SENSOR	1
3	42101043	角刀架支座	KNIFE HOLDER BASE	2
4	421S10015	螺钉M3X8	SCREW M3X 8	1
5	421S13048	螺钉M3X8	SCREW M3X8	3
6	42128019	垫圈 M3	WASHER M3	3
7	42101045	右刀架	KNIFE HOLDER R	3
8	42101046	左刀架	KNIFE HOLDER L	3
9	421S13049	螺钉M3X12	SCREW M3X12	6
10	42128019	垫圈 M3	WASHER M3	6
11	W02025	弹簧垫圈M3	SPRING WASHER M3	6
12	400730	压片支架	KNIFE HOLDER	6
13	421S30021	轴位螺钉	ECCENTRIC PIN	6
14	42102024	角刀轴	ELEVATING SHAFT	3
15	421S13050	螺钉M4x8	SCREW M4X8	3
16	400942	角刀支架	ASSY INDEX	1
17	42122014	橡胶垫圈	CUSHION	6
18	W01010	垫圈M8	WASHER M8	6
19	42101049	角刀驱动架	LIFTING BRACKET	3
20	S01003	螺钉M4x12	SCREW M4X12	3
21	400731	挡块	STOPPER COLLOR	3
22	421S13049	螺钉M3X12	SCREW M3X0.5X12	3
23	42112106	角刀导向支架	INDEX KNIFE GUIDE	3
24	421S13031	螺钉M4x10	SCREW	6
25	42101050	导向架安装架	CROSS ROLLER	1
26	S05048	螺钉M4x10	SCREW M4X10	6
27	S05094	螺钉M3X8	SCREW M3X8	8
28	42133005	步进电机	ROLLER STACKER MOTOR	1
29	42112107	电机支架	BALL SCREW BRACKET	1
30	421S13038	螺钉M3X6	HEX SCREW M3X 6	4
31	421S13027	螺钉M5x12	BOLT	2
32	42130036	联轴器	COUPLING	1
33	42124008	轴承	BEARING	1
34	42102025	滚珠螺杆	BALL SCREW	1
35	42124009	轴承	BEARING	2
36	42124010	推力轴承	THRUST BEARING	2
37	42129006	止推环	THRUST RING	2
38	42108006	挡圈	AT SOL COLLAR	1
39	S09042	螺钉M3x4	SCREW M3X4	2
40	42112288	滚珠丝杆固定板(右)	BALL SCREW DRIVE PLATE (RIGHT)	1
41	S05059	螺钉M4x12	SCREW M4X12	4
42	421S13027	螺钉M5x12	BOLT	2
43	42130037	气缸	AIR CYLINDER	1
44	42130038	节流阀	SPEED CONTROLLER	1
45	42136007	弯管接头	HOSE ELBOW	1
46	42112109	角刀气缸安装架	KNIFE DRIVE CYLINDER BRACKET	1
47	421S13052	螺钉M4X18	SCREW M4X18	2
48	400693	驱动角刀卡槽	CYLINDER NUT	1
49	42126012	角刀驱动导轴	PARALLEL PIN TYPE	1

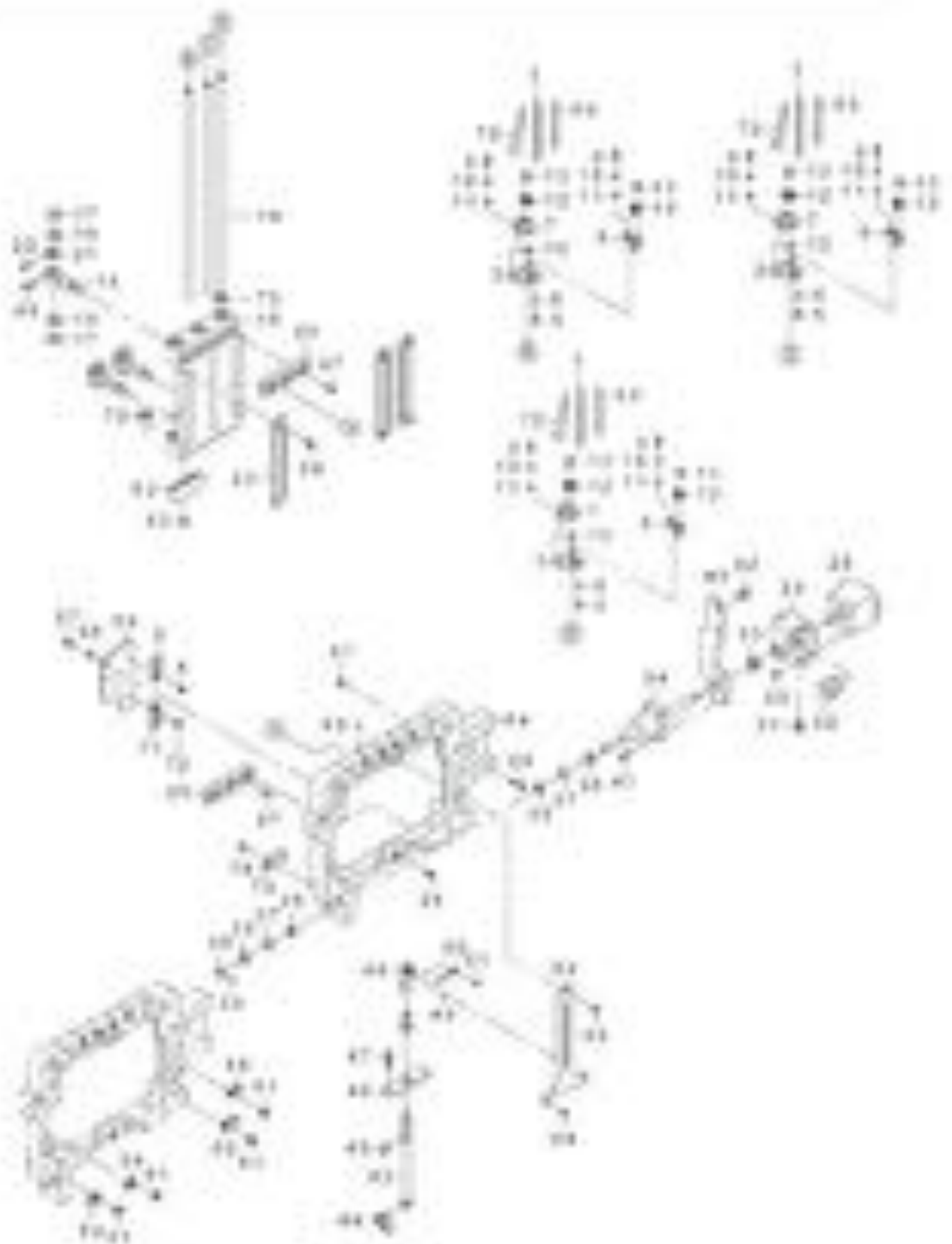

50	42112110	传感器感应板	SENSOR SLIT	1
51	S04037	螺钉M3X6	SCREW M3X6	2
52	42112111	角刀驱动导轴架	NUT GUIDE PLATE	1
53	421S13026	螺钉M4x6	SCREW	1
54	421S10014	螺钉M4X6	SCREW M4X6	2
55	42112112	传感器支架	SENSOR BRACKET	1
56	421S13031	螺钉M4x10	SCREW	2
57	42128042	垫圈4.3x9x0.8	WASHER 4.3X9X0.8	2
58	61910019	线夹	CABLE CLAMP	2
59	61910020	线夹	CABLE CLAMP	1
60	61910021	线夹	CABLE CLAMP	1
61	421S11008	螺钉M4X10	SCREW M4X10	4
62	42112113	左右传感器板	SENSOR PLATE	1
63	421S13053	螺钉M3x6	BOLT	2
64	400944	角刀支架	INDEX BASE FIXED	1
65	S09042	螺钉M3x4	SCREW M3X4	4
66	S05119	螺钉M4x20	BOLT	1
67	N01001	螺母M4	NUT M4	1
68	42119010	右角刀	CORNER KNIFE R	3
69	42119011	左角刀	CORNER KNIFE L	3
70	42122015	油封	DUST SEAL	6
71	42130040	传感器	AIRCYLINDER SENSOR	1
72	421S10015	螺钉M3X8	SCREW M3X 8	1
73	42130040	传感器	AIRCYLINDER SENSOR	1
74	421S10015	螺钉M3X8	SCREW M3X 8	1

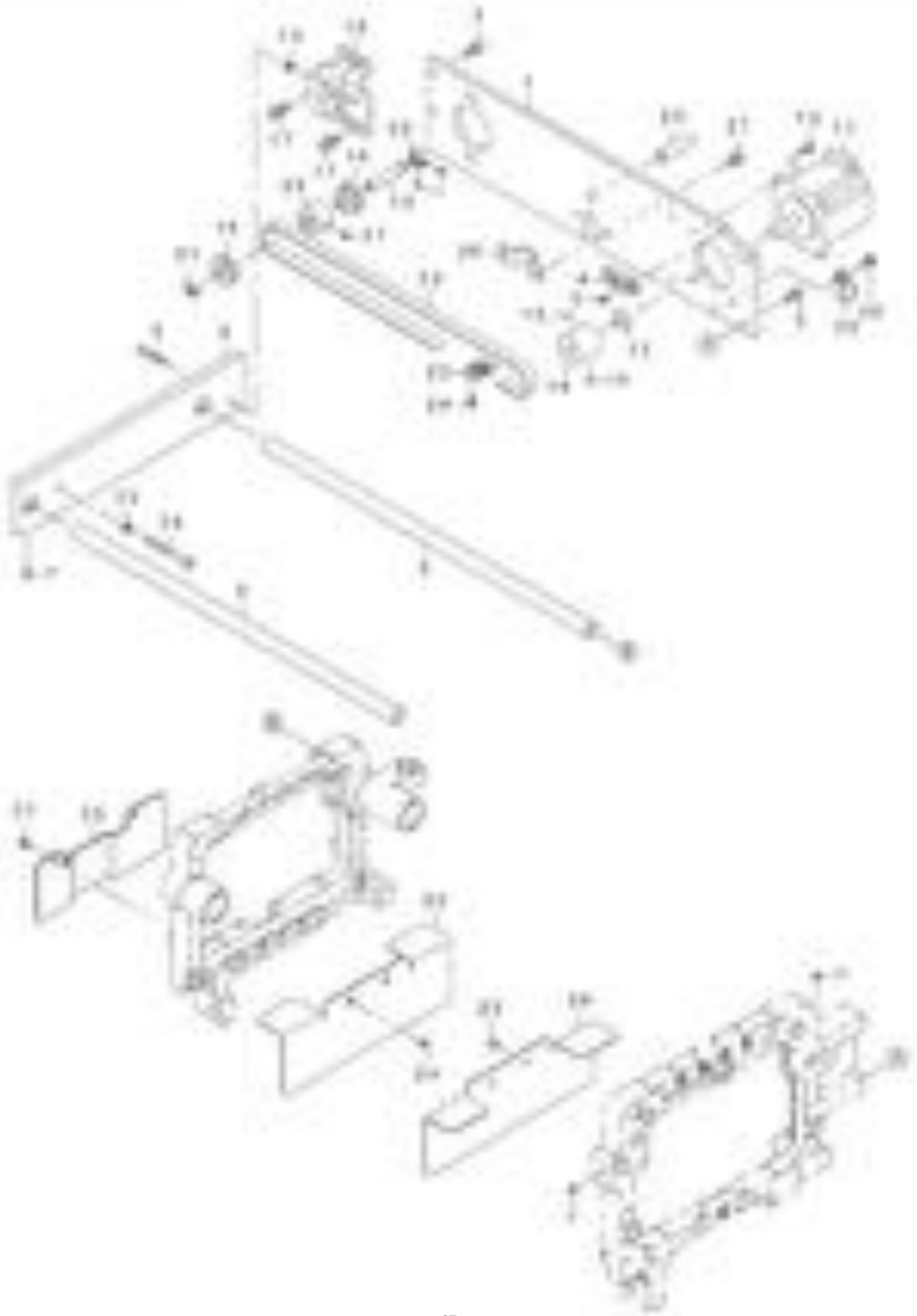



36、角刀组件(3)/CORNER KNIFE UNIT(3)

序号 Ref.No.	公司件号 Part No.	名称	Description	数量 Amt.
1	400945	角刀横板	BASE	1
2	400946	角刀纵板	BASE	1
3	S05087	螺钉M5x12	SCREW M5X12	4
4	42130040	传感器	AIRCYLINDER SENSOR	1
5	421S10015	螺钉M3X8	SCREW M3X 8	1
6	42102026	滑轴	SLIDE SHAFT	2
7	421S14001	螺钉M5x6	SCREW M5X6	3
8	421S14005	螺钉M4X6	SCREW M4X6	8
9	S05134	螺钉M4x25	SCREW M4X25	1
10	N01001	螺母M4	NUT M4	1
11	42133006	角刀电机	CORNER KNIFE MOTOR	1
12	S05048	螺钉M4x10	SCREW M4X10	4
13	42124012	轴承	BEARING	1
14	42135004	前角刀同步轮	DRIVE SPROCKET	1
15	S09010	螺钉M6X5	SCREW M6X5	2
16	42112114	角刀同步轮支架	CORNER KNIFE FEED BRACKET	1
17	421S13027	螺钉M5x12	BOLT	4
18	42124013	轴承	RADIAL BEARING	2
19	42102027	后角刀同步轮轴	LIFTING LEVER SHAFT	1
20	42135005	后角刀同步轮	DRIVEN SPROCKET	1
21	H05009	卡簧7	E-RING 7	1
22	42108007	挡圈	THRUST HOLDER	1
23	42112115	角刀同步带压块	BELT RECEIVER	1
24	421S13019	螺钉M4x6	BOLT	2
25	400947	定位销	PIN	1
26	42112116	固定板	FIXED PLATE	1
27	421S13017	螺钉M5x10	BOLT	2
28	42112117	护板	SLANT CONER COVER	2
29	S02004	螺钉M4x8	SCREW	4
30	42112118	保护板	SLANT CONER COVER	1
31	421S10014	螺钉M4X6	SCREW M4X6	2
32	42135006	同步带	TIMING BELT	1
33	N01004	螺母M5	NUT M5	1
34	421S13046	螺钉M5x45	SCREW M5X45	1
35	61910021	线夹	CABLE CLIP	1
36	421S11008	螺钉M4X10	SCREW M4X10	1
37	421S14005	螺钉M4X6	SCREW M4X6	1

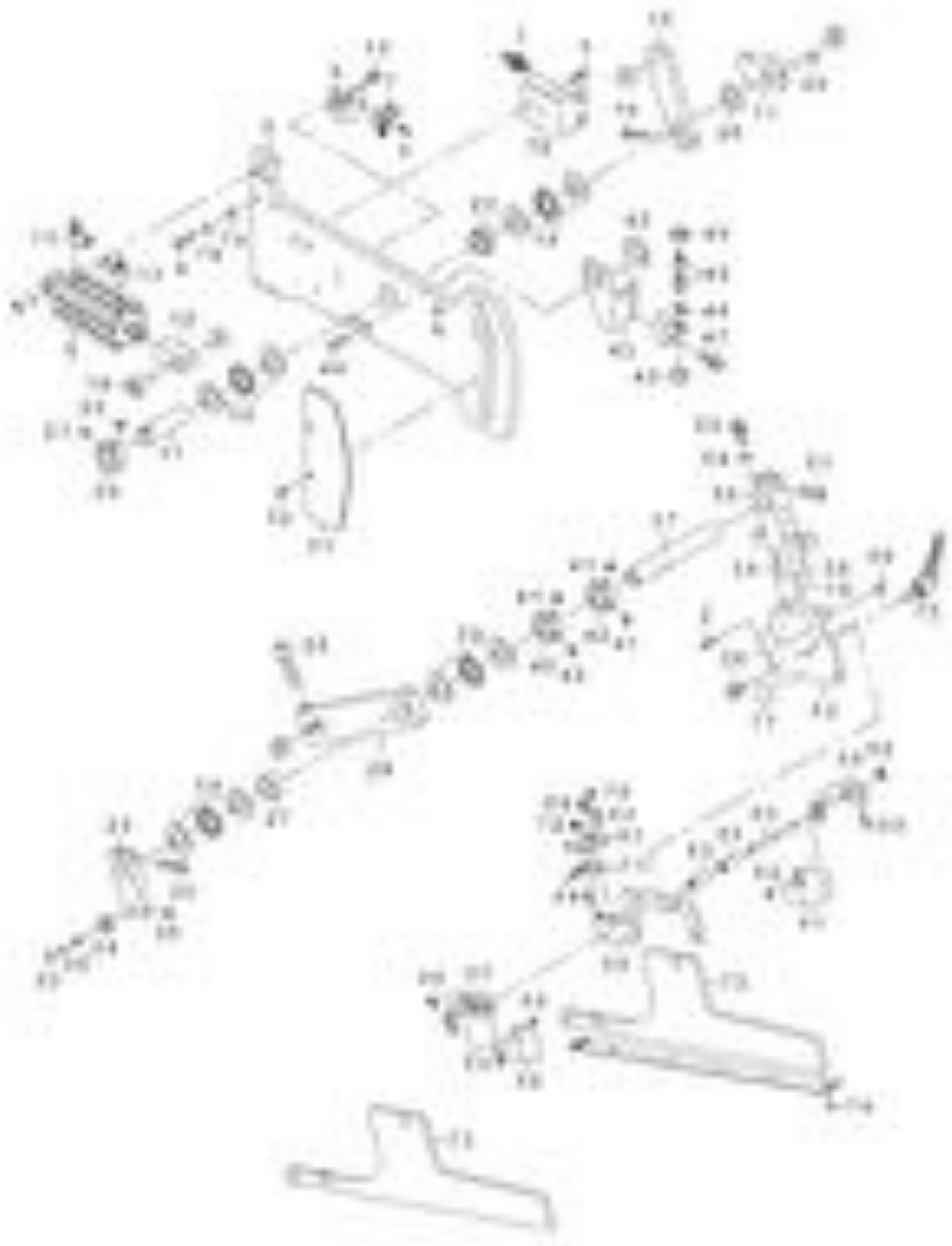

### 37、中压板组件 /BINDER UNIT

序号 Ref.No.	公司件号 Part No.	名称	Description	数量 Amt.
1	42136014	带螺纹气管转接头4	UNION	2
2	421S14018	螺钉M4X15	SCREW M4X15	2
3	S05067	螺钉M5x10	SCREW M5X12	2
4	421S13059	螺钉M5x20	BOLT	4
5	400919	中压板导板	BINDER BASE PLATE	1
6	42130049	气缸	AIR CYLINDER	1
7	40330010	光电传感器	PHOTO SENSOR	1
8	421S11003	螺钉M3X8	SCREW M3X8	1
9	42112119	传感器支架	BINDER SENSOR BKT	1
10	421S13012	螺钉M4x10	SCREW	2
11	42112120	传感器挡板	BINDER SENSOR PLATE	1
12	400948	气缸驱动块	CYLINDER JOINT	1
13	42130050	节流阀	SPEED CONTROLLER	2
14	421S20010	轴位螺钉	SHOULDER SCREW	1
15	400949	中压板连杆	BINDER PLATE	1
16	S05035	螺钉M5X25	HEXAGONAL-HOLE BOLT	1
17	42102028	中压板驱动轴	SHAFT	1
18	42126015	定位轴	PARALLEL PIN	1
19	42124014	薄型轴承1528	UPPER SHAFT THRUST BEARING	2
20	42108008	挡圈	THRUST COLLAR	1
21	421S14009	螺钉M6X6	SCREW M6X6	1
22	S12001	螺钉M6X8	SCREW M6X8	1
23	42103008	铜套	METAL	1
24	400950	连杆B	BINDER PLATE B	1
25	421S13042	螺钉M8X35	SCREW M8X30	1
26	42128043	垫圈15x24x2.5	WASHER 15X24X2.5	1
27	42124015	轴承HMK1510	BEARING	1
28	P03015	定位销φ2x8.5	SPRING PIN	1
29	42101060	连杆C	BINDER PLATE C	1
30	S05035	螺钉M5X25	HEXAGONAL-HOLE BOLT	1
31	42112121	盖板	CAM COVER	1
32	421S13058	螺钉M4X6	SCREW M4X6	2
33	42102029	销	BEARING SHAFT	1
34	B04013	球轴承605ZZ	BALL BEARING	1
35	42103009	导向轮	DRIVING LINK ROLLER.	1
36	S09012	螺钉M4X5	SCREW M4X5	1
37	42102030	中压板上轴	SHAFT	1
38	42126016	定位轴	PARALLEL PIN	2
39	42124014	薄型轴承1528	UPPER SHAFT THRUST BEARING	2
40	42108008	挡圈	THRUST COLLAR	2
41	421S14009	螺钉M6X6	SCREW M6X6	3
42	S12001	螺钉M6X8	SCREW M6X8	1
43	42112122	固定支架	ROCK PLATE	1
44	S05087	螺钉M5x12	SCREW M5X12	2
45	42112123	挡板	ROCK PLATE BKT	1
46	401751	锁头支架	ROCK BASE	1
47	421S13059	螺钉M5X20	BOLT M5x20	2
48	421S30022	球柱塞	BALL PLUNGER	2
49	N01011	螺母M8	NUT M8	2



50	401752	中压板头座	BINDER FITTING BASE	1
51	421S13039	螺钉M6X30	SCREW M6X20	1
52	42112124	中压板调节板	BINDER FITTING BASE	1
53	421S13059	螺钉M5X20	BOLT M5x20	2
54	W01023	垫圈M5	WASHER M5	2
55	42101063	中压板固定支架	BINDER FITTING BASE	1
56	421S13027	螺钉M5x12	BOLT	4
57	42101064	左过布片臂	CLOTH GUIDE ARM L	1
58	42101065	右过布片臂	CLOTH GUIDE ARM R	1
59	421S13060	螺钉M3x12	BOLT	2
60	42112125	左过布片	CLOTH GUIDE L	1
61	42112126	右过布片	CLOTH GUIDE R	1
62	421S10026	螺钉3/32-56X 5.5	SCREW 3/32-56X5.5	4
63	42102031	过布片轴	GUIDE PIN	1
64	421S14017	螺丝M3x12	SCREW	1
65	42103010	过布片铜套	ARM BUSHING	2
66	H05018	卡簧3.5	E-RING 3.5	2
67	42101148	过布片支架	WORKPIECE GUIDE STOPPER	1
68	421S13061	螺钉M3x8	SCREW	1
69	421S14018	螺钉M4X15	SCREW M4X15	4
70	N01001	螺母M4	NUT M4	4
71	42112127	过布片弹簧	WORKPIECE GUIDE SPRING	1
72	421S11003	螺钉M3X8	SCREW M3X8	1
73	4210106700	中压板组件	BINDER BASE	2
74	421S17007	一字沉头螺钉	SCREW	10
75	42131005	扳手	CLAMP LEVER	1
76	42112128	气管支架	CONNECTOR PLATE	1
77	42137021	警告标签25	CAUTION LABEL(25)	1
78	W02001	弹簧垫圈M5	SPRING WASHER M5	4
79	42128015	垫圈	WASHER	4
80	N01001	螺母M4	NUT M4	2

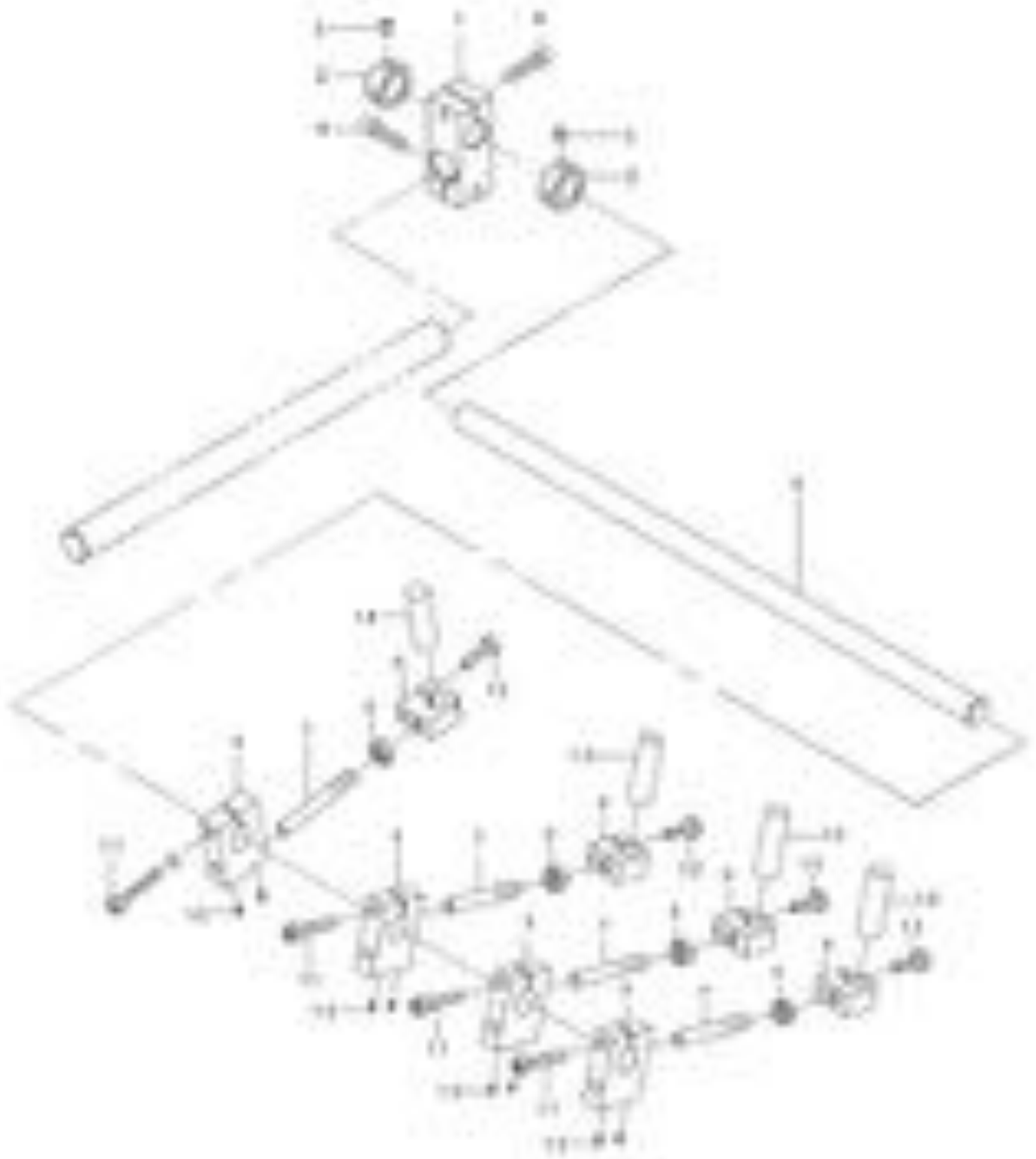

38、定位灯组件/MARKING LIGHT UNIT

序号 Ref.No.	公司件号 Part No.	名 称	Description	数量 Amt.
1	401804	转向支架	STEERING RACK	1
2	42108003	挡圈	THRUST COLLAR	2
3	S09008	螺钉M5X5	SCREW M5X5	4
4	S05068	螺钉	BOLT	4
5	42101127	支架管	SUPPORT TUBE	1
6	40701126	支架	HILDER	4
7	407S30033	测光支架柄	HOLDER	4
8	N01007	螺母M6	NUT M6	4
9	40701041	夹具	CLAMP	4
10	42130104	激光灯	LASER	3
11	421S13072	螺钉M4X25	SCREW M4X25	4
12	S09012	螺钉M4X5	SCREW M4X6	8
13	S05118	螺钉M4X16	SCREW M4X15	4
14	40730020	一字激光灯	LASER	1





39、裤省定位部件 / CLOTH LENGTHEN DEVICE

序号 Ref.No.	公司件号 Part No.	名称	Description	数量 Amt.
1	42130051	气缸	AIR CYLINDER	1
2	42130032	节流阀	SPEED CONTROLLER	2
3	42111003	橡胶头	CLOTH LENGTHEN EDGE	1
4	400952	裤省定位块	CLOTH LENGTHEN SHAFT BASE	1
5	S05040	螺钉M6X16	SCREW M6X16	2
6	42102036	裤省轴	CLOTH LENGTHEN DEVICE SHAFT	1
7	S05072	螺钉M6X30	SCREW M6X30	1
8	400953	裤省转向支架	CLOTH LENGTHEN BRACKET	2
9	S05068	螺钉	BOLT	4
10	42102037	裤省支架轴	CLOTH LENGTHEN BRACKET SHAFT	1
11	H05004	卡簧12	E-RING 12	2
12	42108008	挡圈	THRUST COLLAR	2
13	421S14009	螺钉M6X6	SCREW M6X6	2
14	4211219600	裤省气缸支架组件	CLOTH LENGTHEN BKT ASSY	1
15	42130089	磁开关	MAGNETIC SWITCH	1
16	61911001	气管	URETHANE HOSE BLACK	1
17	42137002	绑扎带	CABLE BAND	6
18	42137021	警告标签25	CAUTION LABEL(25)	1
19	61300007	固定夹	FIXED CLAMP	1

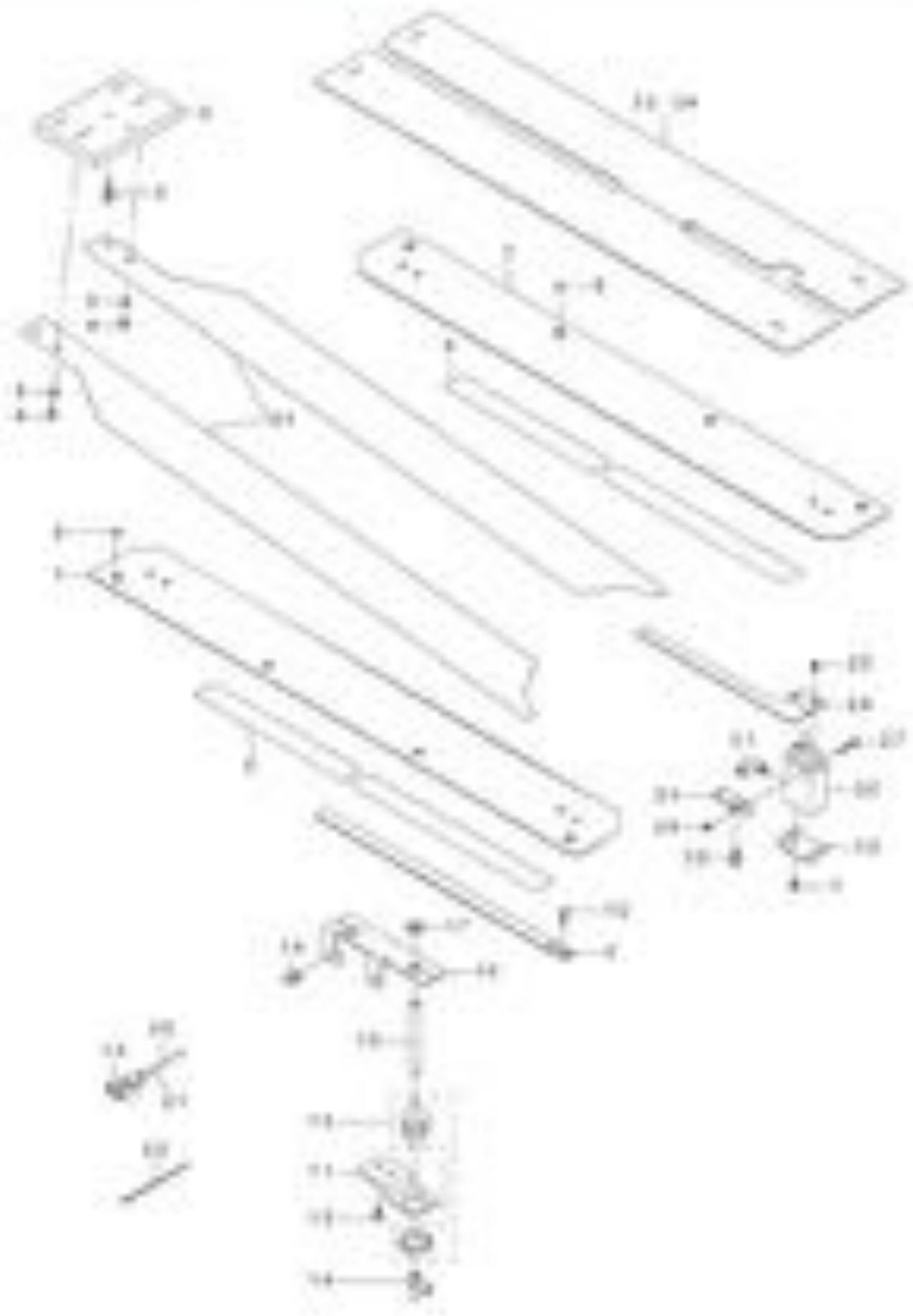

40、三明治送布组件 /PAVING PLATE DEVICE

序号 Ref.No.	公司件号 Part No.	名称	Description	数量 Amt.
1	421S10014	螺钉M4X6	SCREW M4X0.7X6	2
2	400955	底板固定板	PAVING PLATE BKT	1
3	421S13065	螺钉M5x16	BOLT	2
4	421S13019	螺钉M4x6	BOLT	4
5	42128035	垫圈4.3x12x1	PLAIN WASHER 4.3X12X1	4
6	42122017	滑动胶带	SLIDE PROMOTING TAPE	4
7	4211213100	底板压板	PAVING PLATE GUIDE	2
8	421S10028	螺钉9/64-40X 2	SCREW 9/64-40X2	8
9	42112132	左衬布条	WORK PIECE CLAMP	1
10	421S17004	螺钉M4X25	SCREW M4X25	2
11	42112133	左衬布条气缸支架	WORK PIECE CLAMP CYLINDER BRACKET	1
12	S05067	螺钉M5x10	BOLT	2
13	42130052	气缸	AIR CYLINDER	1
14	41536009	节流阀	SPEED CONTROLLER	1
15	42102038	左衬布条驱动轴	WORK PIECE CYLINDER ROD	1
16	42112134	左衬布条气缸板	WORK PIECE CLAMP GUIDE PLATE	1
17	42122018	气缸螺母	WORK PIECE CYLINDER ROD BUSH	2
18	421S13017	螺钉M5x10	BOLT	2
19	40736036	Y型气管接头	QUICK COUPLING	1
20	61911001	气管	URETHANE HOSE BLACK	1
21	42137022	气管号标7	WIRE MARK (7)	11
22	42137002	绑扎带	CABLE BAND	6
23	42112135	三明治底板	PAVING PLATE	2
24	4211213600	中衬布条组件	HAIR CLOTH PRESSER	1
25	421S17002	螺钉M4X8	SCREW M4X8	2
26	40730095	气缸	AIR CYLINDER	1
27	S05119	螺钉M4x20	BOLT	2
28	N01001	螺母M4	NUT M4	2
29	42112137	中衬布气缸支架	HAIR CLOTH PRESSER CYLINDER BRACKET	1
30	421S13027	螺钉M5x12	BOLT	2
31	42136001	弯管接头	ELBOW UNION	1
32	42112138	缸盖	CYLINDER COVER	1
33	4211213900	滑动板8-14	SEWNING TABLE UNIT PAVING 8 -14	1
34	4211214000	滑动板16-20	SEWNING TABLE UNIT PAVING 16 -20	1



41、卷线装置/BOBBIN WINDER MECHANISM

序号 Ref.No.	公司件号 Part No.	名称	Description	数量 Amt.
1	1293100300	卷线器组合件	BOBBIN WINDER UNIT	1
2	H05012	挡圈E4	RETAINING RING E4	1
3	1290100500	卷线轴基座组件	B WINDER SHAFT SUPPORT ASSY	1
4	12902012	卷线轴基座组件	BOBBIN WINDER SHAFT	1
5	O01008	O形圈P9	O PRING P9	1
6	12928021	平垫圈S6	WASHER PLAIN S6	1
7	12935005	卷线轮	BOBBIN WINDER WHEEL	1
8	S09019	螺钉M5X5	SET SCREW SOCKER (FT) M5X5	2
9	12922014	橡皮垫圈29	RUBBER RING 29	1
10	1291000600	梭芯夹凸轮组件	BOBBIN PRESSER CAM ASSY	1
11	12910007	梭芯夹凸轮	BOBBIN PRESSER CAM	1
12	12902013	梭芯夹轴	BOBBIN WINDER ARM SHAFT	1
13	S09019	螺钉M5X5	SET SCREW SOCKER (FT) M5X5	1
14	H05012	挡圈E4	RETAINING RING E4	1
15	12928021	平垫圈S6	WASHER PLAIN S6	2
16	12904005	梭芯压臂柄	BOBBIN PRESSER ARM	1
17	S04040	螺钉M4X12	SCREW PAN M4X12	1
18	12912050	梭芯夹	BOBBIN PRESSER	1
19	129S11007	螺钉M4X5	SCREW M4X5	1
20	12911009	梭芯座	BOBBIN SUPPORT	1
21	12912051	卷线杠杆	BOBBIN WINDER LEVER	1
22	12927014	弹簧	SPRING	1
23	12927015	弹簧	BOBBIN WINDER BASE SPRING	1
24	12922015	O形密封圈	O RING SS5	1
25	129S11006	固定螺钉	BOBBIN WINDER TENSION ASSY	3
26	12919001	切刀	DISC TENSION	1
27	S04030	螺钉M5X6	SCREW M5X6	1
28	1291201100	卷线器夹线组件	TENSION NUT	1
29	12913007	夹线盘	WASHER	2
30	12927016	夹线弹簧	SET SCREW SOCKER (FT) M5X5	1
31	129S30013	压线螺母	SUPPORT TUBE	1
32	12928014	止动垫圈	CHECK WASHER	1
33	S09019	螺钉M5X5	SET SCREW SOCKER (FT) M5X5	1



**42、衬布压板组件/POCKET BAG CLAMP COMPONENTS**

序号 Ref.No.	公司件号 Part No.	名 称	Description	数量 Amt.
1	42112055	衬布压板	POCKET BAG CLAMP	1
2	421S10020	螺钉M4X5	SCREW M4X5	2
3	42128014	垫圈	WASHER	2
4	N01001	螺母M4	NUT M4	2

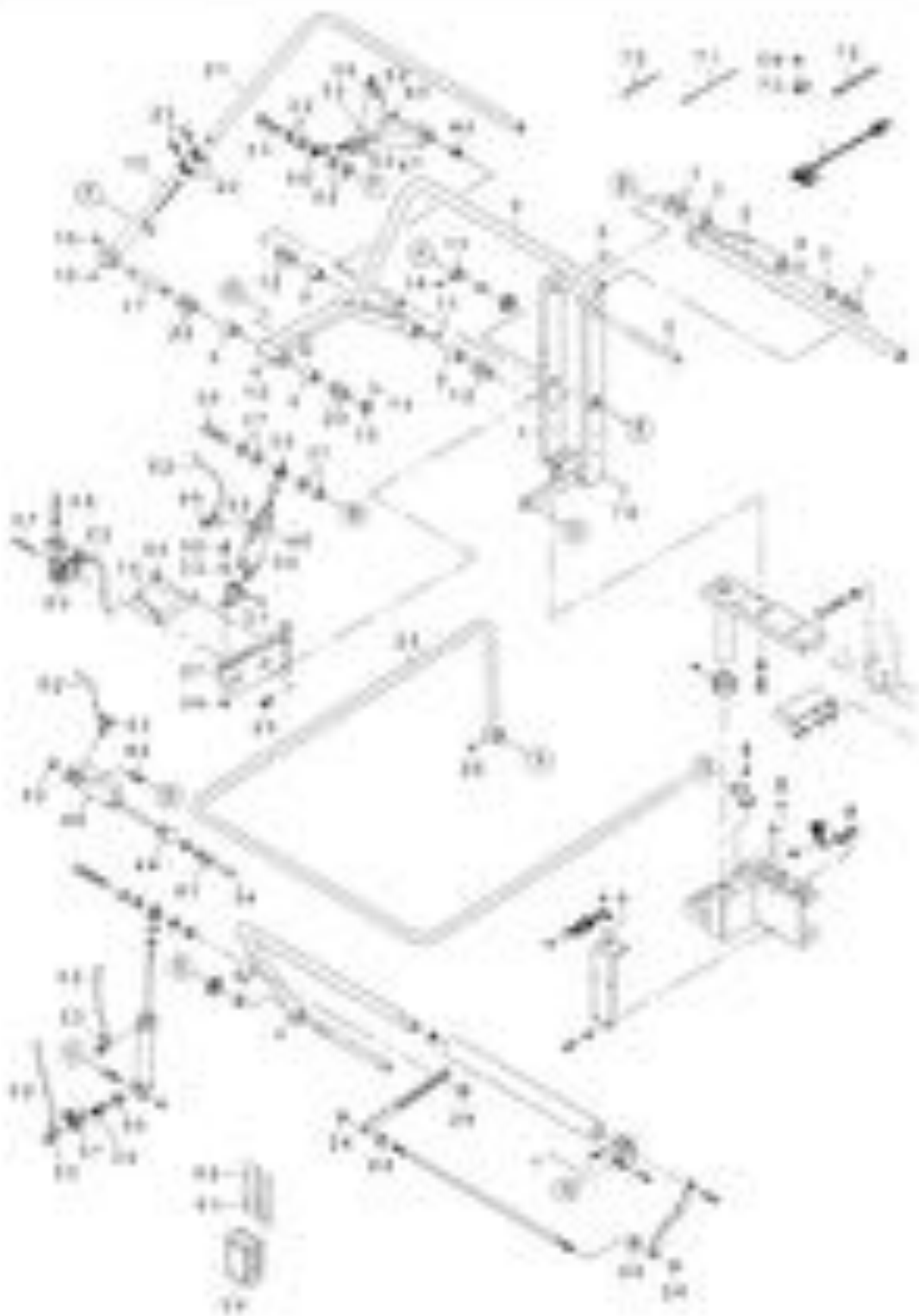



43、堆叠器组件(1) /CLAMP BAR STACKER DEVICE (1)

序号 Ref.No.	公司件号 Part No.	名称	Description	数量 Amt.
1	4213201100	堆叠器座	STACKER BASE E	1
2	4213201200	堆叠器压杆	CLOTH BRUSH BAR	1
3	42103014	铜套	METAL	2
4	S09008	螺钉M5X5	SCREW M5X5	2
5	42102043	轴	SHAFT B	1
6	S09009	螺钉M5X10	SCREW M5x10	2
7	42128011	垫圈	THRUST WASHER	4
8	4213201400	堆叠器布料杆	CLOTH BRUSH BAR	1
9	42103014	铜套	METAL	5
10	S09008	螺钉M5X5	SCREW M5X5	4
11	S09009	螺钉M5X10	SCREW M5x10	2
12	42128011	垫圈	THRUST WASHER	4
13	42108008	挡圈	THRUST COLLAR	1
14	421S14009	螺钉M6X6	SCREW M6X6	2
15	4213201500	摆杆支架	CLOTH BRUSH BAR	1
16	S09007	螺钉M6X8	SCREW M6X8	2
17	42102044	轴	SHAFT	1
18	42108008	挡圈	THRUST COLLAR	1
19	S09007	螺钉M6X8	SCREW M6X8	2
20	42128010	垫圈	THRUST WASHER	4
21	42132007	摆杆	CLOTH BRUSH BAR	1
22	42108012	固定圈	CLAMP	2
23	S05033	螺钉M6X12	BOLT	2
24	N01009	螺母M10	NUT M10	5
25	4213201600	保护杆	SAFTY BAR	1
26	S09007	螺钉M6X8	SCREW M6X8	2
27	42112179	电磁阀支架	VALVE BRACKET	1
28	421S13029	螺钉M6x12	SCREW	3
30	42130062	气缸	CYLINDER	1
31	4211218000	气缸转轴	CLEVIS HOLDER	1
32	S05028	螺钉M6x14	SCREW M6X14	2
33	W01003	垫圈	WASHER	2
34	N01007	螺母M6	NUT M6	2
35	40736020	鱼耳接头	ROD END	1
36	421S12007	螺钉M10X35	SCREW M10X35	1
37	42128050	垫圈10.5x21x2	WASHER 10.5X21X2	4
38	42130098	节流阀	SPEED CONTROLLER	2
39	42130089	磁开关	MAGNETIC SWITCH	2
40	42130063	气缸	AIR CYLINDER	1
41	42136021	Y型接头	CYLINDER JOINT	1
42	421S30024	气缸固定螺栓	CYLINDER SHAFT	1
43	H05013	卡簧6	E-RING 6	1
44	400751	活塞杆塞	CYLINDER ROD STOPPER	1
45	42130098	节流阀	SPEED CONTROLLER	2
46	42130090	固定夹	FIXED CLAMP	1
47	42130064	气缸	CYLINDER	1
48	421S30024	气缸固定螺栓	CYLINDER SHAFT	1
49	H05013	卡簧6	E-RING 6	1
50	40736025	鱼眼接头	ROD END	1

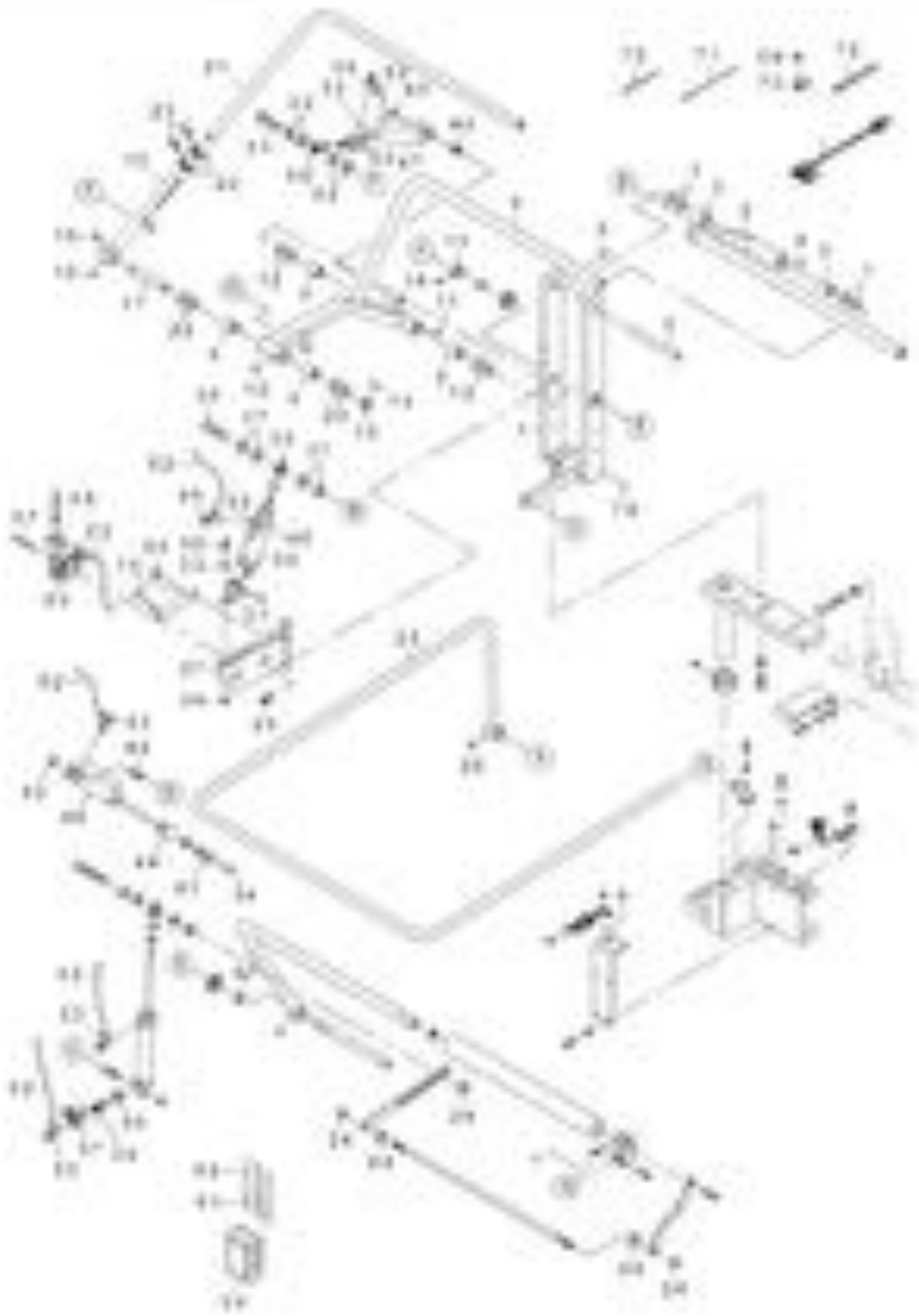

51	421S12008	螺钉	HEXAGONAL HEADED BOLT	1
52	W01010	垫圈M8	WASHER M8	4
53	42130098	节流阀	SPEED CONTROLLER	3
54	42126024	接头销	PIN	1
55	42130032	节流阀	SPEED CONTROLLER	1
56	42136022	接头	BUSHING	2
57	4073000900	调压阀	REGULATOR	1
58	42136023	通用接头	UNIVERSAL NIPPLE	1
59	40730043	脚踏板	ACTUATOR	1
61	40736045	弯管接头	HOSE ELBOW	3
62	61911001	气管	URETHANE HOSE BLACK	10
63	61911001	气管	URETHANE HOSE BLACK	1.5
64	421S11011	螺钉M4X8	SCREW M4X8	1
65	4213007600	电磁阀组件	MANIFOLD VALVE ASSY	1
66	421S13012	螺钉M4x10	SCREW	2
67	S05063	螺钉M4x25	SCREW M4X25	2
68	42130003	电磁阀电接头	AIR VALVE CABLE ASM	3
69	42130091	固定夹	FIXED CLAMP	1
70	42137002	绑扎带	CABLE BAND	10
71	42137013	绑扎带	CABLE BAND	10
72	61910028	螺旋管	SPIRAL TUBE	0.5
73	42137027	线夹	CABLE CLIP	1
74	42137005	商标标签	WEEE MARK LABEL	1
75	42112181	阀盖	VALVE COVER	1

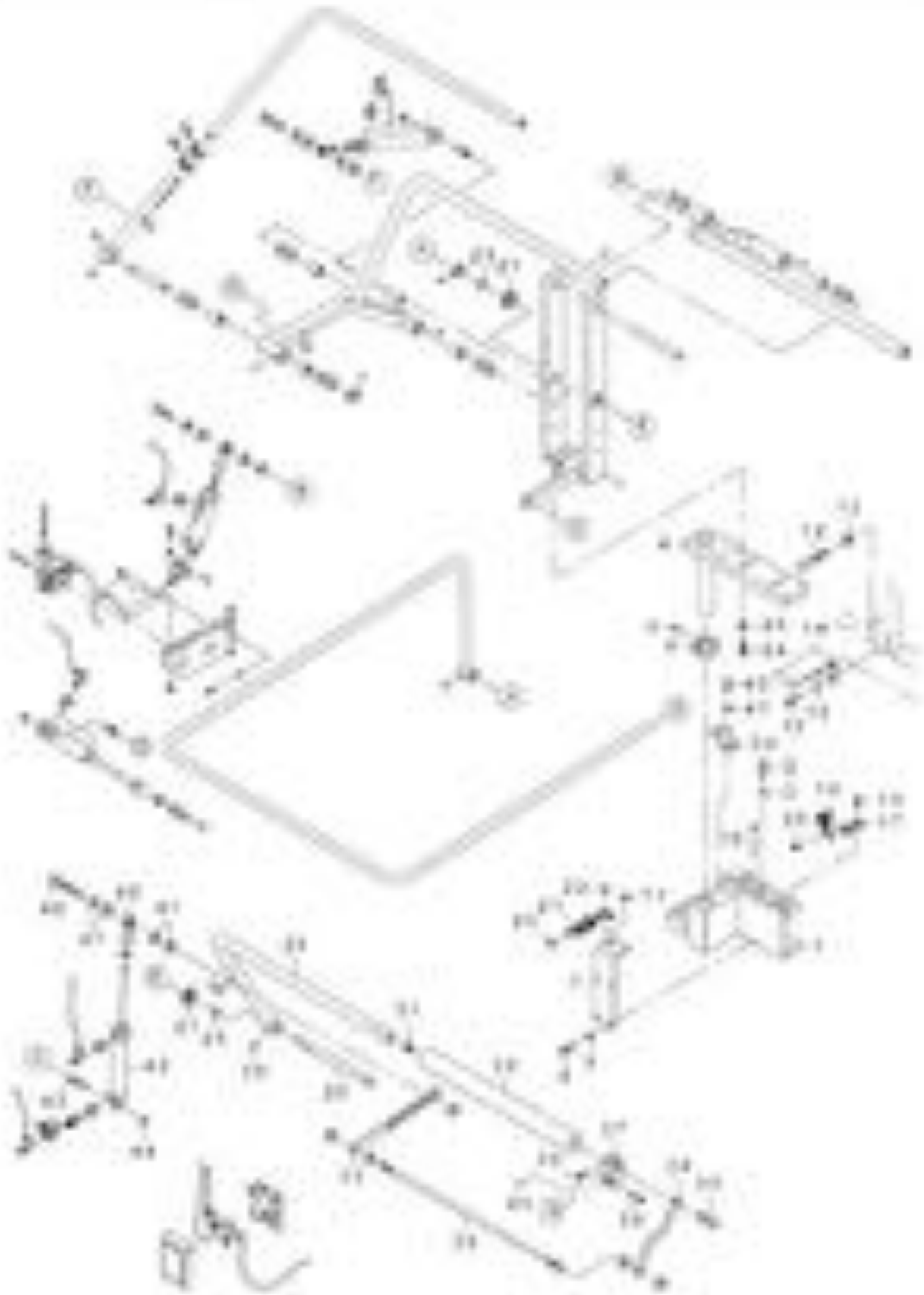

44、堆叠器组件(2) /CLAMP BAR STACKER DEVICE (2)

序号 Ref.No.	公司件号 Part No.	名称	Description	数量 Amt.
1	400956	堆叠器固定座	STACKER BASE	1
2	S05007	螺钉M8X20	SCREW M8X20	3
3	W01010	垫圈M8	WASHER M8	3
4	4213201700	转动支架	STACKER BASE	1
5	42108014	套	BASE COLLAR	1
6	S09001	螺钉M6X10	SCREW M6X10	2
7	42112182	固定铰链支架	STACKER BASE	1
8	S05040	螺钉M6X16	SCREW M6X16	4
9	W01003	垫圈	WASHER	4
10	42126018	定位销	BASE STAD	1
11	421S17009	螺钉M5X10	SCREW M5X10	1
12	421S12009	六角螺栓	HEXAGONAL BOLT	1
13	N01008	螺母M8	NUT M8	1
14	42112183	堆叠机支撑板	STACKER SUPPORT PLATE	1
15	421S13022	螺栓M8X16	BOLT M8X16	4
16	W01010	垫圈M8	WASHER M8	4
17	42112184	传感器安装架	SENSOR PLATE	1
18	421S13012	螺钉M4x10	SCREW	2
19	1143002300	安全开关组件	HEAD DETECT SWITCH ASM.	1
20	421S13012	螺钉M4x10	SCREW	1
21	42131006	固定铰链支架	ADJUSTABLE FASTENERS	1
22	421S17009	螺钉M5X10	SCREW M5X10	4
23	N01007	螺母M6	NUT M6	2
24	S05007	螺钉M8X20	SCREW M8X20	4
25	W01010	垫圈M8	WASHER M8	4
26	42102045	轴C	SHAFT C	1
27	B10018	滚动轴承	ROLLING BEARING	2
28	42128012	垫圈	WASHER	2
29	4210109300	堆叠器收料杆	CLAMP BASE	1
30	S09007	螺钉M6x8	SCREW M6X8	2
31	42112185	堆叠器橡皮塞	CLAMP BASE NUT	1
32	42102046	撑料杆	ASSIST BAR	1
33	42112186	连接件	ASSIST PLATE	1
34	42112187	连接件	ASSIST BAR SUPPORT PLATE	1
35	S05080	螺钉M10X20	SCREW M10X20	1
36	42122024	堆叠器收料杆护套	CLAMP BASE CUSHION	1
37	400954	支柱夹具	STRUT CLAMP	1
38	421S13072	螺钉	SCREW	4
39	42112188	堆叠器连接板	STACKER ROCK PLATE	1
40	S05028	螺钉M6x14	SCREW M6X14	4
41	W01003	垫圈	WASHER	4
42	42130063	气缸	AIR CYLINDER	1
43	421S30023	气缸固定螺栓	CYLINDER SHAFT	1
44	H05013	卡簧6	E-RING 6	1
45	40736020	鱼耳接头	ROD END	1
46	421S13073	螺栓M10X55	HEXAGONAL-HOLE BOLT M10X55	1
47	42128050	垫圈10.5x21x2	WASHER 10.5X21X2	4
48	42137001	警告标签	ATTENTION SEAL	1

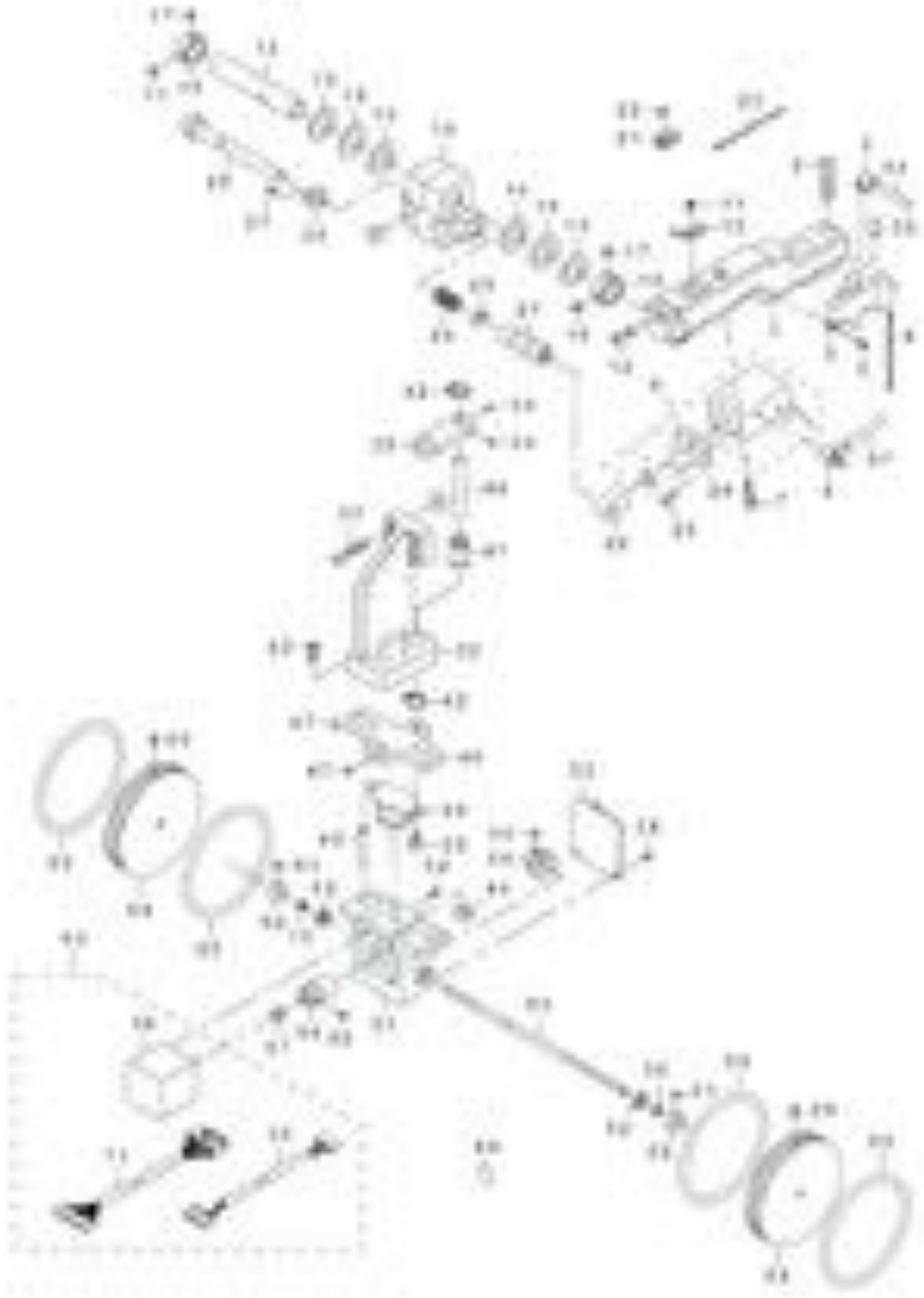

45、滚布轮装置/ROLLER STACKER DEVICESP



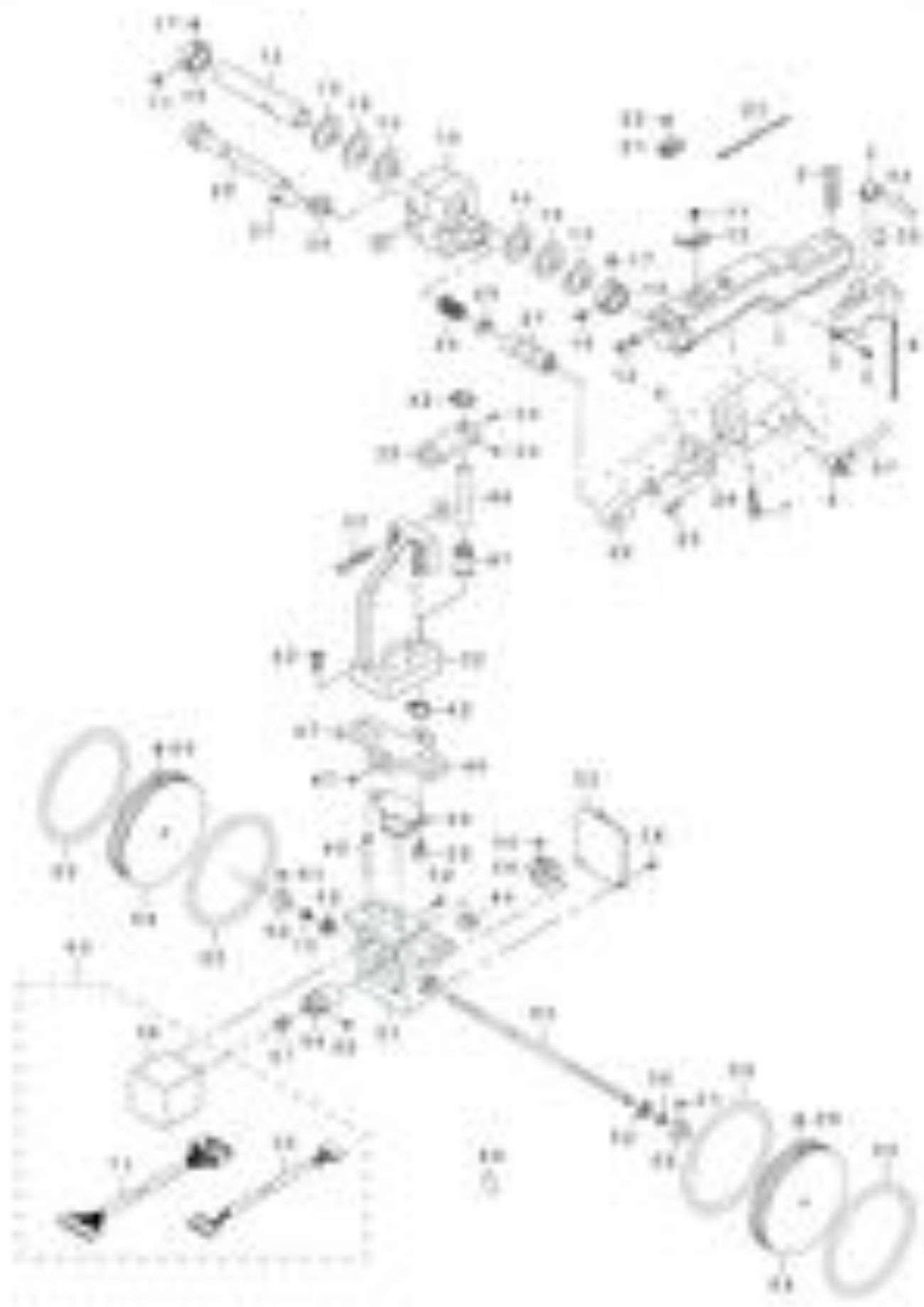

序号 Ref.No.	公司件号 Part No.	名称	Description	数量 Amt.
1	42101095	滚轮组件支撑架	ROLLER STACKER BASE	1
2	421S13057	螺钉 M8X30	SCREW M8X30	2
3	42130067	电磁阀	5-PORT SOLENOID VALVE	1
4	42130003	电磁阀电接头	AIR VALVE CABLE ASM.	1
5	S04076	螺钉 M3X8	SCREW M3X8.0	2
6	4213007400	滚布轮气缸组件	ASSY ROLLER STACKER CYLINDER	1
7	S05035	螺钉M5X25	HEXAGONAL-HOLE BOLT	2
8	42130032	节流阀	SPEED CONTROLLER	2
9	42136001	弯管接头	ELBOW	1
10	42112189	弹簧片	ROCK SPRING	1
11	421S10014	螺钉M4X6	SCREW M4X6	2
12	S05028	螺钉M6x14	SCREW M6X14	1
13	42102047	空心轴	PIVOT SHAFT	1
14	42101096	支架	PIVOT BASE	1
15	42108015	挡圈	THRUST COLLAR	2
16	S12001	螺钉 M6X8	SCREW M6X8	1
17	421S14009	螺钉M6X6	SCREW M6X6	3
18	42124022	轴承	THRUST BEARING	2
19	42128013	垫圈	THRUST WASHER	4
20	42102048	轴	ROCK SHAFT	1
21	42137018	线夹	CABLE CLIP	3
22	421S10014	螺钉M4X6	SCREW M4X6	3
23	42137002	绑扎带	CABLE BAND	5
24	42112190	气缸挡板	CYL PLATE	1
25	S05067	螺钉M5x10	BOLT	2
26	400957	气缸连接头	CYL JOINT	1
27	42103016	铜套	METAL	1
28	42127012	弹簧	SPRING	1
29	H05009	卡簧7	E-RING 7	1
30	42112191	弹簧挡板	SPRING PLATE	1
31	421S10033	螺钉 M3X8	SCREW M3X8	2
32	400958	滚轮支撑架	ROLLER STACKER ARM	1
33	42130070	连接线缆	ROLLER STACKER RERAY CORD D ASM	1
34	42133005	步进电机	ROLLER STACKER MOTOR	1
35	42128001	消声器	SILENCER	2
36	42128052	垫圈6.2x9.5x1	WASHER 6.2X9.5X1	2
37	S05031	螺钉M6X20	SCREW M6X20	4
38	400959	支架	SHAFT GUIDE BLOCK	1
39	421S14005	螺钉M4X6	SCREW M4X6	4
40	42102049	轴	GUIDE SHAFT	2
41	42124023	轴承	BEARING	2
42	H03001	卡簧13.8	RETAINING RING 13.8	4
43	421S12003	限位螺钉M5x16	STOPPER BOLT	1
44	42137005	商标标签	WEEE MARK LABEL	1
45	42102050	轴	GUIDE SHAFT	2
46	400960	底板	BASE PLATE	1
47	421S14005	螺钉 M4X6	SCREW M4X6	4
48	42110004	减震器	DAMPER	1
49	N01008	螺母M8	NUT M8	1











50	S05070	螺钉M6X10	SCREW M6X10	2
51	400961	齿轮箱	GEAR BOX	1
52	S05094	螺钉M3X8	SCREW M3X8	4
53	42112195	盖板	GEAR BOX COVER	1
54	421S10027	螺钉M3X6	SCREW M3X6	3
55	421S14001	螺钉M5x6	SCREW M5X6	2
56	42108016	联轴器	WORM	1
57	42124010	推力轴承	THRUST BEARING	1
58	42125004	齿轮	WORM WHEEL	1
59	421S14001	螺钉M5x6	SCREW M5X6	2
60	42108017	挡圈	LINK THRUST HOLDER	2
61	421S14005	螺钉 M4X6	SCREW M4X6	4
62	42124024	轴承	BALL BEARING	2
63	42102051	滚轮支撑轴	ROLLER SHAFT	1
64	400962	滚轮	ROLLER 90	2
65	42122028	O型圈	O RING	4
66	S09015	螺钉M4X10	SCREW M4X10	2
67	61911001	气管	URETHANE HOSE BLACK	0.5
68	61911001	气管	URETHANE HOSE BLACK	0.3
69	4213007500	滚轮电机组件	ROLLER STACKER CTL	1
70	42130069	连接线缆	ROLLER STACKER RERAY CORD ASM	1

MS. GROUP P. N.	MS. GROUP P. N.	MS. GROUP P. N.	MS. GROUP P. N.
			
100	100	100	100
100	100	100	100
100	100	100	100
100	100	100	100
100	100	100	100
100	100	100	100
100	100	100	100
100	100	100	100

MS. GROUP P. N.	MS. GROUP P. N.	MS. GROUP P. N.	MS. GROUP P. N.
			
100	100	100	100
100	100	100	100
100	100	100	100
100	100	100	100
100	100	100	100
100	100	100	100
100	100	100	100

MODEL NUMBER P/N	DESCRIPTION P/N	DESCRIPTION P/N	DESCRIPTION P/N
			
1994-02-01	1994-02-01	1994-02-01	1994-02-01
1994-02-01	1994-02-01	1994-02-01	1994-02-01
1994-02-01	1994-02-01	1994-02-01	1994-02-01
1994-02-01	1994-02-01	1994-02-01	1994-02-01
1994-02-01	1994-02-01	1994-02-01	1994-02-01
1994-02-01	1994-02-01	1994-02-01	1994-02-01
1994-02-01	1994-02-01	1994-02-01	1994-02-01
1994-02-01	1994-02-01	1994-02-01	1994-02-01
1994-02-01	1994-02-01	1994-02-01	1994-02-01

MODEL NUMBER P/N	DESCRIPTION P/N
	
1994-02-01	1994-02-01
1994-02-01	1994-02-01
1994-02-01	1994-02-01
1994-02-01	1994-02-01
1994-02-01	1994-02-01
1994-02-01	1994-02-01
1994-02-01	1994-02-01
1994-02-01	1994-02-01
1994-02-01	1994-02-01

MODEL NUMBER P/N	DESCRIPTION P/N
	
1994-02-01	1994-02-01
1994-02-01	1994-02-01
1994-02-01	1994-02-01
1994-02-01	1994-02-01
1994-02-01	1994-02-01
1994-02-01	1994-02-01
1994-02-01	1994-02-01
1994-02-01	1994-02-01
1994-02-01	1994-02-01

Model number H 10	Graph with grid graph H 1000B				
					
H 100	1	H 1000B	1.0	1.0	10.0
H 1000	2	H 1000B	2.0	2.0	10.0
	4	H 1000B	4.0	4.0	10.0
H 10000	8	H 1000B	8.0	8.0	10.0
	16	H 1000B	16.0	16.0	10.0
H 100000	4	H 1000B	4.0	4.0	10.0
H 1000000	1	H 1000B	1.0	1.0	10.0
H 10000000	4	H 1000B	4.0	4.0	10.0
H 100000000	4	H 1000B	4.0	4.0	10.0

Model number H 10	Graph with grid graph H 1000B				
					
H 100	1	H 1000B	1.0	1.0	10.0
H 1000	2	H 1000B	2.0	2.0	10.0
H 10000	4	H 1000B	4.0	4.0	10.0
H 100000	8	H 1000B	8.0	8.0	10.0
H 1000000	16	H 1000B	16.0	16.0	10.0
H 10000000	32	H 1000B	32.0	32.0	10.0
H 100000000	64	H 1000B	64.0	64.0	10.0

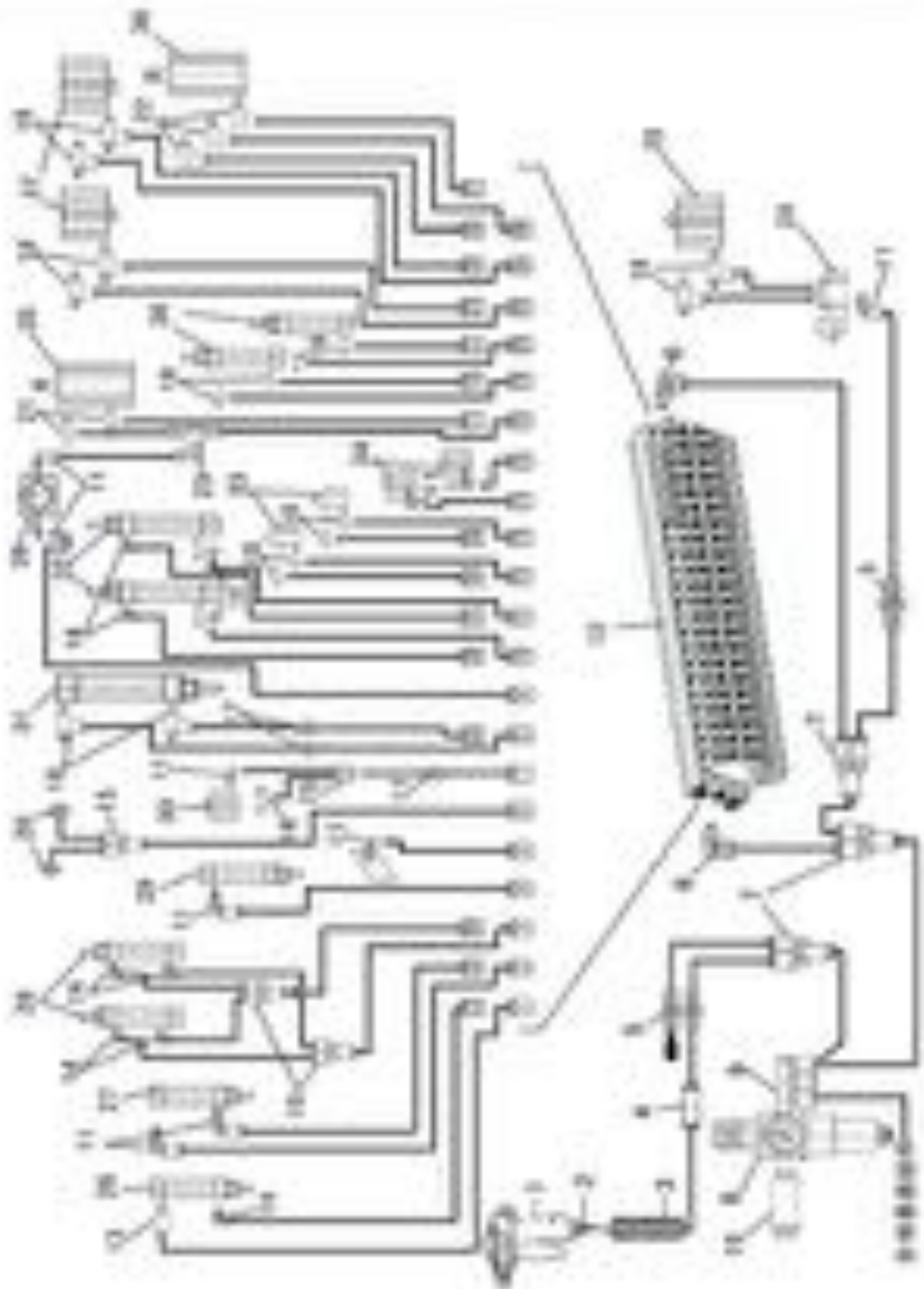

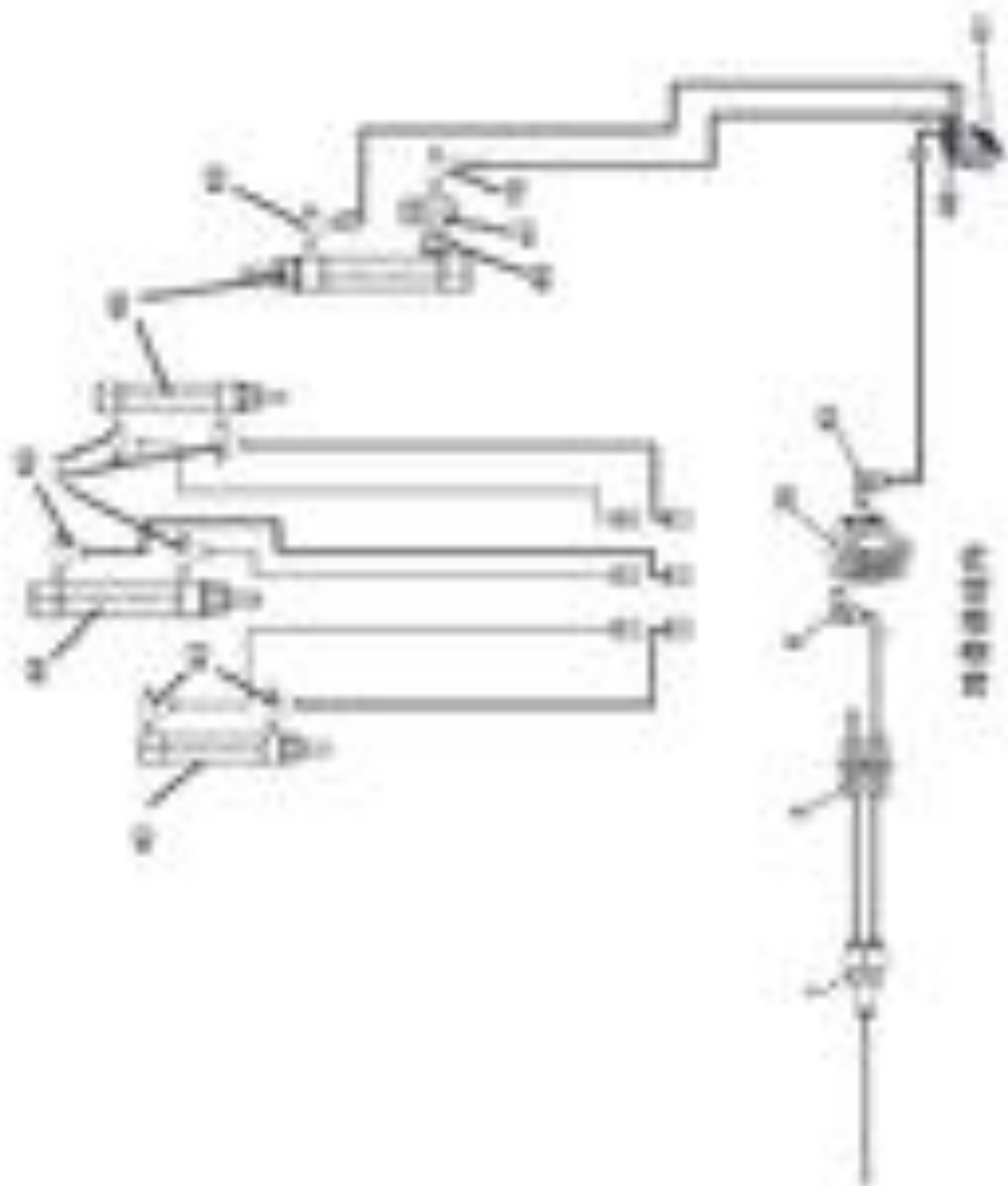

49、气动回路图/PNEUMATIC CIRCUIT DIAGRAM

序号 Ref.No.	公司件号 Part No.	名称	Description	数量 Amt.
1	42130102	气枪	AIR GUN	1
2	40736018	气管接头	HALF UNION 6XPT1/4	1
3	40130103	螺旋管	COIL TUBE	1
4	42136024	气管接头	STRAIGHT UNION	1
5	42136016	带螺纹气管接头6	UNION	5
6	42136019	弯管接头	ELBOW UNION	3
7	40736015	Y接头	Y UNION	4
8	4213008800	过滤器	FILTER	1
9	42136018	六分插头	TRIPLE BRANCH UNIVERSAL ELBOW	1
10	42130096	滑动阀	SLIDE VALUE	1
11	42136001	弯型接头	ELBOW UNION	10
12	4213009400	电磁阀组件	MANIFOLD VALVE ASSY	1
13	40736048	接头	BUSHING	1
14	42136007	弯管接头	HOSE ELBOW	7
15	40736036	Y接头	Y UNION	4
16	41536009	节流阀	SPEED CONTROLLER	1
17	42136014	带螺纹气管接头4	UNION	3
18	42130032	节流阀	SPEED CONTROLLER	17
19	42130038	节流阀	SPEED CONTROLLER	2
20	42136010	气管接头	CONNECTOR	2
21	42130050	节流阀	SPEED CONTROLLER	2
22	42136004	弯型接头	ELBOW UNION	3
23	42130087	梭阀	SHUTTLE VALVE	1
24	40730082	电磁阀	MAGNETIC VALVE	1
25	4213007400	气缸	AIR CYLINDER	1
26	42130008	气缸	AIR CYLINDER	1
27	42130001	气缸	AIR CYLINDER	1
28	42130007	气缸	AIR CYLINDER	2
29	42130005	气缸	AIR CYLINDER	1
30	40730095	气缸	AIR CYLINDER	1
31	42130051	气缸	AIR CYLINDER	1
32	42130037	气缸	AIR CYLINDER	2
33	42130031	气缸	AIR CYLINDER	2
34	42130029	气缸	AIR CYLINDER	2
35	40130049	气缸	AIR CYLINDER	1
36	42130033	气缸	AIR CYLINDER	2
37	42130035	气缸	AIR CYLINDER	2
38	42130004	气缸	AIR CYLINDER	1
39	4013007600	电磁阀组件	MANIFOLD VALVE ASSY	1
40	42136025	接头	BUSHING	
41	40730043	脚踏板	ACYUATOR	1
42	42130064	气缸	AIR CYLINDER	1
43	42130098	节流阀	SPEED CONTROLLER	7
44	42130062	气缸	AIR CYLINDER	1
45	42130063	气缸	AIR CYLINDER	2
46	42136023	通用接头	UNIVERSAL NIPPLE	1
47	4073000900	调压阀	REGULATOR	1
48	40736045	弯管接头	HOSE ELBOW	3

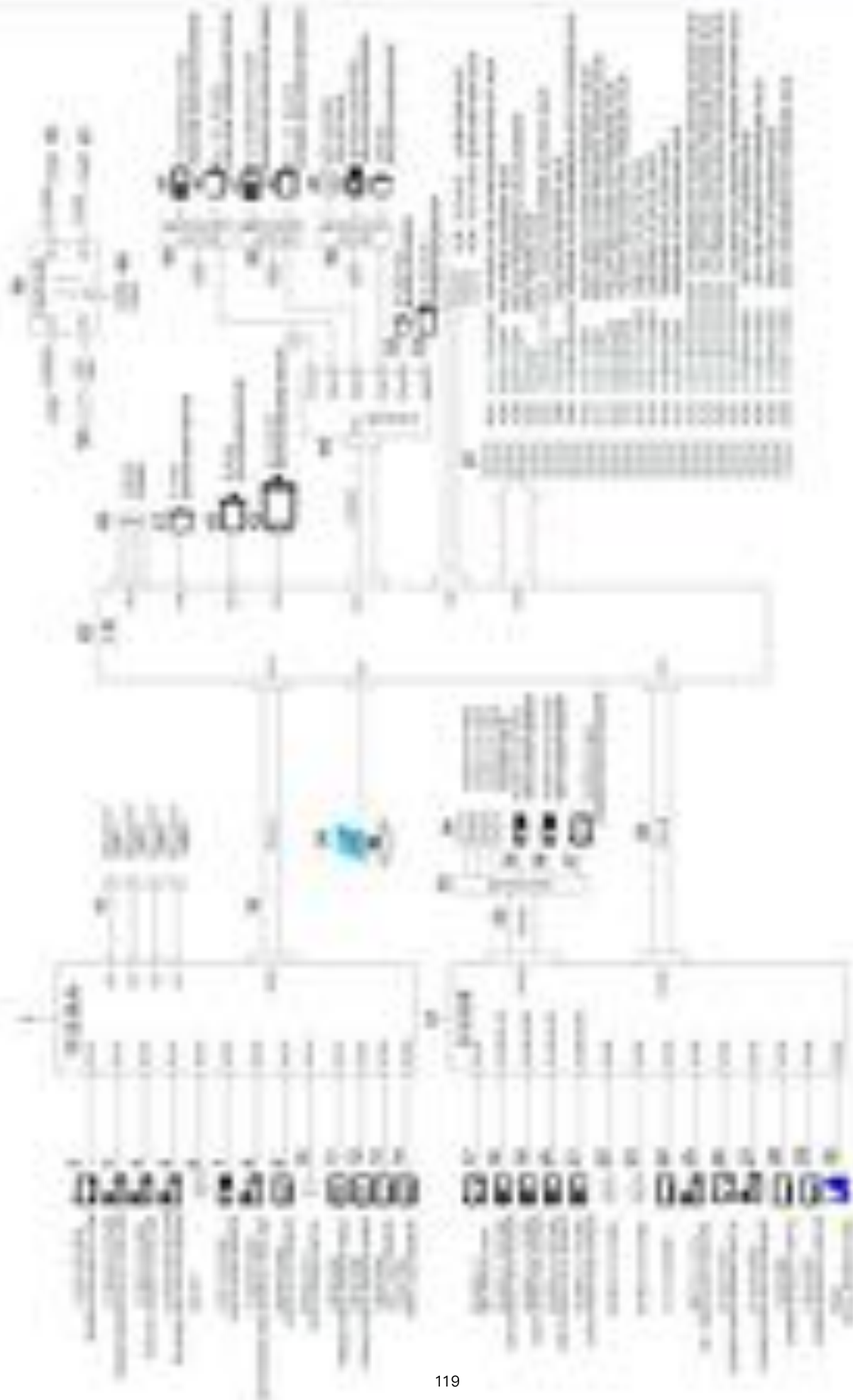



50、接线图/WIRING DIAGRAM

序号 Ref.No.	公司件号 Part No.	名称	Description	数量 Amt.
1	60900024	电路转接板A	INT PCB ASSY	1
2	61801002	中压板开闭传感器	BINDER OPEN SWITCH ASM	1
3	40330010	中压板抬起位置传感器	BINDER SENSOR RELAY CORD ASM	1
4	40330010	大压脚后定位传感器	STEP OUT SENSOR CORD ASM	1
5	40330010	针杆摆动电机位置传感器	REVERSE FEED MOTOR SENSOR	1
6	61905004	5558-14P接插件	CONNECTOR 5558-14P	1
7	42130089	中顶杆位置传感器	AIRCYLINDER SENSOR	1
8	40330010	大压脚异常传感器	BIG PRESSER ORG SENSOR CORD ASM	1
9	4213007300	测布传感器	CHECK CLOTH SENSOR	1
10	4213001800	紧急停车开关	STOP RUNNING SWITCH	1
11	42130012	左断线传感器	THREAD CHECK SENSOR ASM(L)	1
12	42130012	右断线传感器	THREAD CHECK SENSOR ASM(R)	1
13	42130025	左袋盖传感器	LEFT FLAP SENSOR	1
14	42130025	右袋盖传感器	RIGHT FLAP SENSOR	1
15	42130104	激光灯	LAMP	4
16	62800013	转接线	TRANSIT LINE	2.9m
17	40730002	膝动踏板开关	NEE SWITCH ASSY	1
18	42130089	移动侧角刀下降传感器（直袋用）	AIRCYLINDER SENSOR(FOR 5878-68B)	1
	42130040	移动侧角刀下降传感器（斜袋用）	AIRCYLINDER SENSOR(FOR 5878-78)	1
19	42130089	移动侧角刀上升传感器（直袋用）	AIRCYLINDER SENSOR(FOR 5878-68B)	1
	42130040	移动侧角刀上升传感器（斜袋用）	AIRCYLINDER SENSOR(FOR 5878-78)	1
20	42130089	固定侧角刀下降传感器（直袋用）	AIRCYLINDER SENSOR(FOR 5878-68B)	1
	42130040	固定侧角刀下降传感器（斜袋用）	AIRCYLINDER SENSOR(FOR 5878-78)	1
21	42130089	固定侧角刀上升传感器（直袋用）	AIRCYLINDER SENSOR(FOR 5878-68B)	1
	42130040	固定侧角刀上升传感器（斜袋用）	AIRCYLINDER SENSOR(FOR 5878-78)	1
22	61905016	5557-8A接插件	CONNECTOR 5557-8A	1
23	61905019	5557-10A接插件	CONNECTOR 5557-10A	1
24	4213008800	空气压力传感器	AIR PRESSURE SENSOR	1
25	40330010	针杆位置传感器	NEEDLE BAR POSITION SENSOR	1
26	61801002	角刀架打开闭合传感器	CORNER KNIFE DRAWER SWITCH SENSOR	1
27	40330010	角刀归位传感器	CORNER KNIFE MOTOR SENSOR	1
28	42130025	左底线传感器	BOBBIN SENSOR N ASSY(L)	1
29	42130025	右底线传感器	BOBBIN SENSOR N ASSY(R)	1
30	807286	脚踏板	PEDAL SENSOR B ASM.	1
31	60900024	电路转接板B	INT PCB ASSY	1
32	62800018	转接线	TRANSIT LINE	2.1m
33	61905005	5557-14P接插件	CONNECTOR 5557-14P	1
34	40730082	堆叠器电磁阀	STACKER VALVE	3
35	42130089	堆叠器压杆位置传感器	AIRCYLINDER SENSOR	1
36	42130089	堆叠器打布杆位置传感器	AIRCYLINDER SENSOR	1
37	61801002	堆叠器归位传感器	STACKER POSITION SENSOR	1
38	62800013	转接线	TRANSIT LINE	2.9m
39	4213008500	液晶屏	PANEL	1
40	61301014	主板电源	POWER	1
41	42133001	中刀电机	CENTER KNIFE MOTOR	1
42	42133004	拖布电机	BIG PRESSER MOTOR	1
43	42133007	机头主轴电机	SEWING MACHINE MOTOR	1
44	42133011	步进电机驱动板	STEP MOTOR CONTROL BOARD	1
45	42130040	角刀固定侧电机原点传感器	FIXED SIDE INDEX MOTOR SENSOR CORD ASM	1

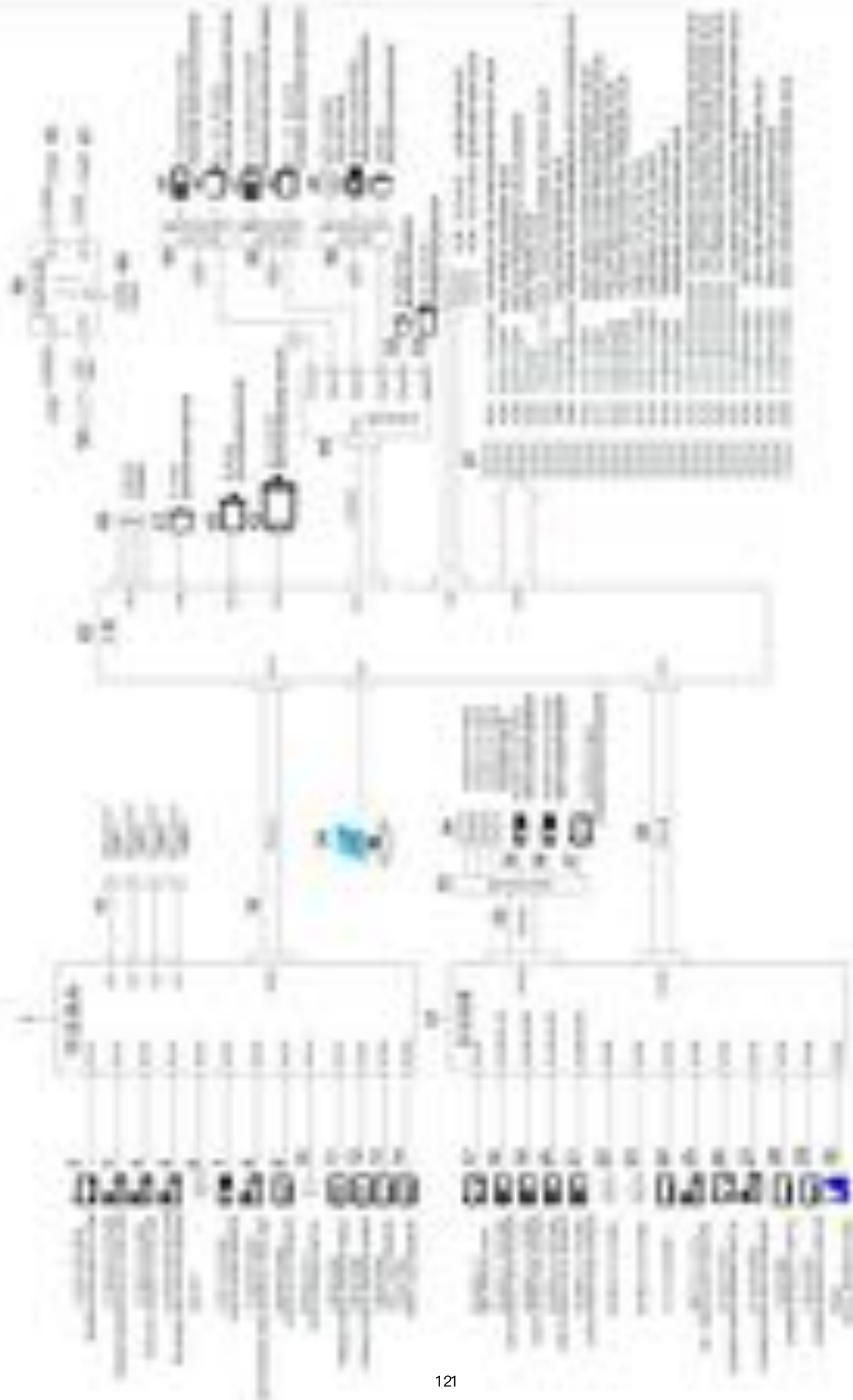

46	42133005	X轴角刀固定侧电机	FIXED SIDE CORNER KNIFE MOTOR	1
47	42130040	角刀移动侧电机原点传感器	MOVEMENT SIDE INDEX MOTOR SENSOR CORD ASM	1
48	42133005	X轴角刀移动侧电机	MOVEMENT SIDE CORNER KNIFE MOTOR	1
49	40730082	滚轮升降电磁阀	ROLLER VALVE	1
50	42130097	滚轮抬起位置检测传感器	ROLLER POSITION SENSOR	1
51	42133005	滚轮电机	ROLLER STACKER MOTOR	1
52	42133002	针杆摆动电机	REVERSE FEED MOTOR	1
53	42133006	Y轴角刀移动电机	CORNER KNIFE MOTOR	1
54	61905020	5557-10Y接插件	CONNECTOR 555Y-10Y	1
55	61905003	5557-8Y接插件	CONNECTOR 5557-8Y	1
56	61905005	5557-14P接插件	CONNECTOR 5557-14P	1
57	40730082	电磁阀	AIR SOLENOID VALVE	25
58	60900025	电源转接板	PCB	1
59	61600006	散热扇	FAN COOLER	1
60	40733008	机头主轴电机驱动器	SEWING MACHINE MOTOR DRIVER	1
61	42133009	拖布电机驱动器	BIG PRESSER MOTOR DRIVER	1
62	61900019	主控制电路板	MAIN CONTROL BOARD	1